

HYDRA 3 2006

02.03.2006

I Hydra 1 blev Hydra anskuet som en dynamisk topologi af kræfter, forløb, flows af naturfænomener, stedets topografi og geologi, bosætningsmønstre, naturkræfter, turisme etc. Hydra blev set som et labilt landskab, hvor kontinuerte forløb af kræfter strømme og hvirvler danner graduerede udvekslinger, bratte overgange, lokale fortætninger, rifter der op- og sammenskærer flows.

STEDER - FORTÆTNINGER - KOMPONENTER/INDSÆTTELSER

I Hydra 2 blev blikket vendt fra den landskabelige kortlægning af kræfter til den vertikale sammenskæring af *begivenheder* gennem udvekslinger og fortætninger. En bevægelse fra kortets planfigur til snittets dybde. **Komponenten**, der er en *begivenhed* (ved at udgøre et kunstnerisk udsagn) kan anskues som et udgangspunkt for sådan en overvejelse. Den kan opfattes som en figur, der gennemstrømmes af en række kræfter med forskellig intensitet.

I komponenter findes de forbindelser, udvekslinger, fortætninger, der skaber hvirvler i det flydende og binder materialet i forskellige konfigurationer. Hver udveksling udtrykker et udstrakt felt: med mange rumligheder, i elastiske udstrækninger og hver med flere mulige betydningsbærende positioner.

KOMPONENTEN – DET PLASTISKE MODUL

I Hydra 3 tages afsæt i det "plastiske", hvor den udfoldede komponent beskriver de formmæssige egenskaber og de "funktionelle" egenskaber i relation til topografien og hvor der foretages en genforhandling omkring *sammensyningen* i en kartografisk beskrivelse.

I de tegningsmæssige kompositioner er der arbejdet med en dybde, en ombyttelighed mellem figur og grund og med en anelsesfuld dybde som et *melletrum* i figurene. Her udgør tegningerne et kompositionsplan gennem deres konnotationer i flertydige og ombyttelige relationer.

Hvorledes kan denne erfaring udfoldes og bindes yderligere op i

KONSTRUKTIONER – moduleringer og artikuleringer.

Ved konstruktioner forstås *det sammenføjede* og *de skabte enheder*, der har en bestemt funktionalitet indenfor en bestemt diskurs.

Moduleringerne kan ses som *det tilpassede* – det der formidler, eller *det utilpassede* – det der åbner og/eller favner; en modulering kan således indskrives i eller rumme både *et aftryk* og samtidig *en gestus*.

Artikuleringer kan ses som fremhævelser, understregninger, skift i glidninger, bevægelser, - der annoncerer potentialer, karakterer, muligheder, etc.

Det plastiske modul udviser konstruktive elementer: sammenføjede dele og konstruktionslignende relationer: stativ, genstand, forbindelser, etc. (og tegningsmæssige konstruktioner), der indskrives i en gensidig afhængighed og med skiftende markeringer i bestemte konfigurationer.

Denne afhængighed – dette mellemrum – udgør et ikke synligt *konstrukt*, der viser sig som en konstruktion.

Det er mellem det *ikke synlige og synlige*, vi i første omgang opererer i udformningen af *konstruktionerne*.

Ordet *konstruktion* rummer umiddelbart *en forestilling af gensidige afhængige dele i et statisk forhold* og relaterer sig til begrebet: *kræfter*.

Konstruktioner kunne således tænkes som et kraftfelt, en passage for kræfter, en tilblivelse gennem udveksling mellem kræfter.

2. marts 2006:

Gruppe 1. Hans, Maj, Maria F. Stig

Mellem markeringerne **1 og 2** udfoldes en række moduleringer der udveksler faste og flydende tilstande.

Det *faste* kan være særlige markeringer i det topografiske, dominerende tilstande i det morfologiske eller "valgte indsættelser", der udgør *en skabt forankring*.

Det *flydende* kan være særlige bevægelser og kræfter der gennemstrømmer det topografiske og det morfologiske og "skaber glidninger", der udgør *en smidig sammenvævning*.

Gruppe 2. Flemming, Signe, Emelie, Kristine

Mellem markeringerne **2 og 3** udfoldes en række moduleringer der udveksler faste og flydende tilstande.

Det *faste* kan være særlige markeringer i det topografiske, dominerende tilstande i det morfologiske eller "valgte indsættelser", der udgør *en skabt forankring*.

Det *flydende* kan være særlige bevægelser og kræfter der gennemstrømmer det topografiske og det morfologiske og "skaber glidninger", der udgør *en smidig sammenvævning*.

Gruppe 3. Sidse, Maria W. Jesper, Lizette

Mellem markeringerne **3 og 1** udfoldes en række moduleringer der udveksler faste og flydende tilstande.

Det *faste* kan være særlige markeringer i det topografiske, dominerende tilstande i det morfologiske eller "valgte indsættelser", der udgør *en skabt forankring*.

Det *flydende* kan være særlige bevægelser og kræfter der gennemstrømmer det topografiske og det morfologiske og "skaber glidninger", der udgør *en smidig sammenvævning*.

Udgangspunkter for moduleringer

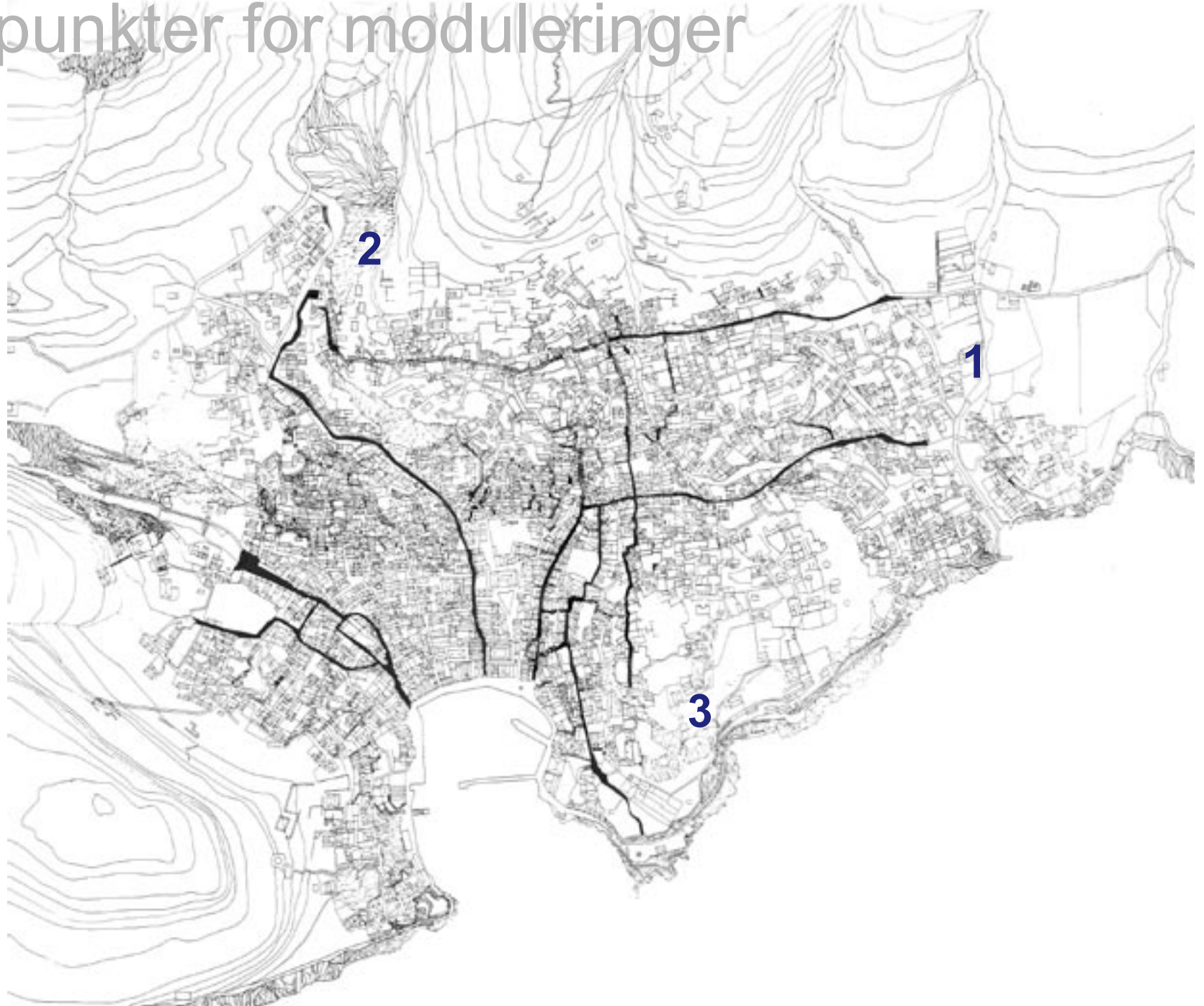

transformerende_ _registrende

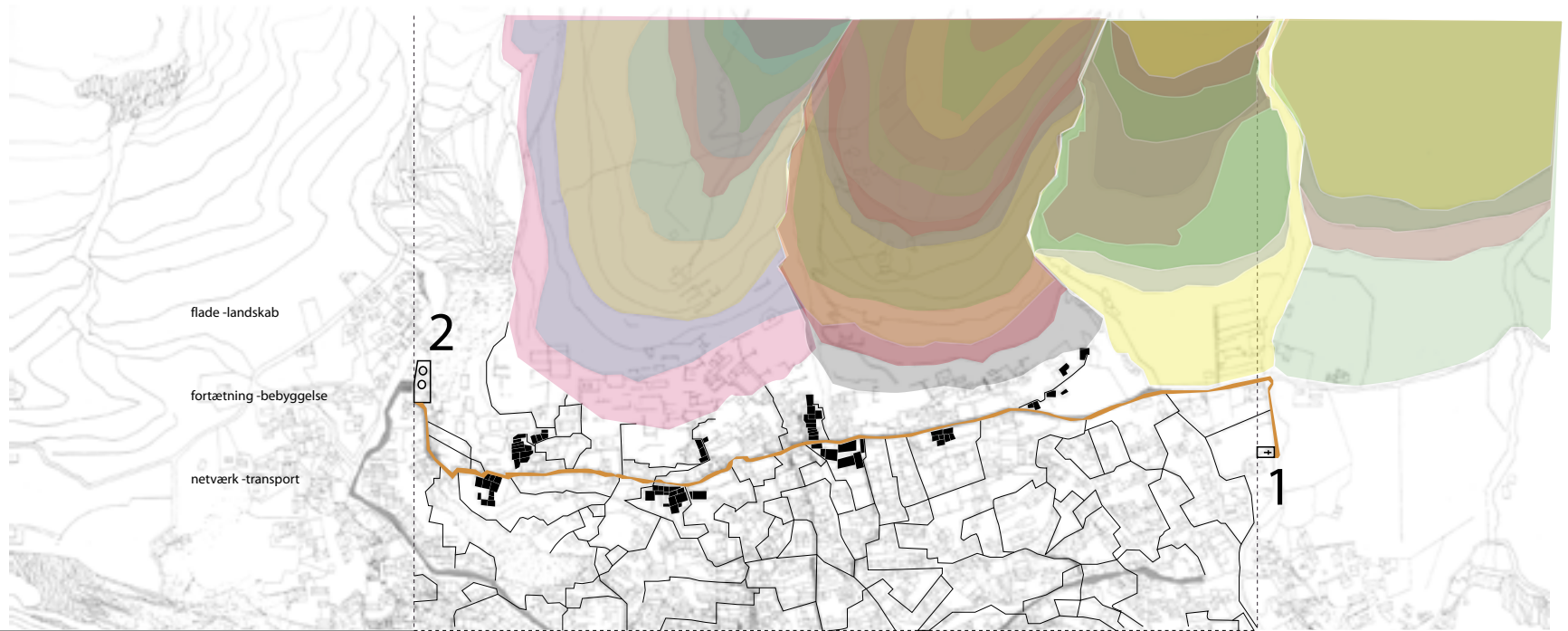

4 skabte enheder med hver sin funktionalitet
-der undersøger en sammenføjning af de 4 elementer, som hver sin del af et maskineri med hver sin kraft

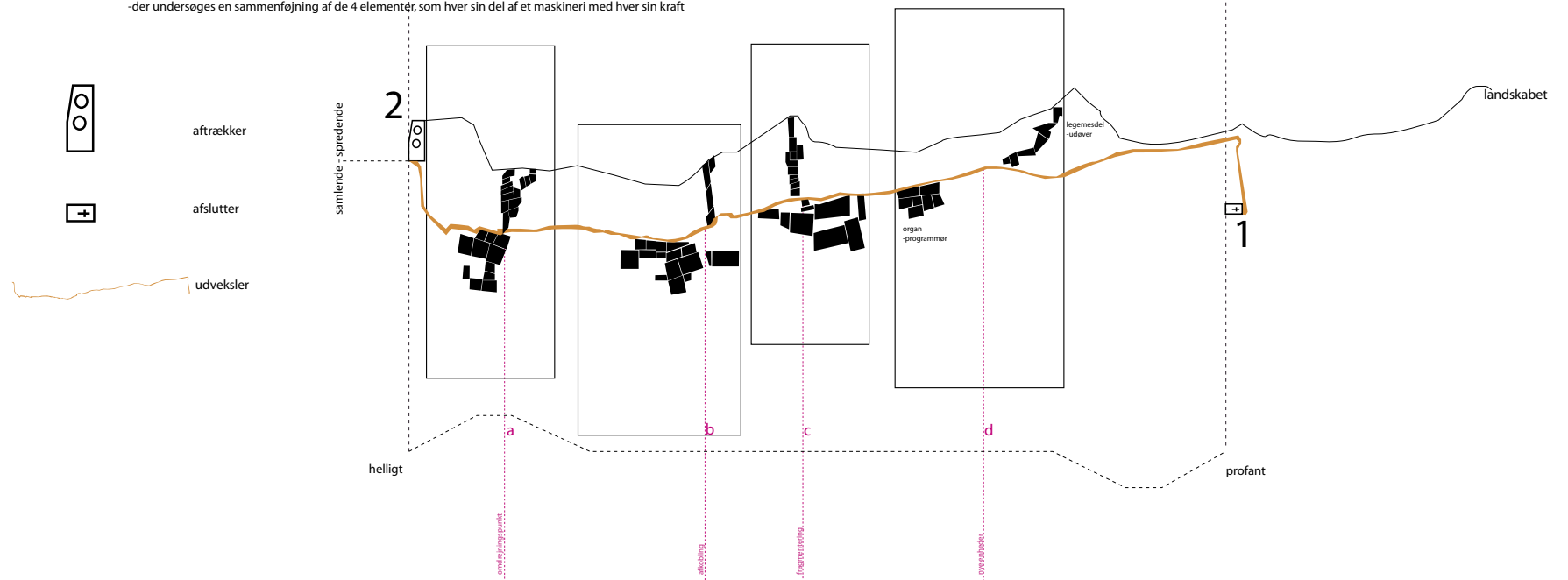

4 skabte enheder med hver sin funktion
-der undersøges en sammenføring af de 4 elementer, som hver sin del af et maskineri med hver sin kraft

transformerende_

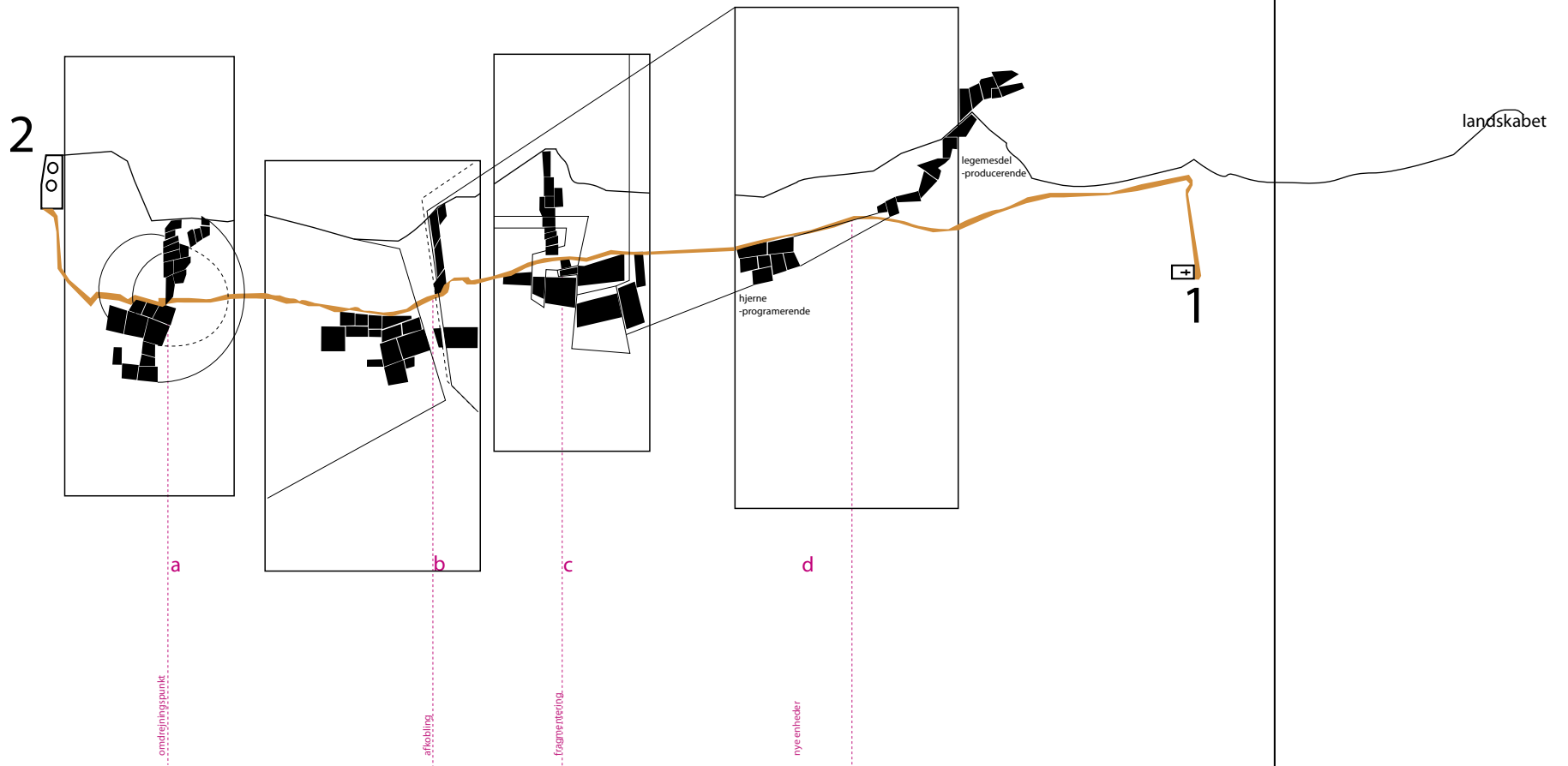

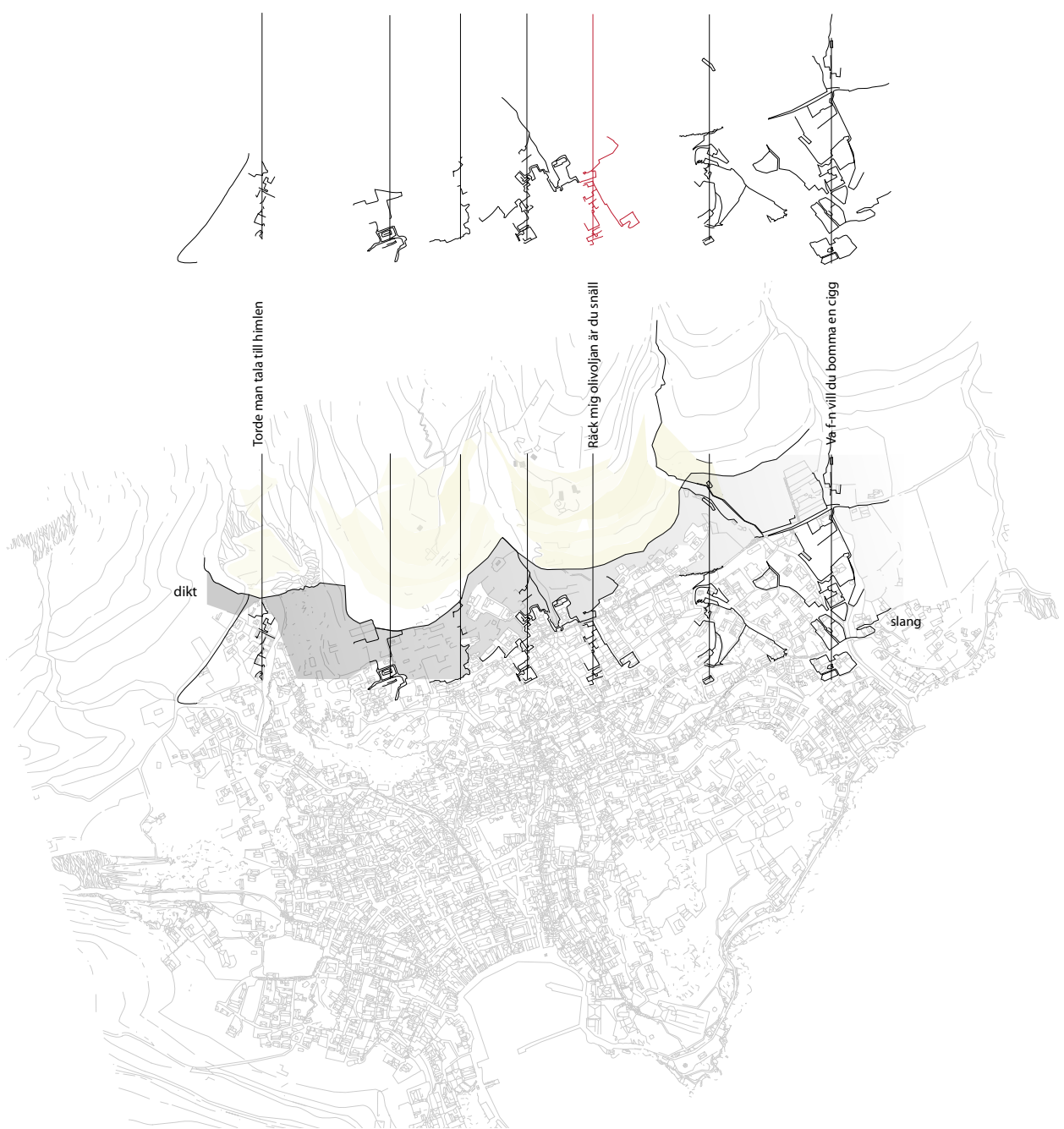

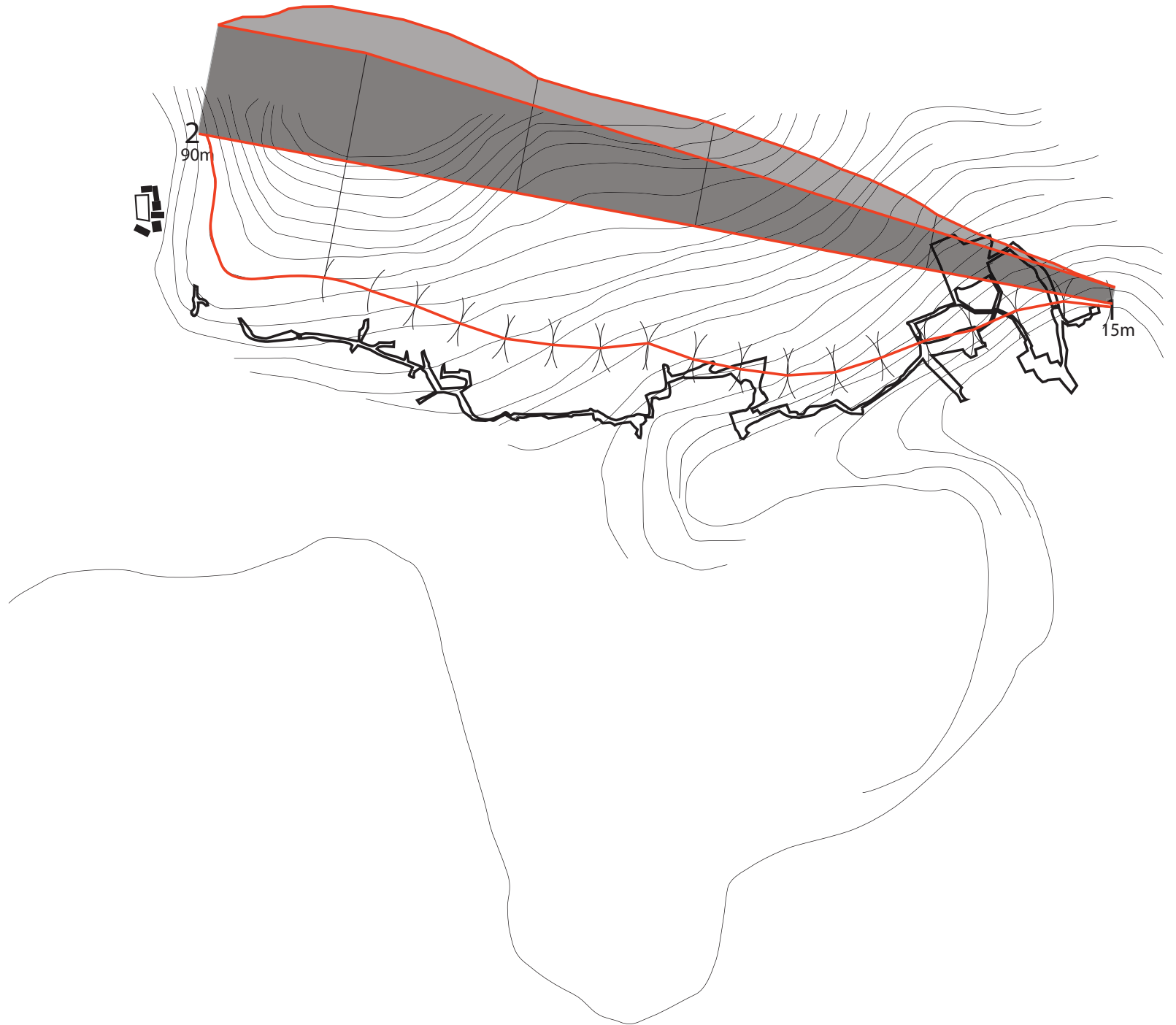

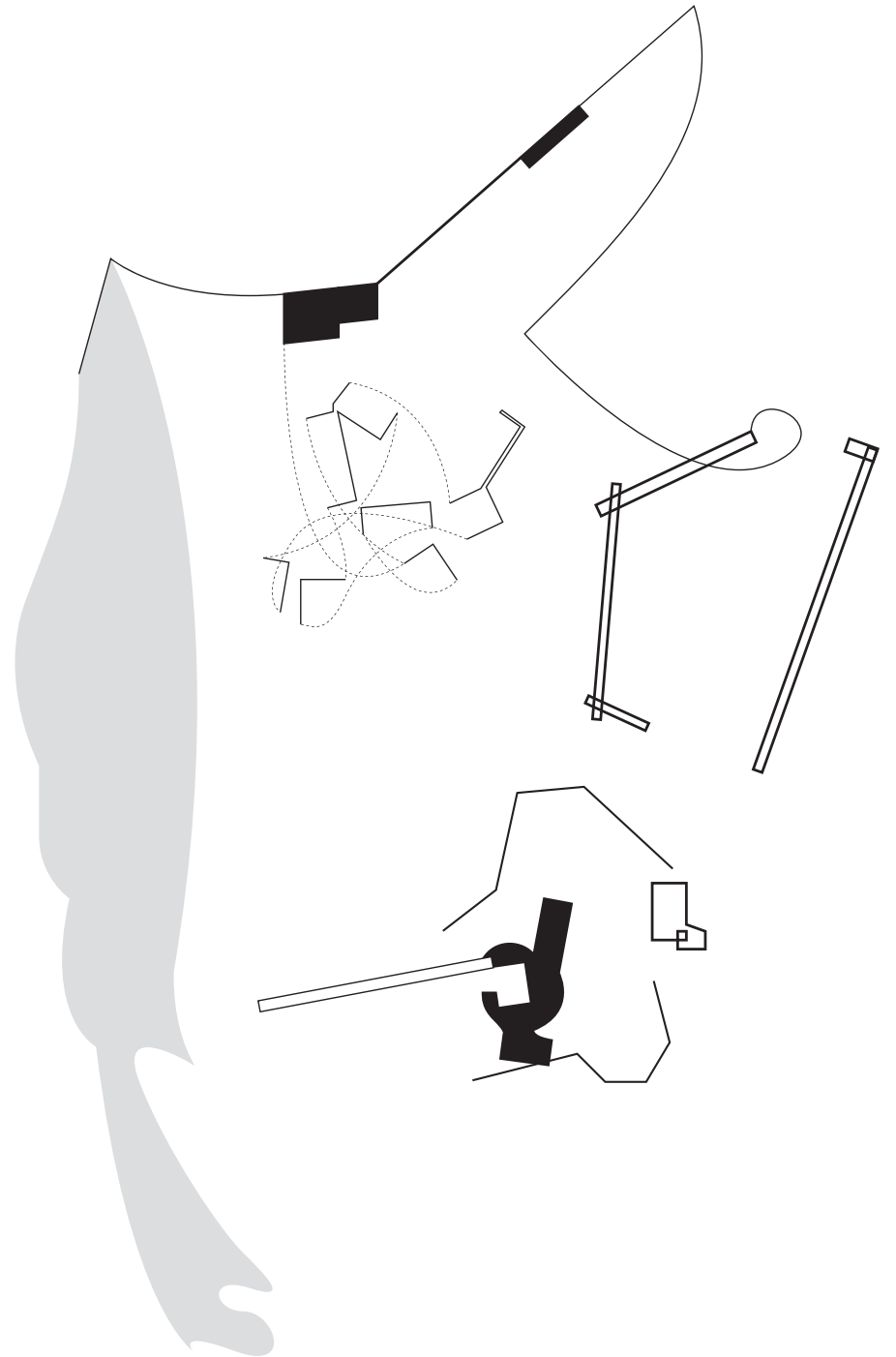



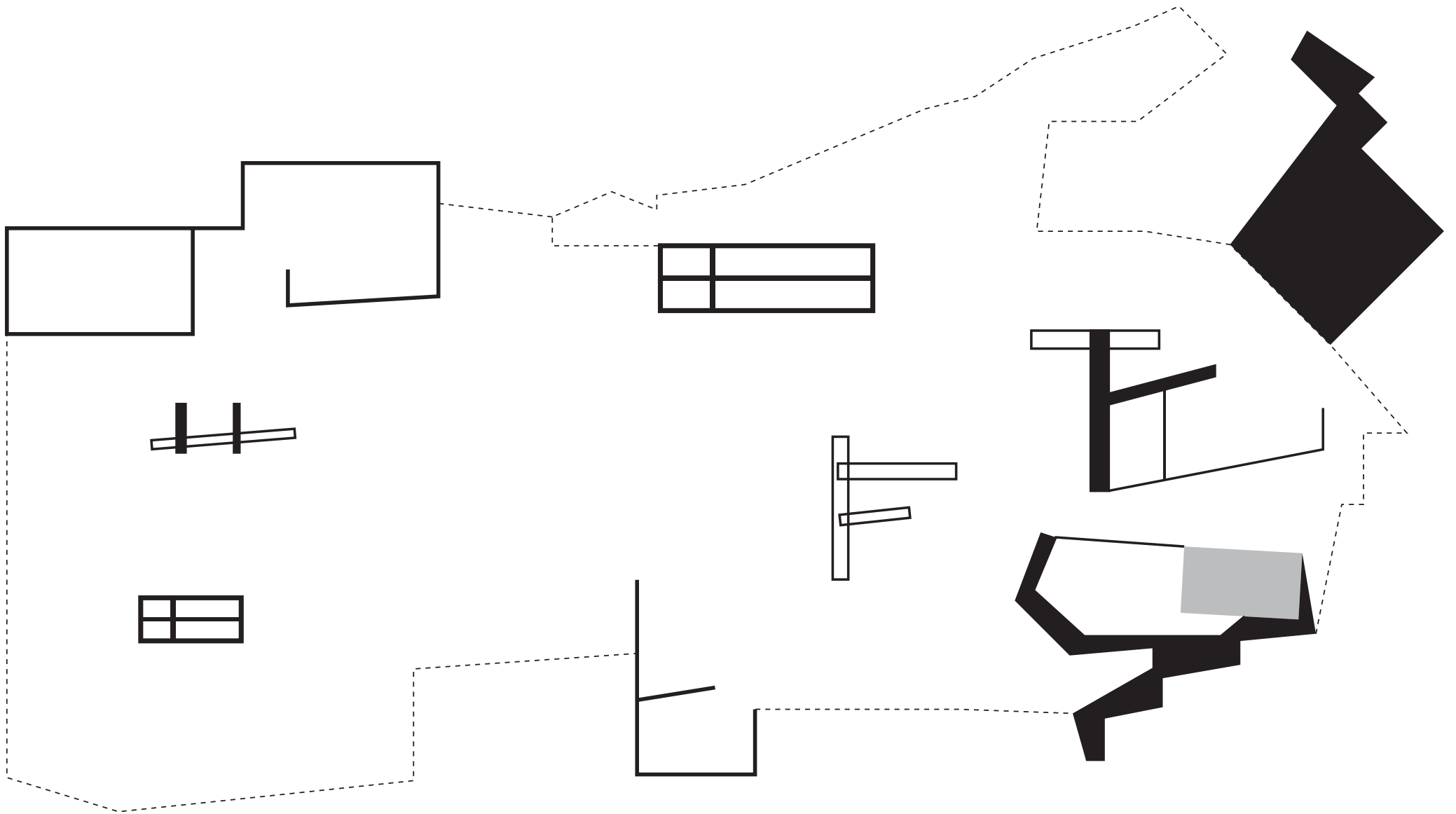

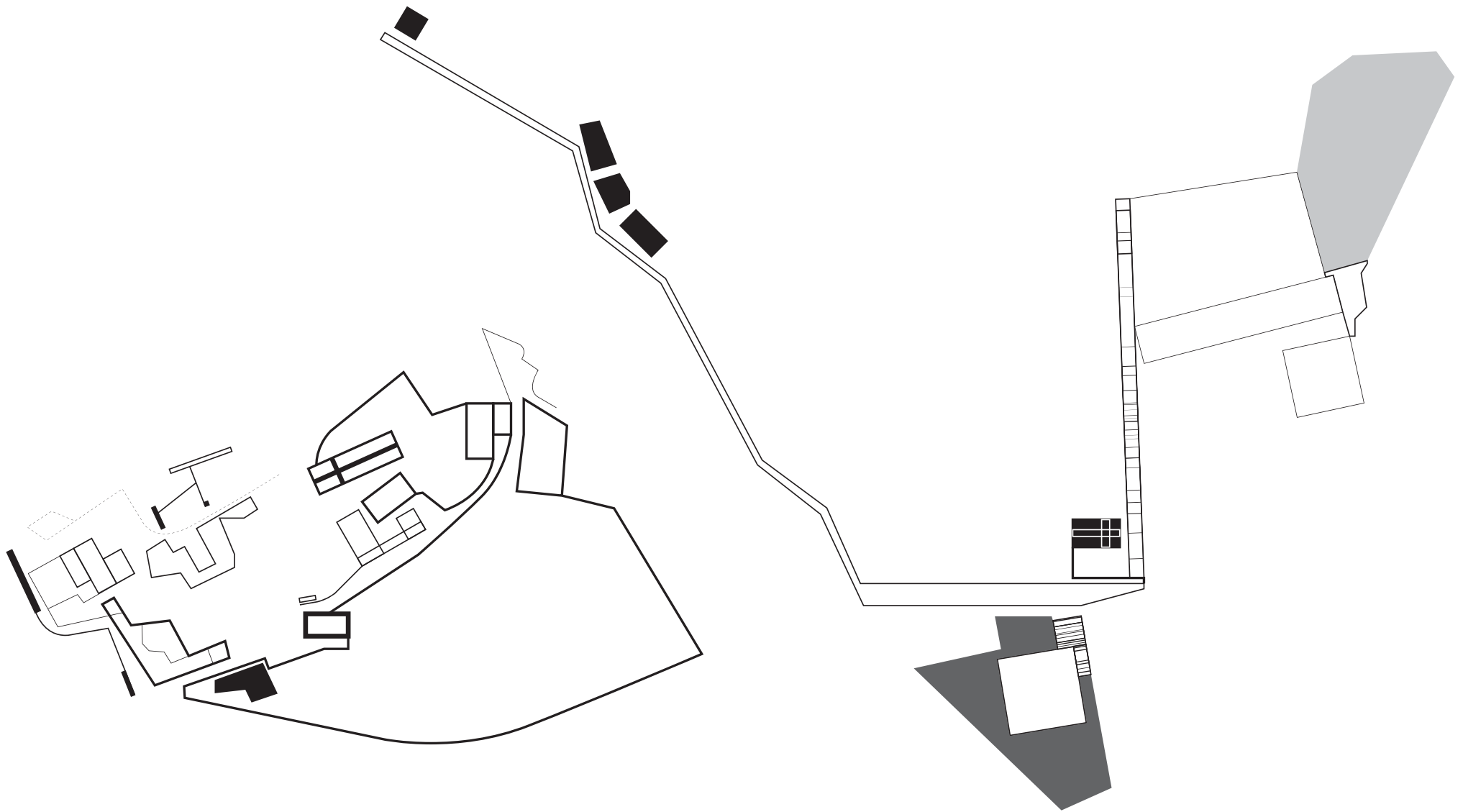









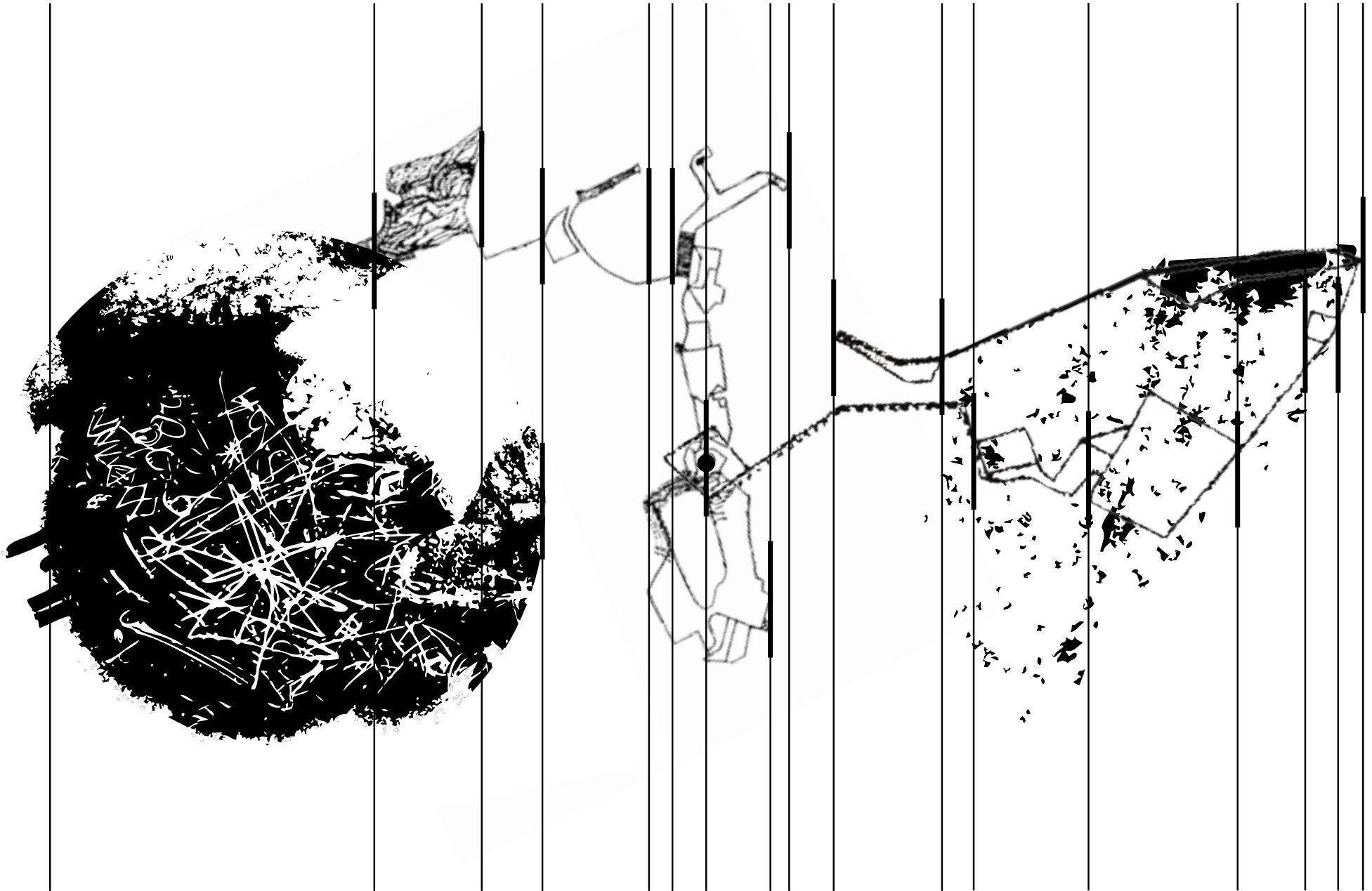

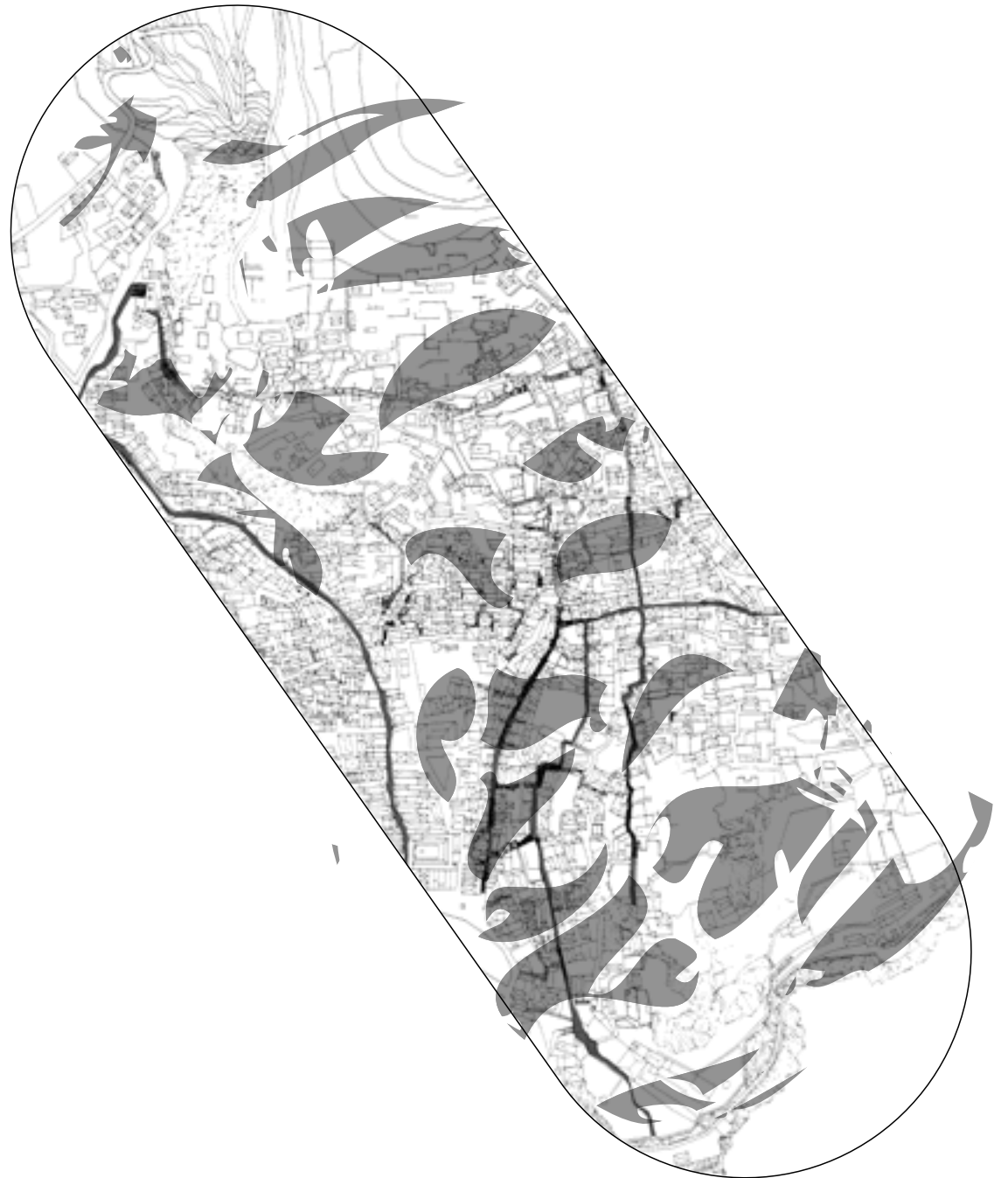
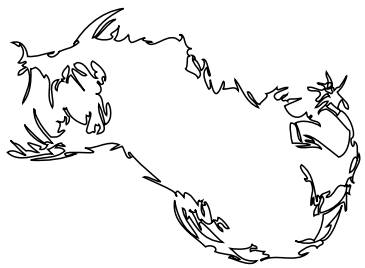

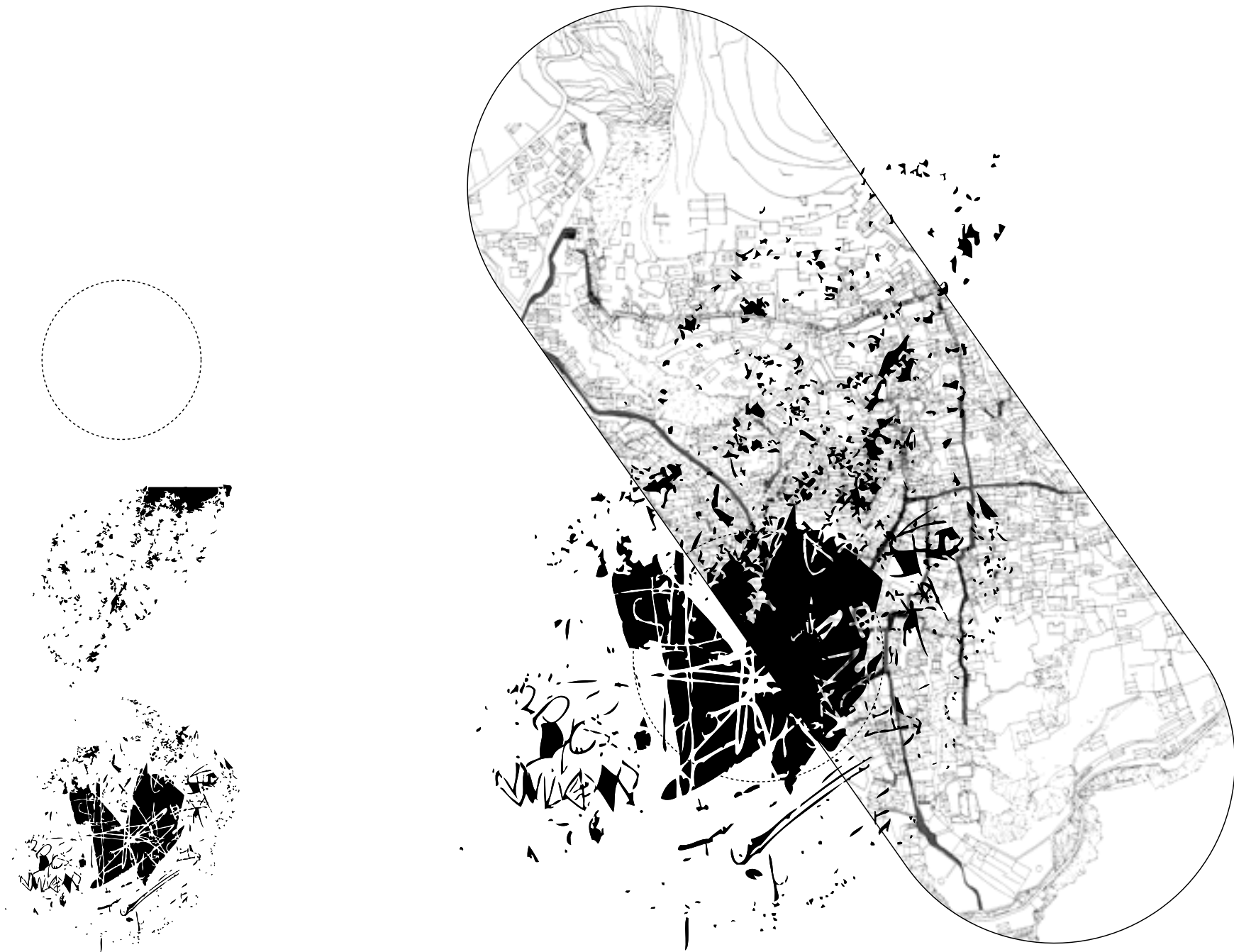

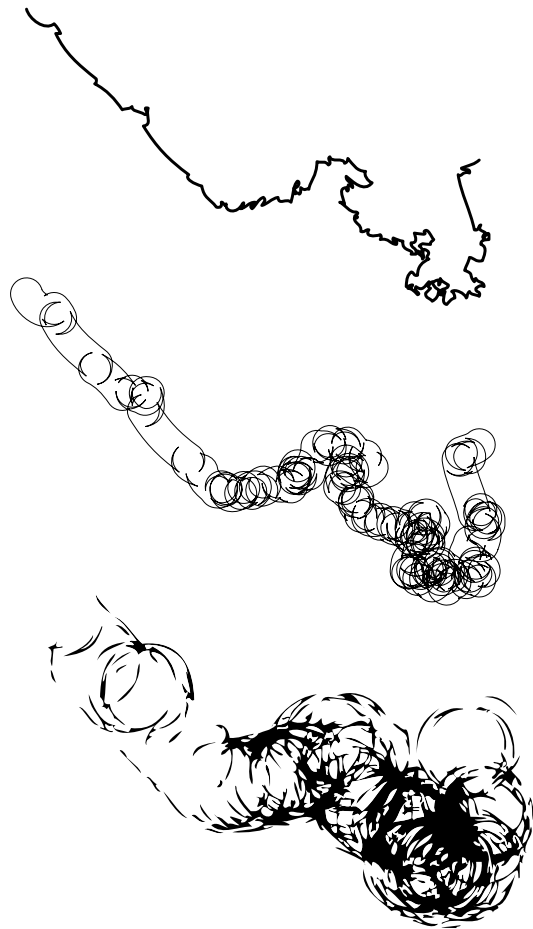

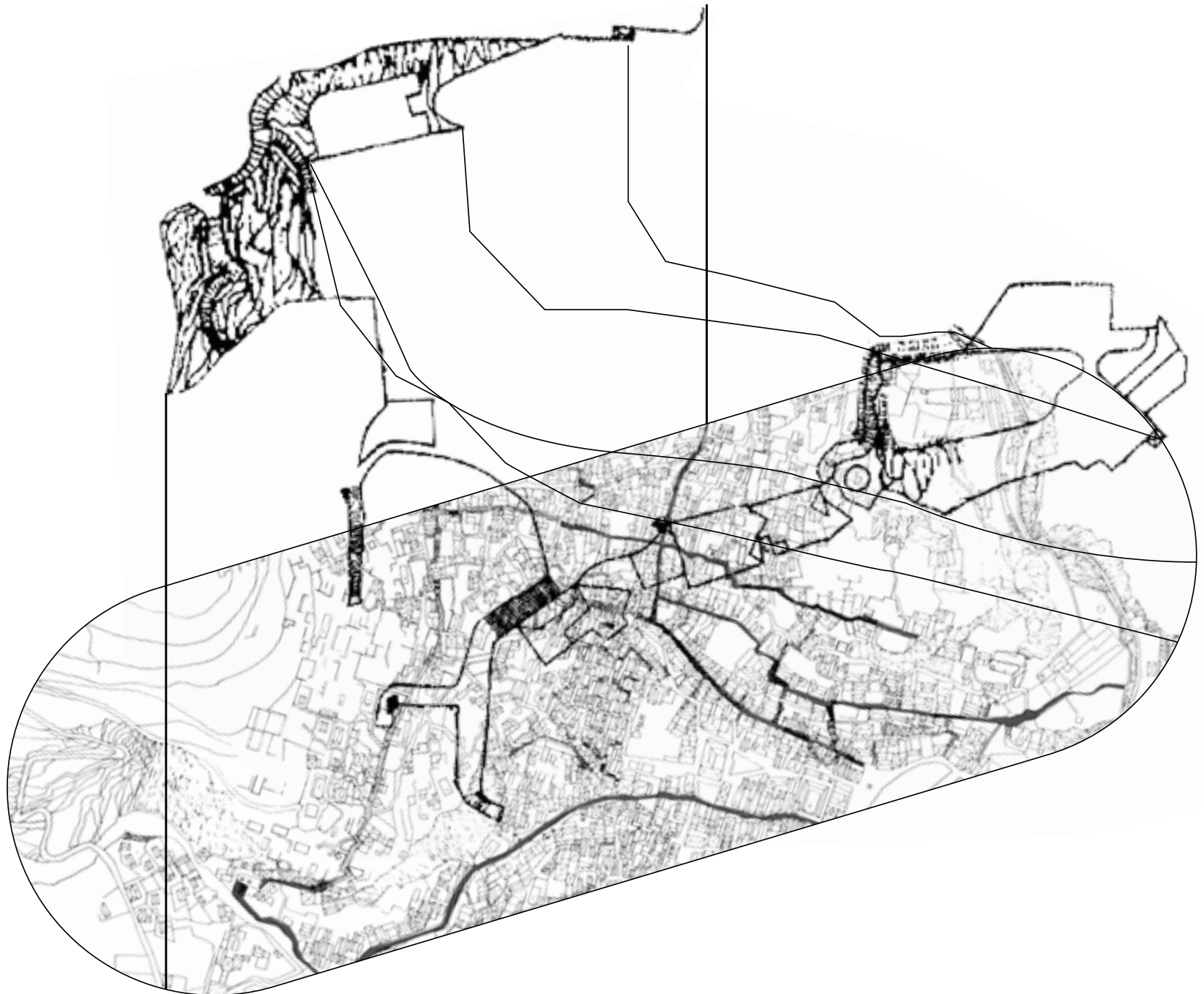

TAKT I RUTEN

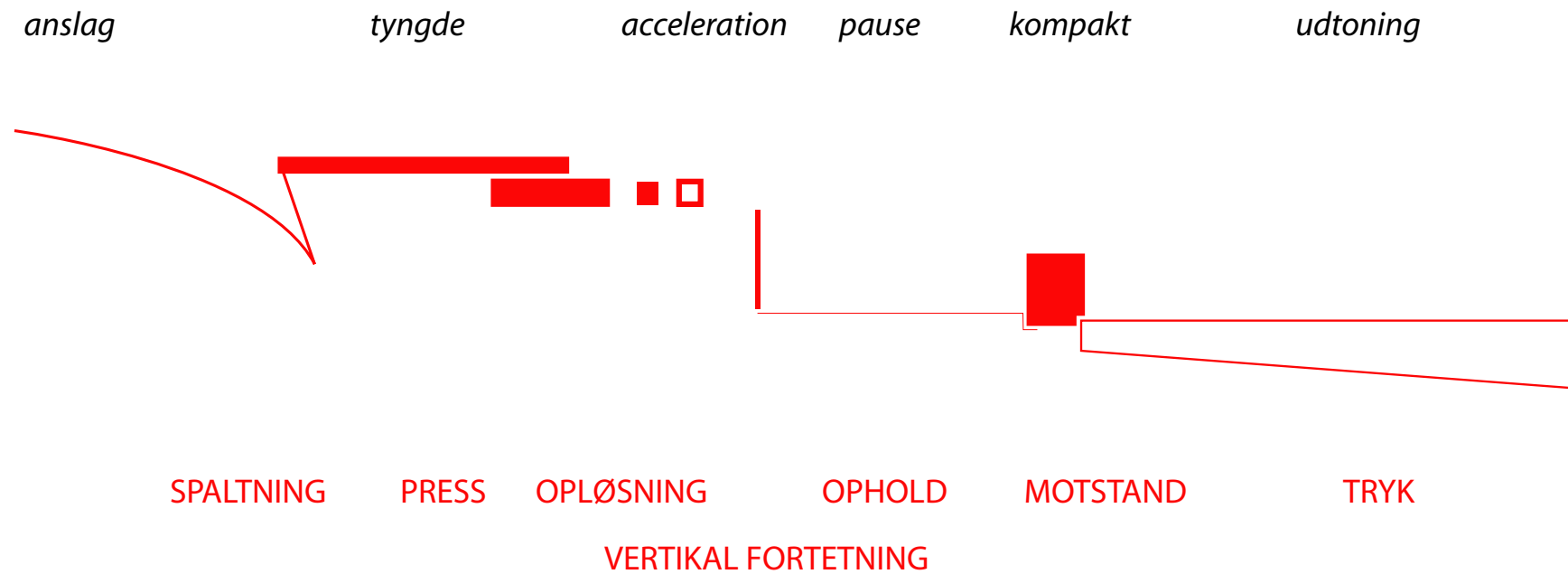

kyrkorna punkterar ruten o danner pauseringar





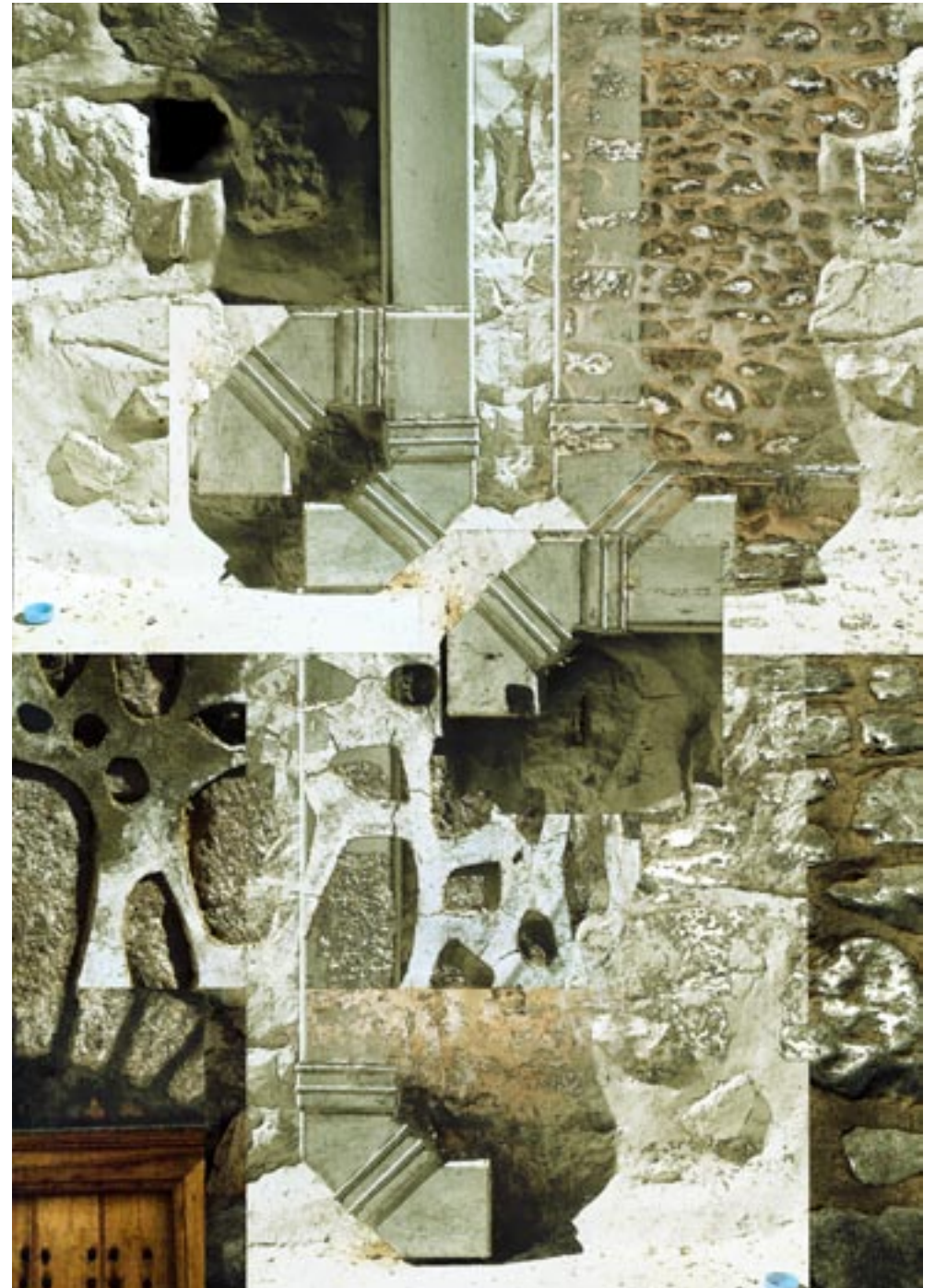



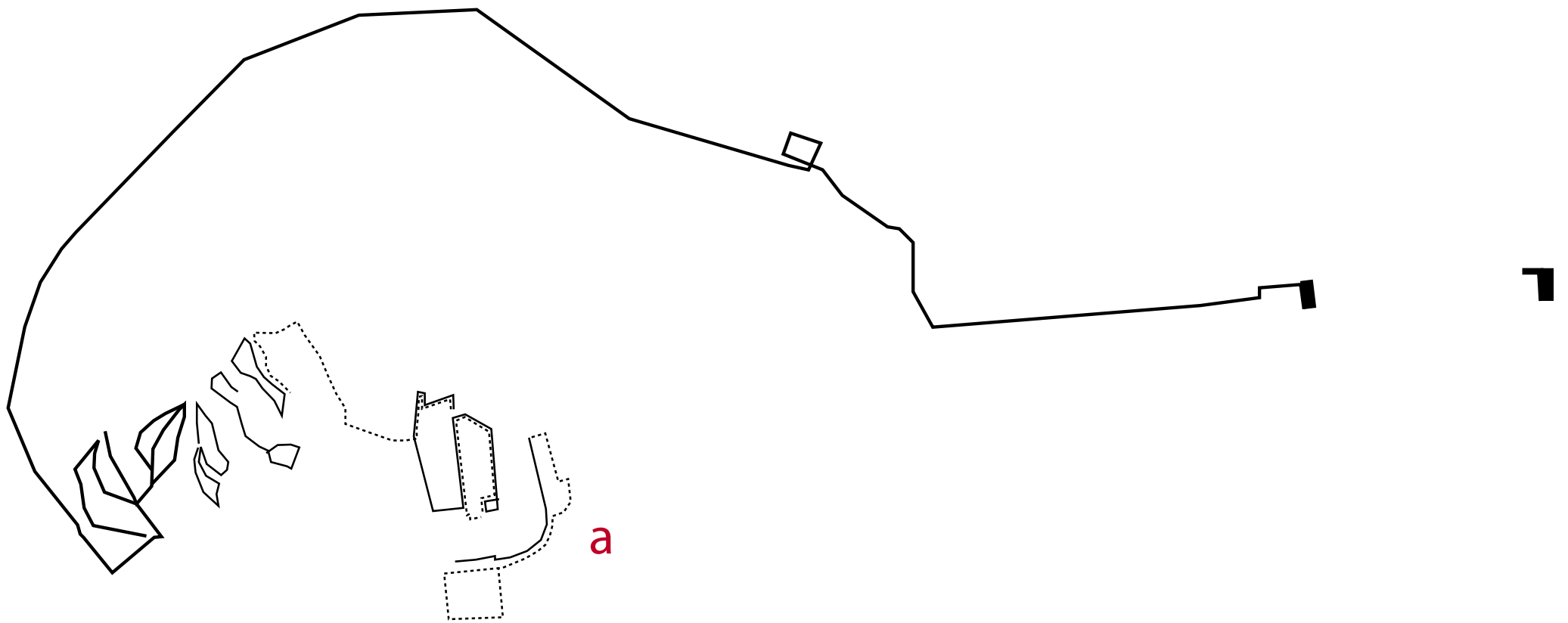

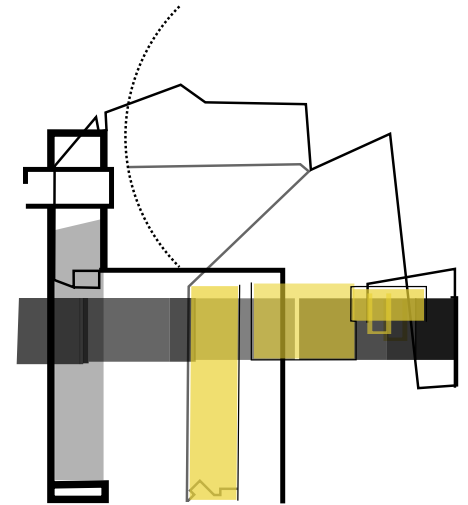
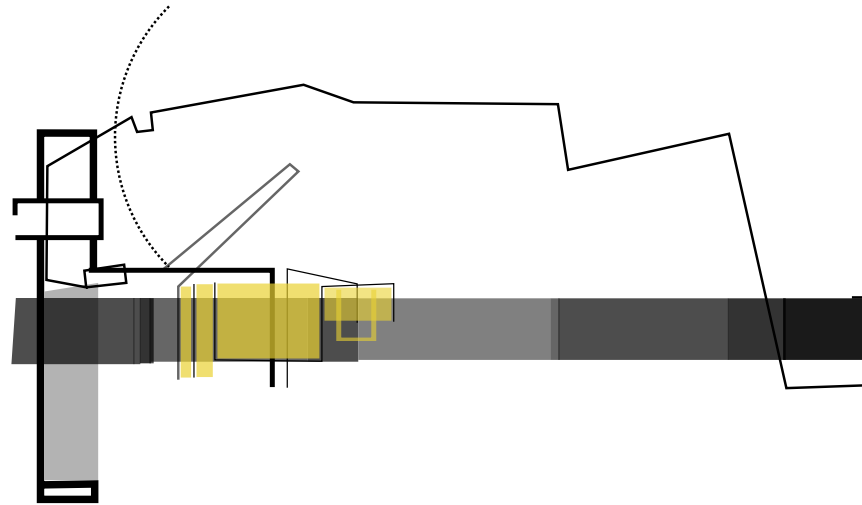
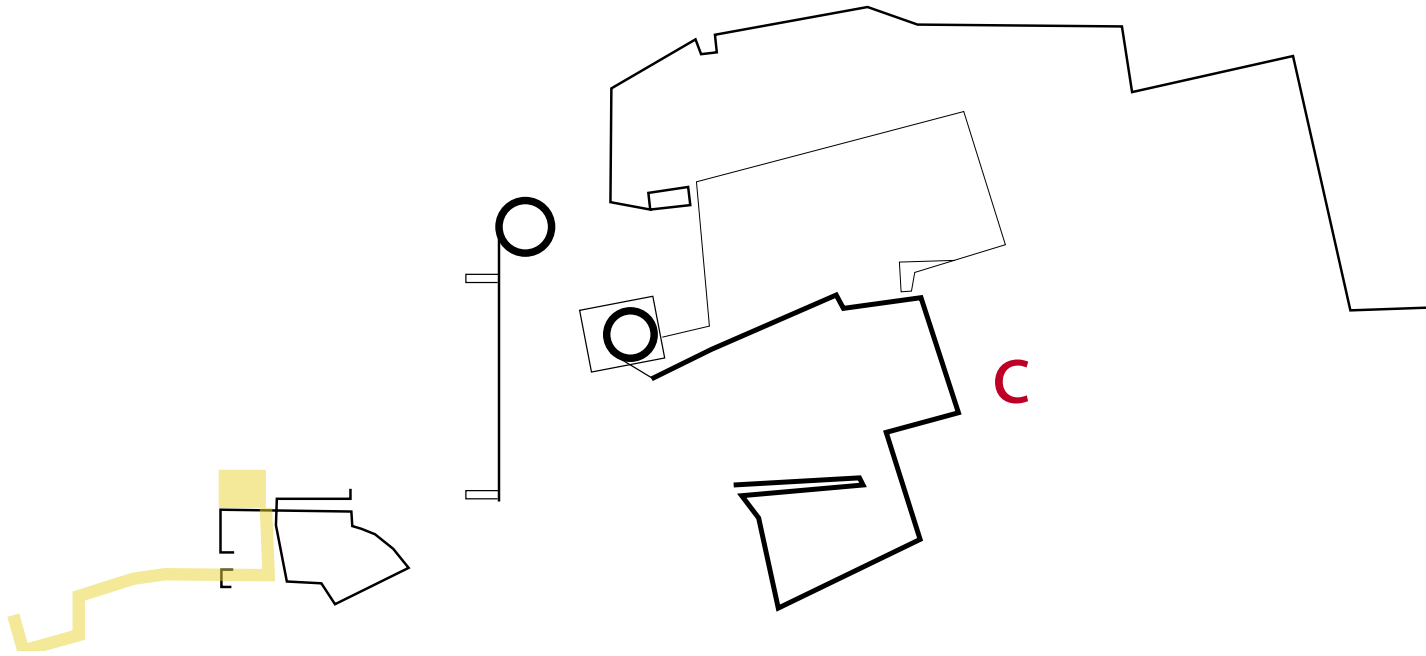

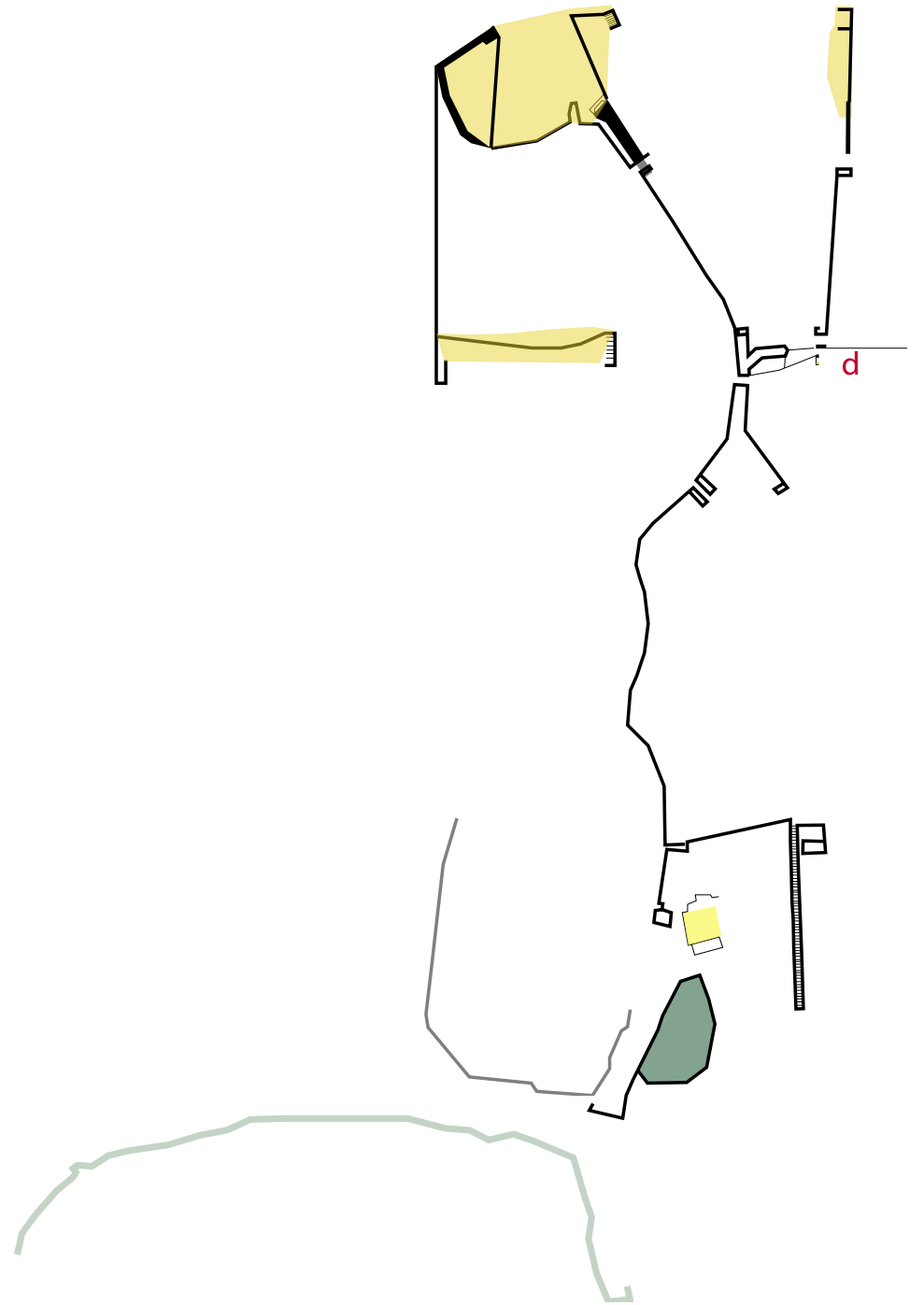

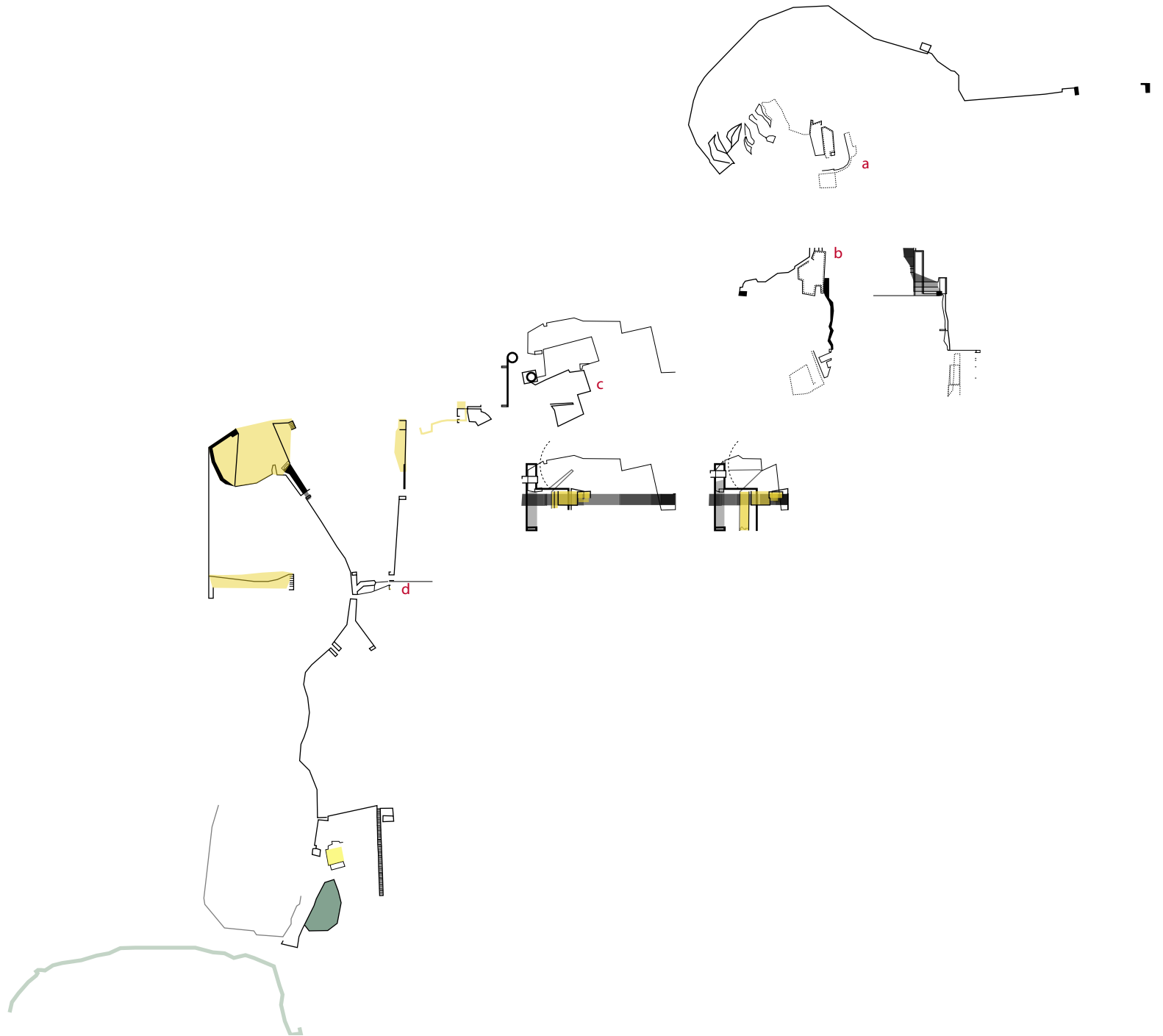

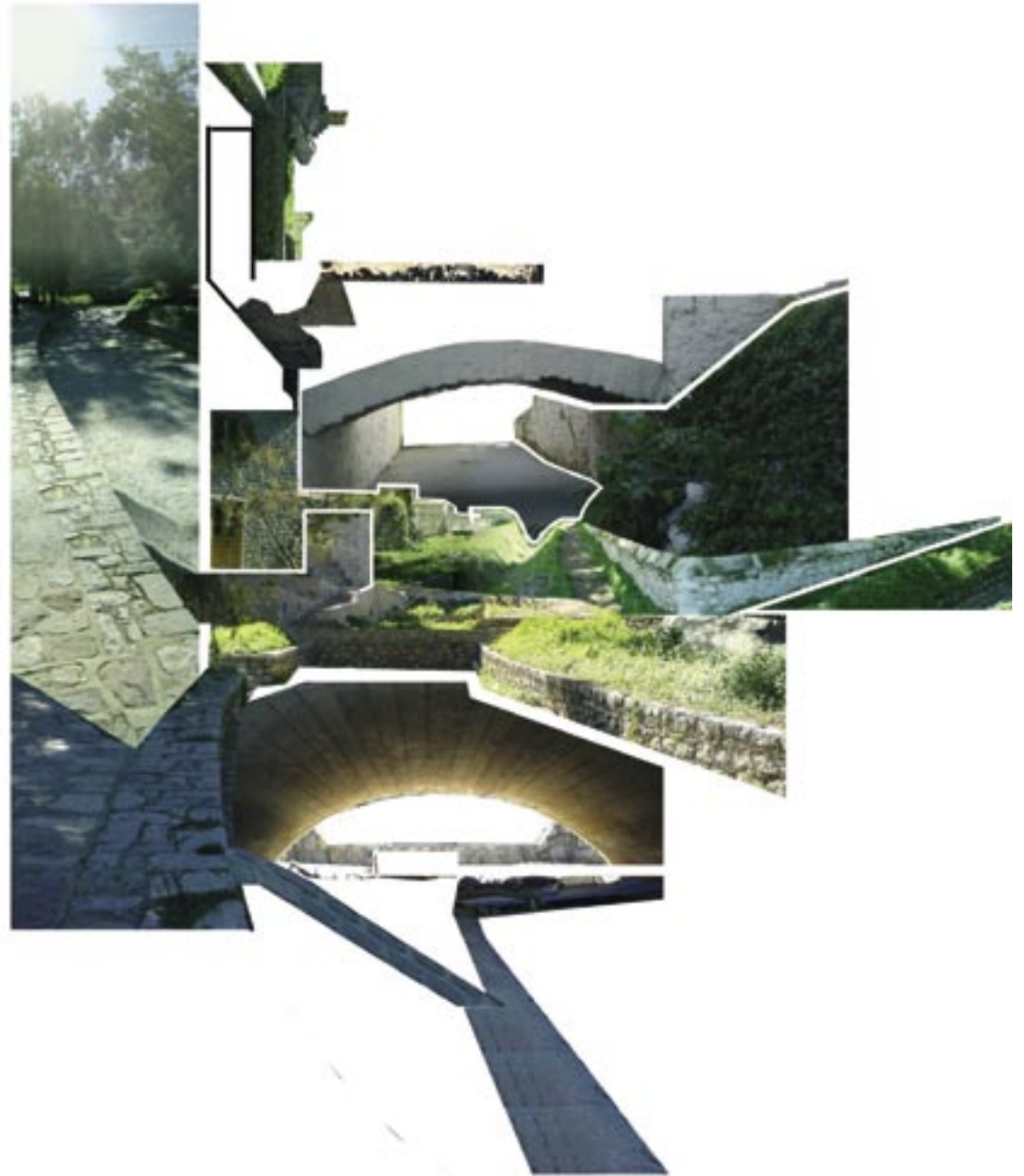

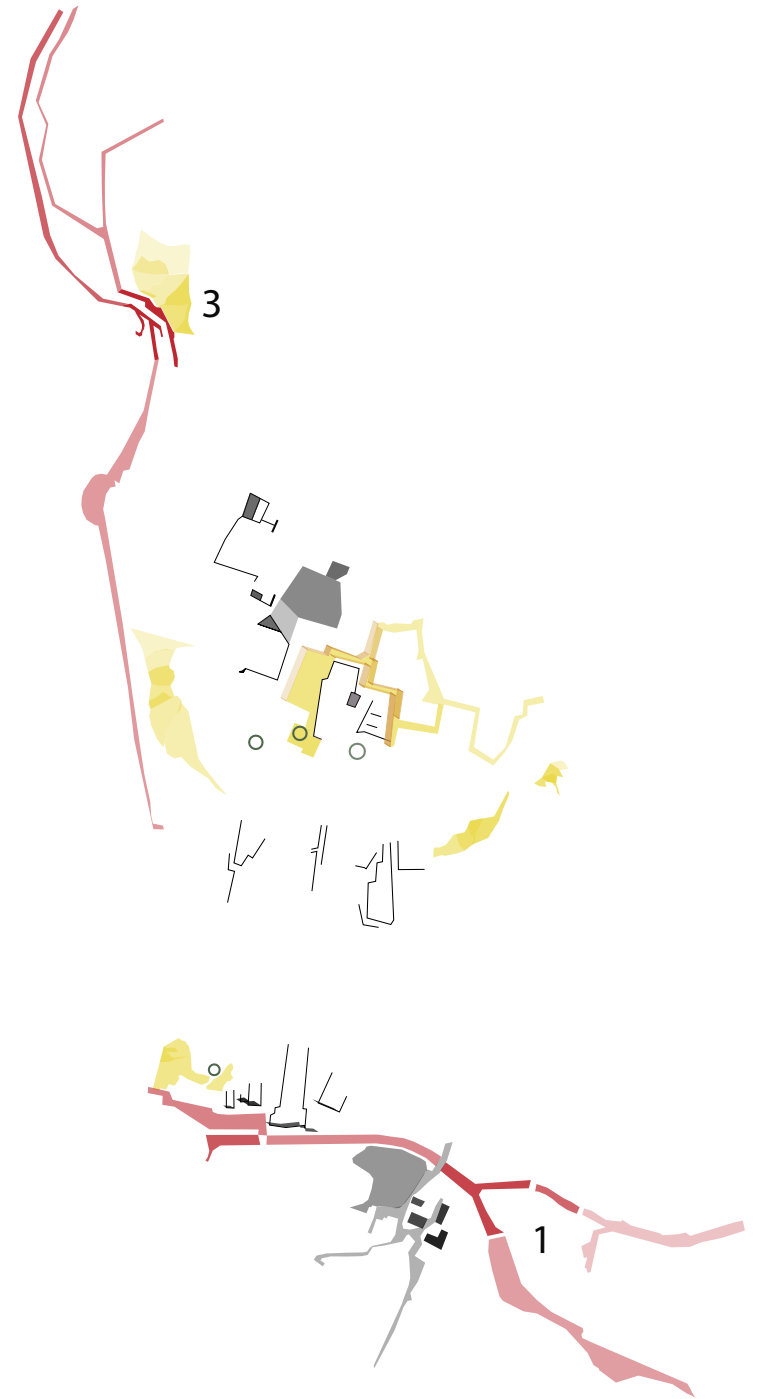

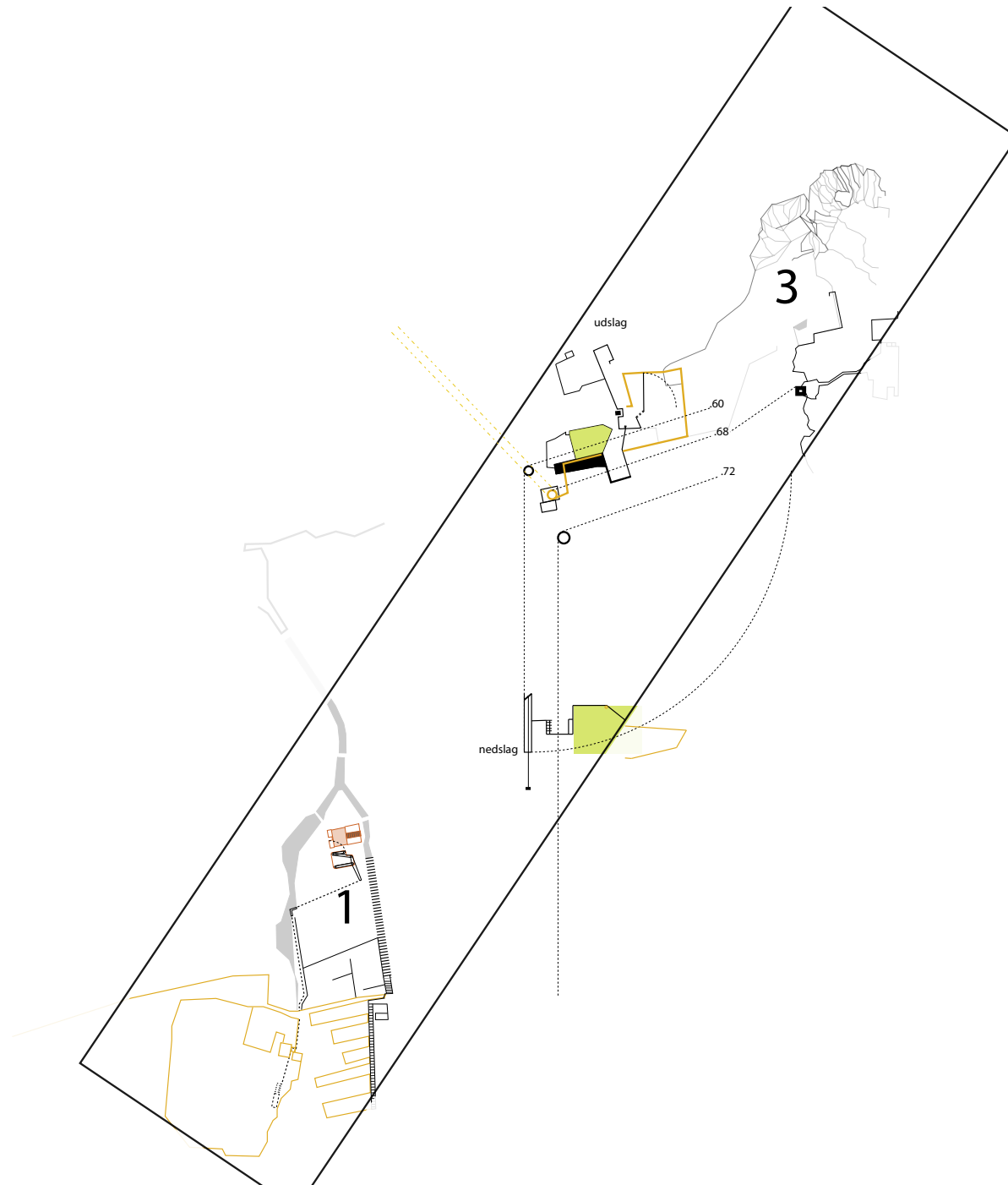

HYDRA 3 SOMMERSKOLE 2006



FORELÆSNING DEN 6. MARTS 2006 KL. 19.00 - HOTEL THEANO



KASPER NEFER OLSEN

FILOSOF. PARIS

transformation fra 2 til 1



maskine-dele a-d

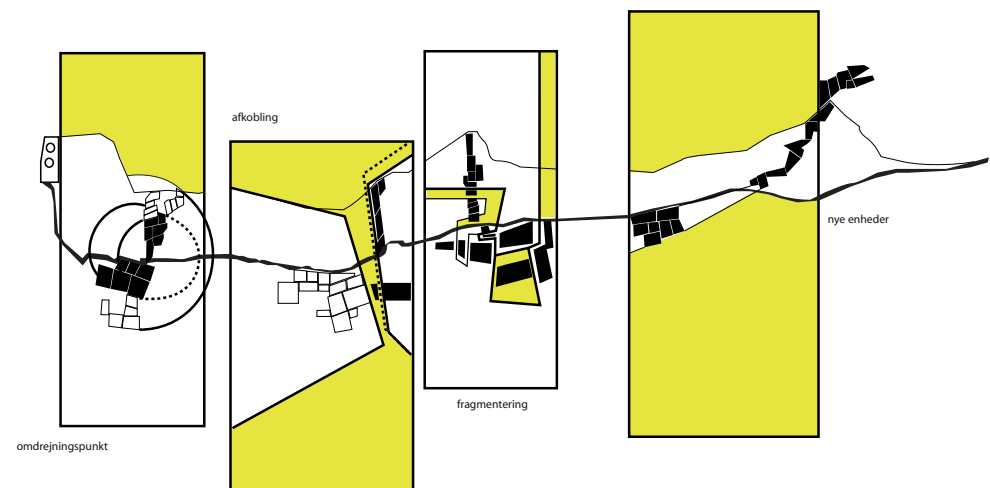

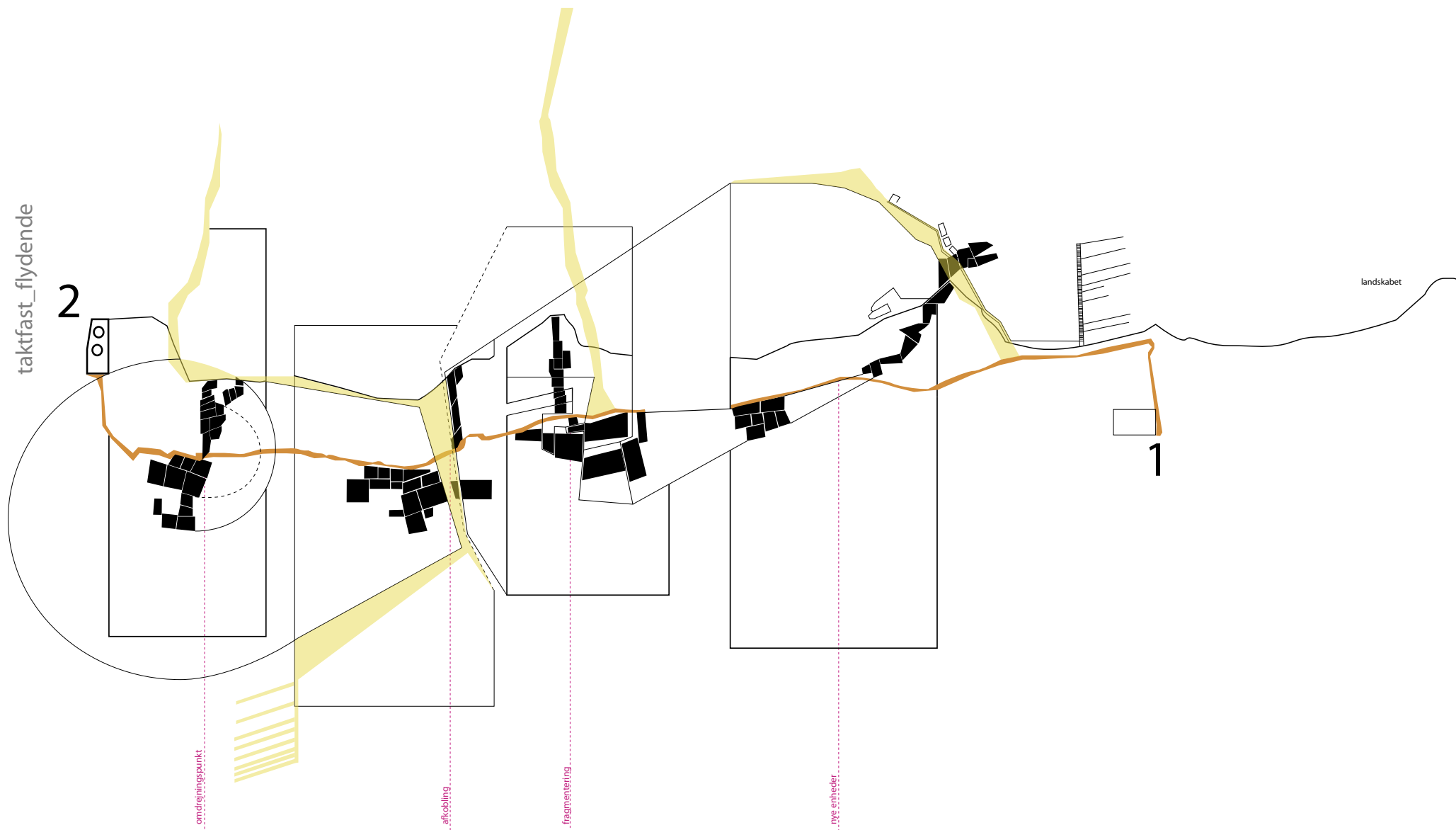

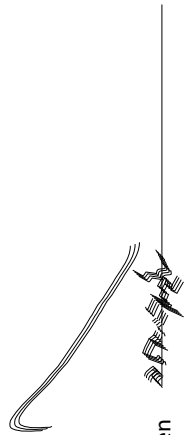
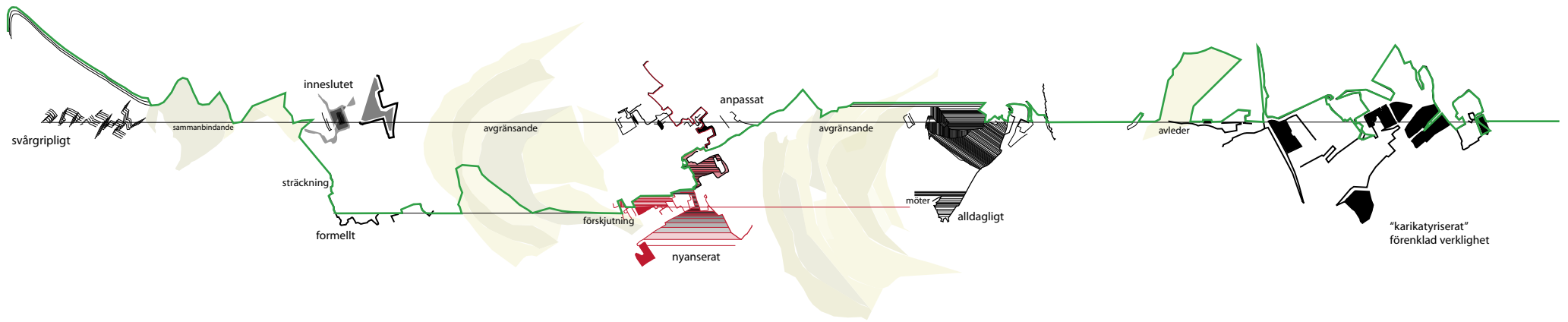

Torde man tala till himlen



På stjärnhimmel
kan man se dina ögon



Goddag herrn.
Tack herrn.

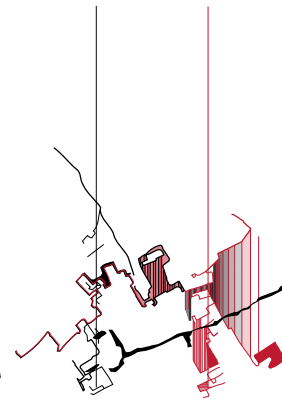

Vill ni ha hjälp upp, tant



Räck mig olivoljan
är du snäll

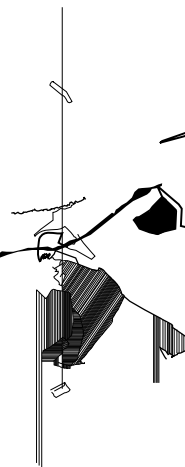

Tja! läget o sånt
hitta knappaast lätt



Va f-n tjollan e stängd



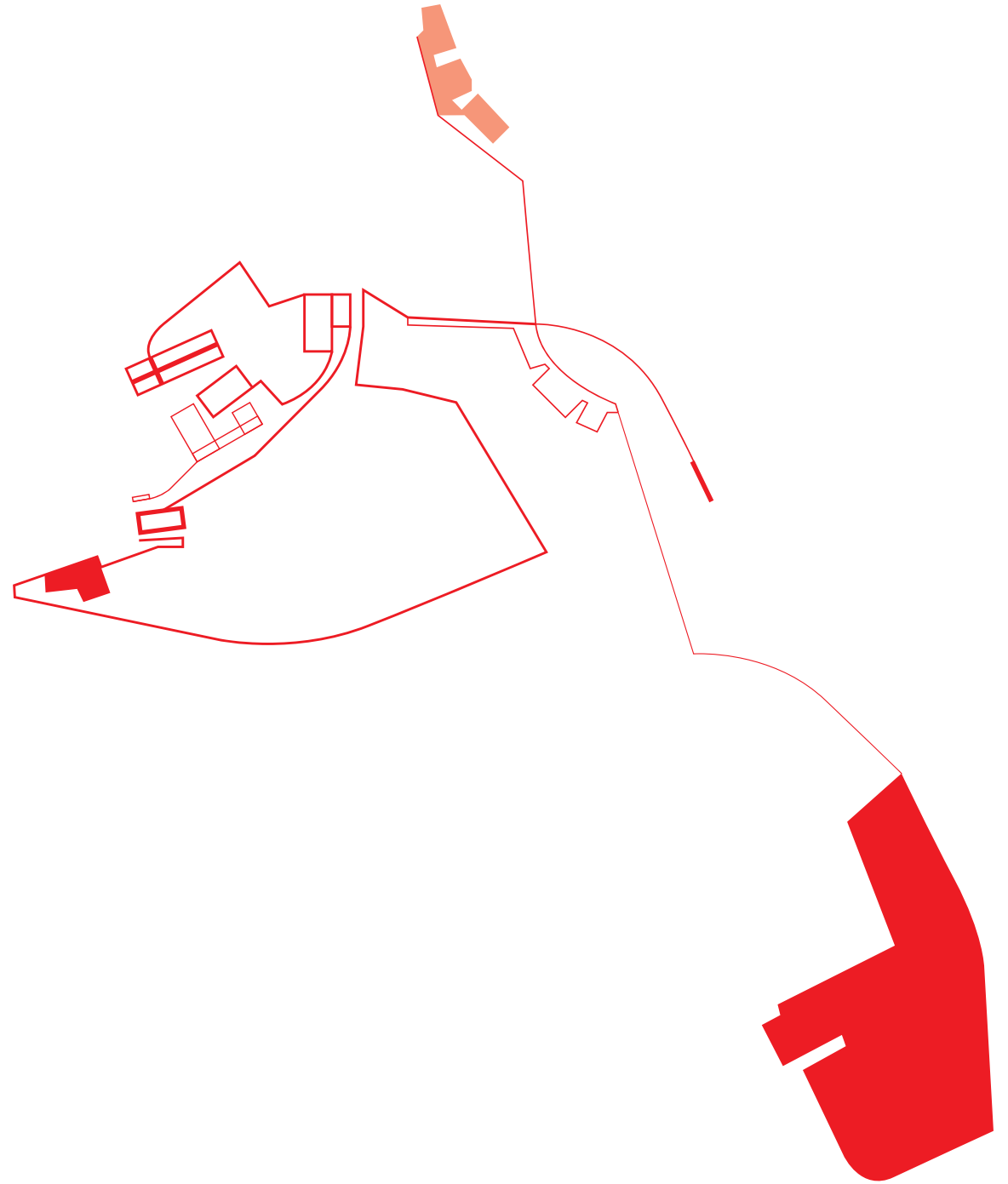

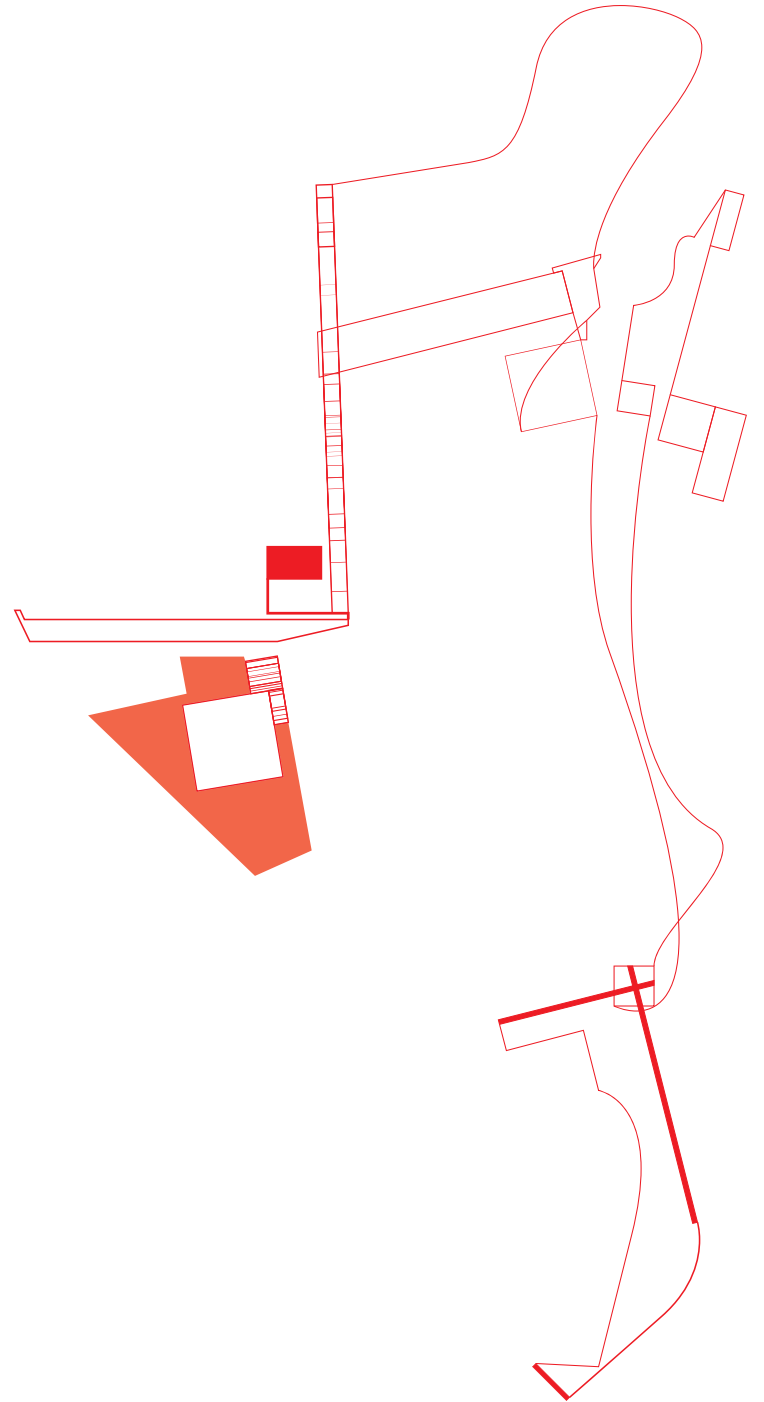

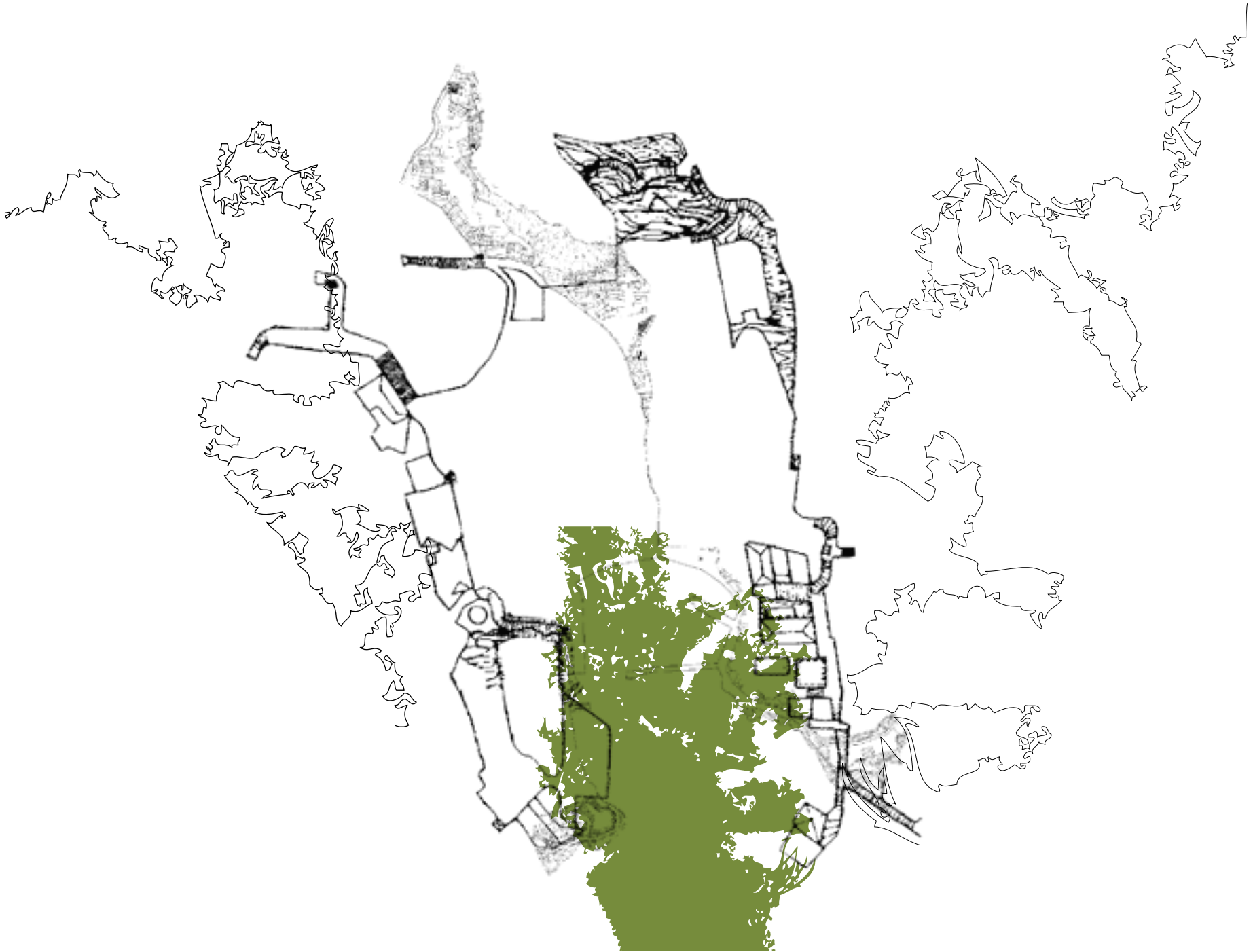

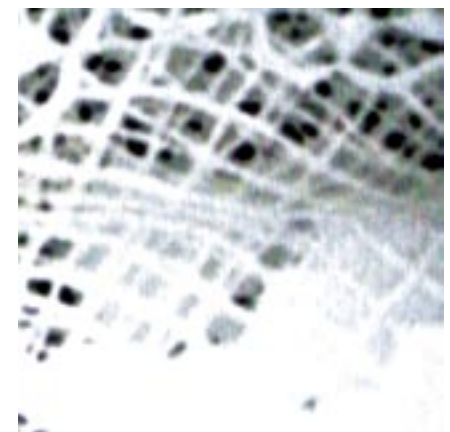
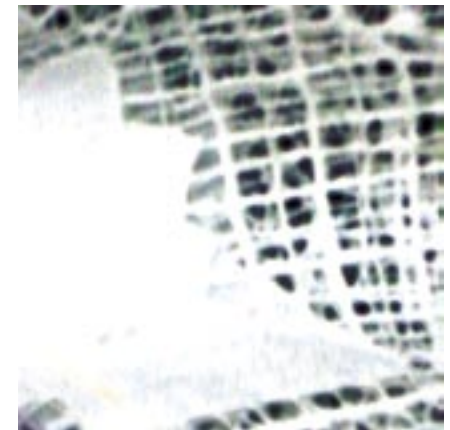
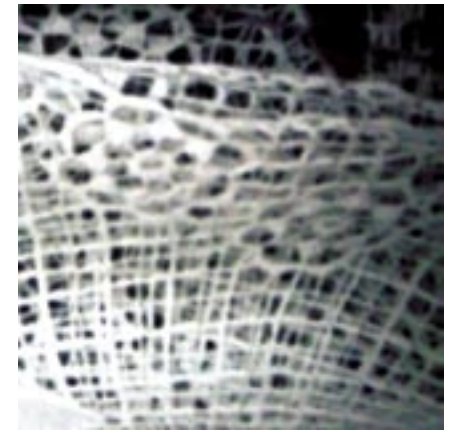
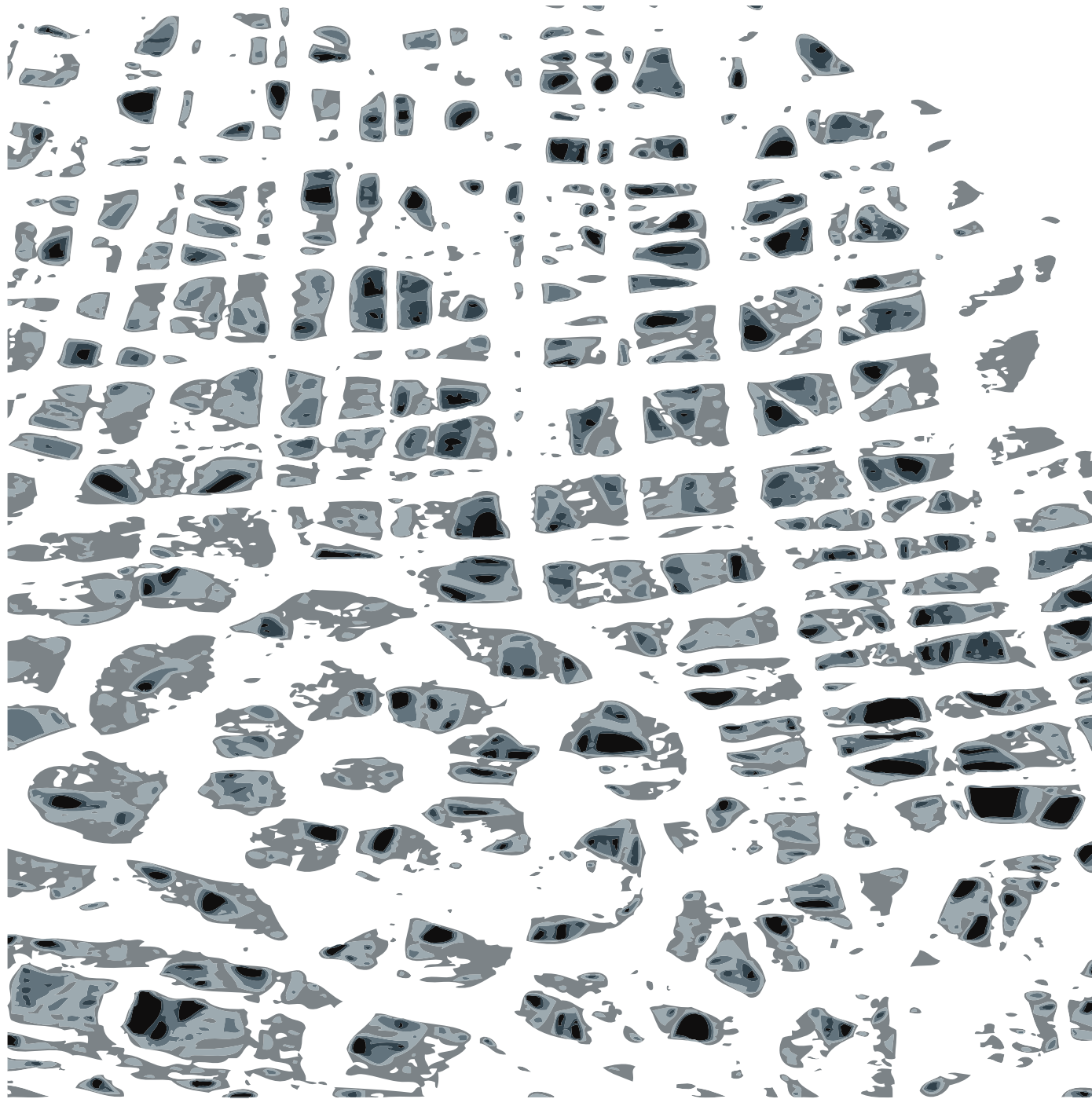

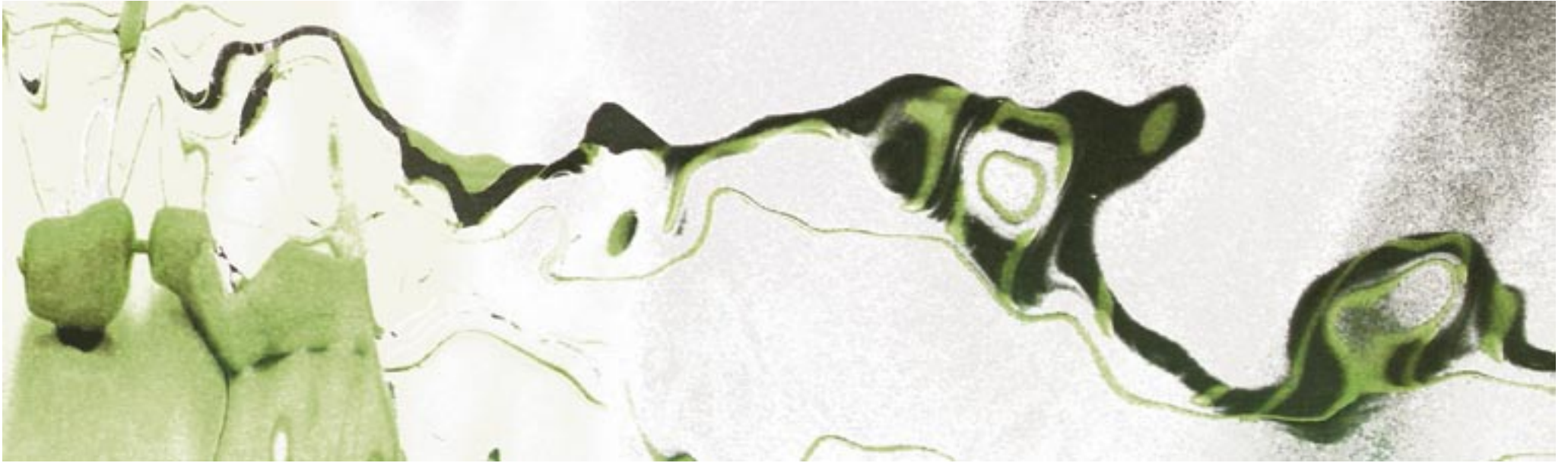

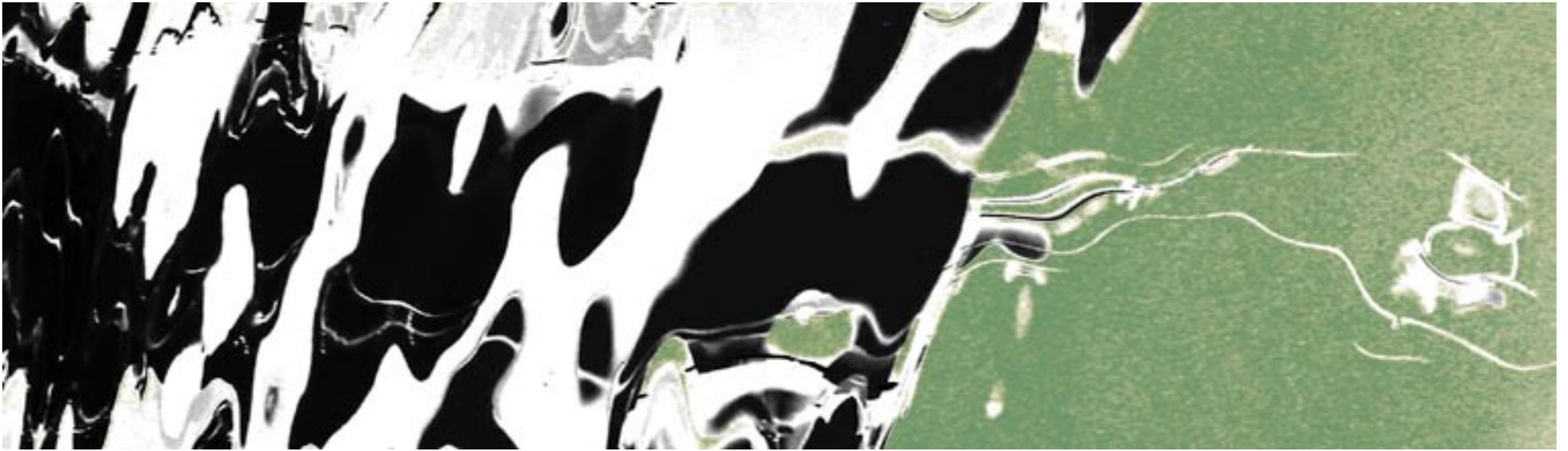
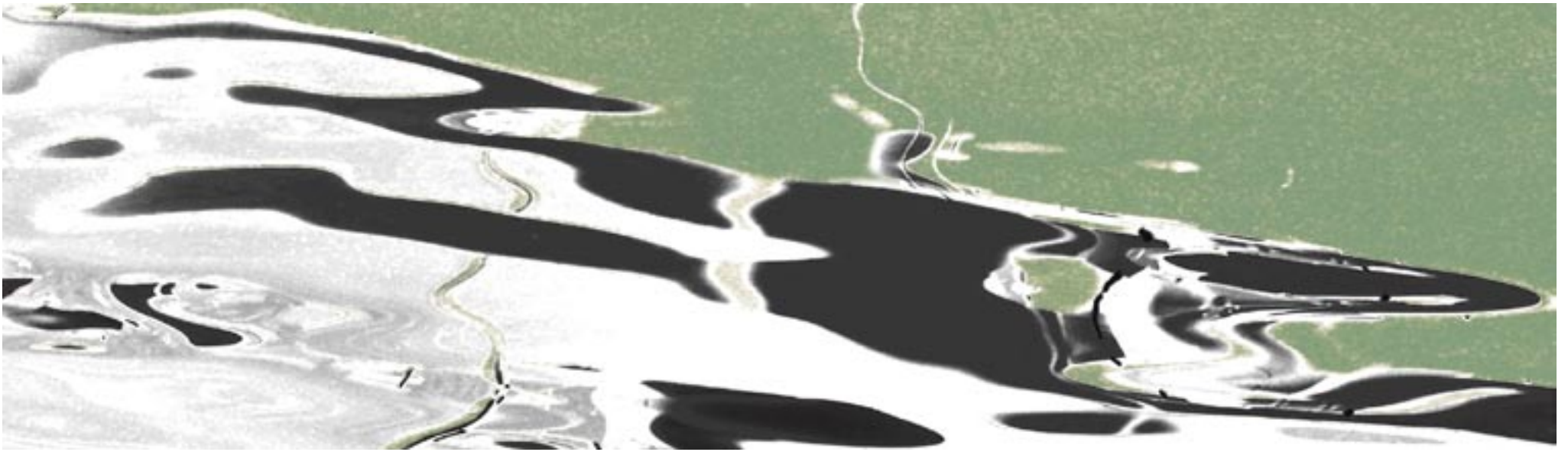

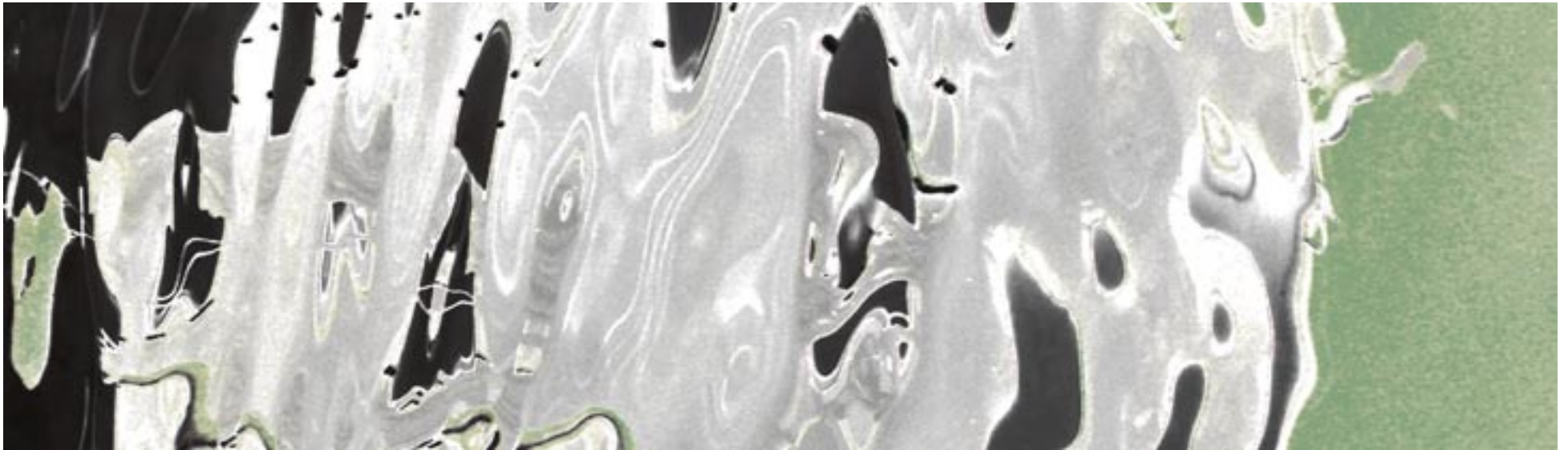

a



a+1

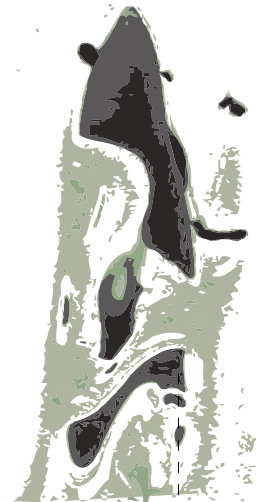

a+2

*Livet kan karakteriseres som en bevægelse hen imod stilstand.
:Michel Houellebecq*

Arkitektonisk produktion kunne operere under lignende forhold i det man insisterer på en eller anden form for korrespondence imellem verden som vi oplever den og de produktioner vi tilfører den igennem en skabende handling.

*Det vil sige, at forholdet imellem det flydende (fænomenerne) og det faste (arkitekturen og naturen) kan karakteriseres som en glidning, med forskellige mellemtilstande undervejs.
Det er altså ikke i denne polariserede kategorisering man kvalificerer sit tegningsmateriale, men netop inde imellem yderpunkterne; ved at identificere, iagttage og producere mellemheder.*

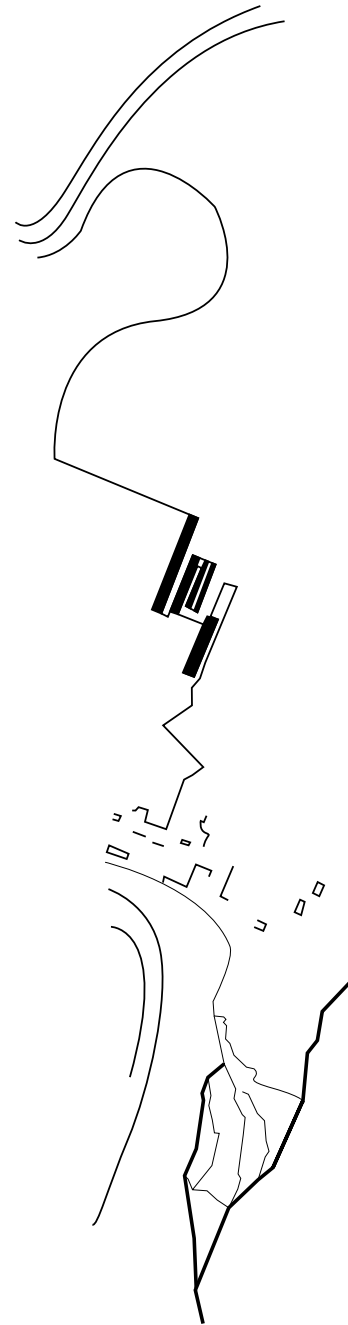

FLYDENDE

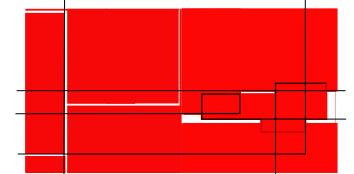

FLYDENDE

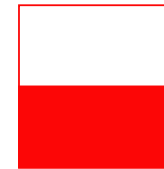

FAST



FAST

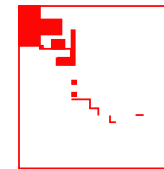
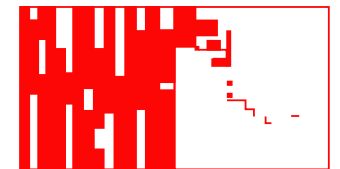

FLYDENDE



FLYDENDE



FAST

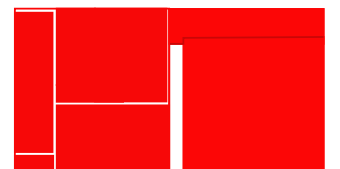

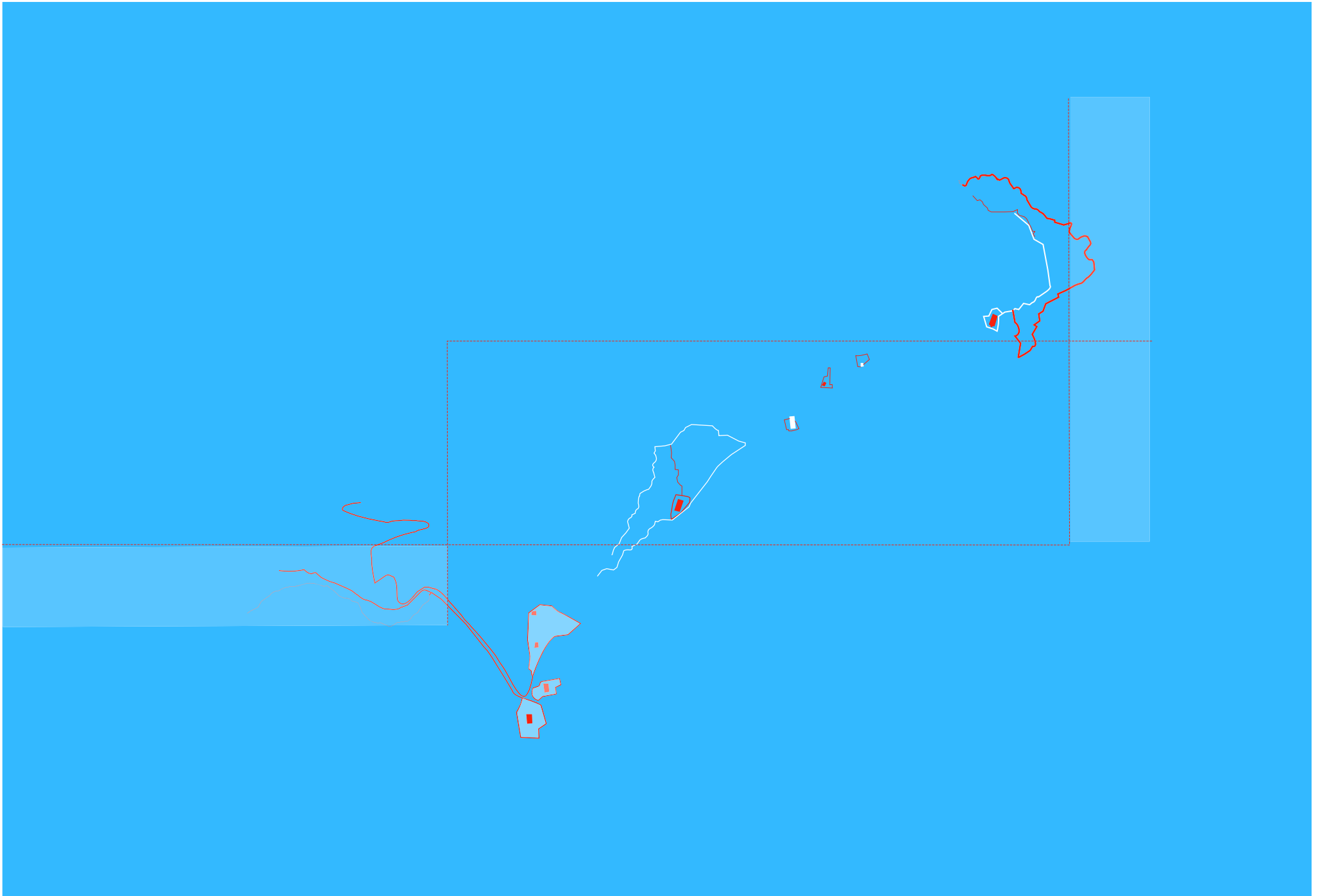

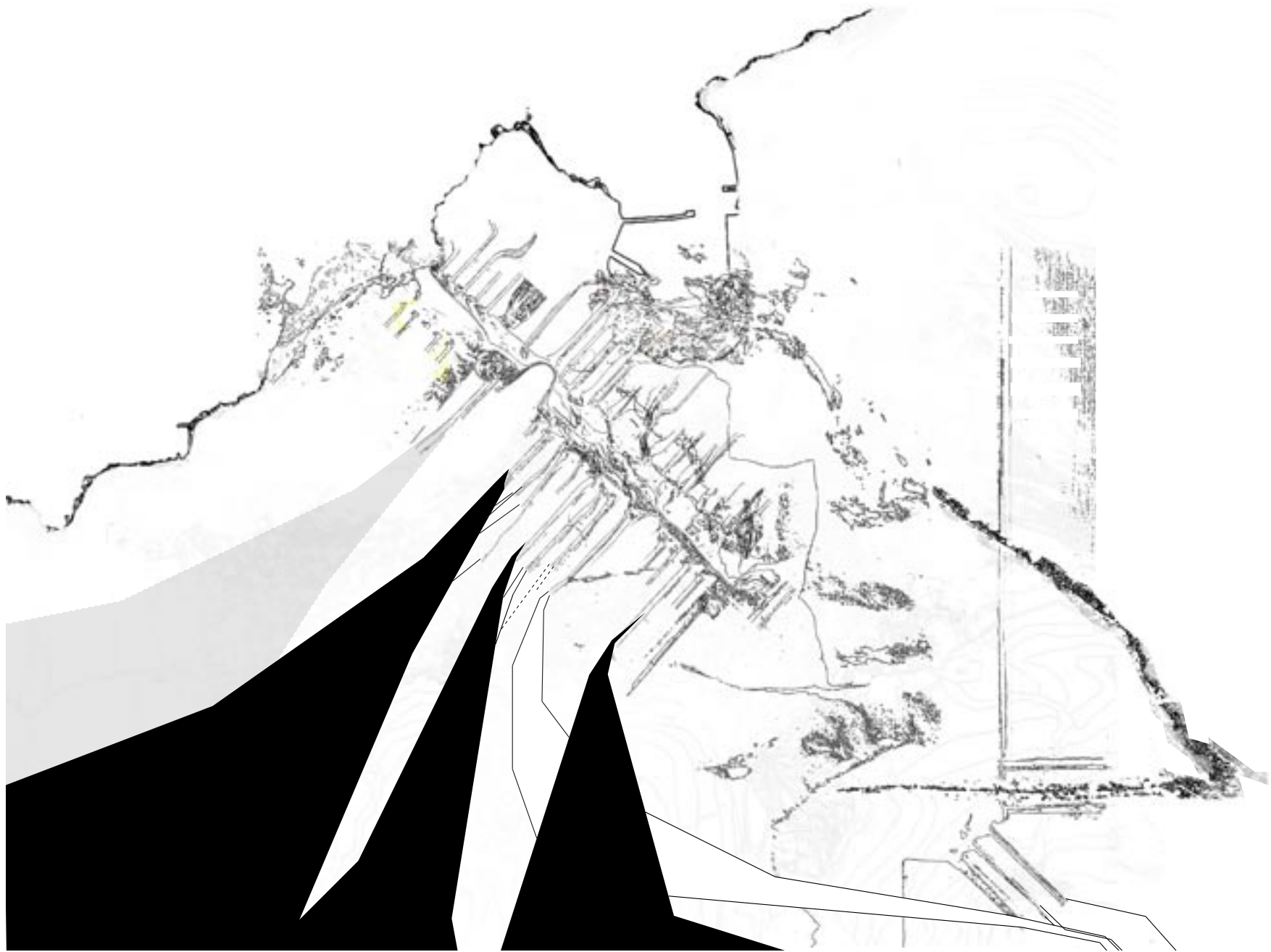

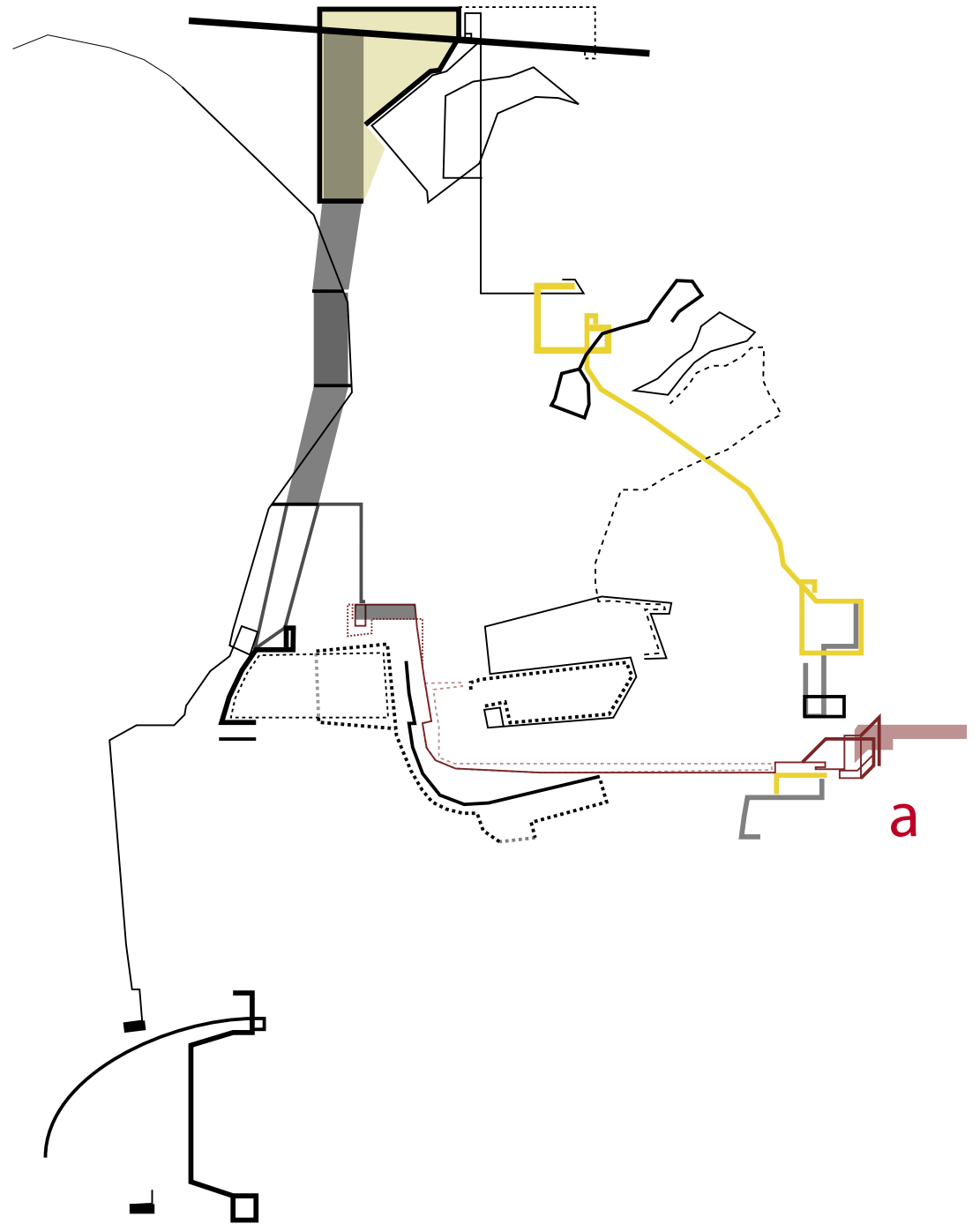

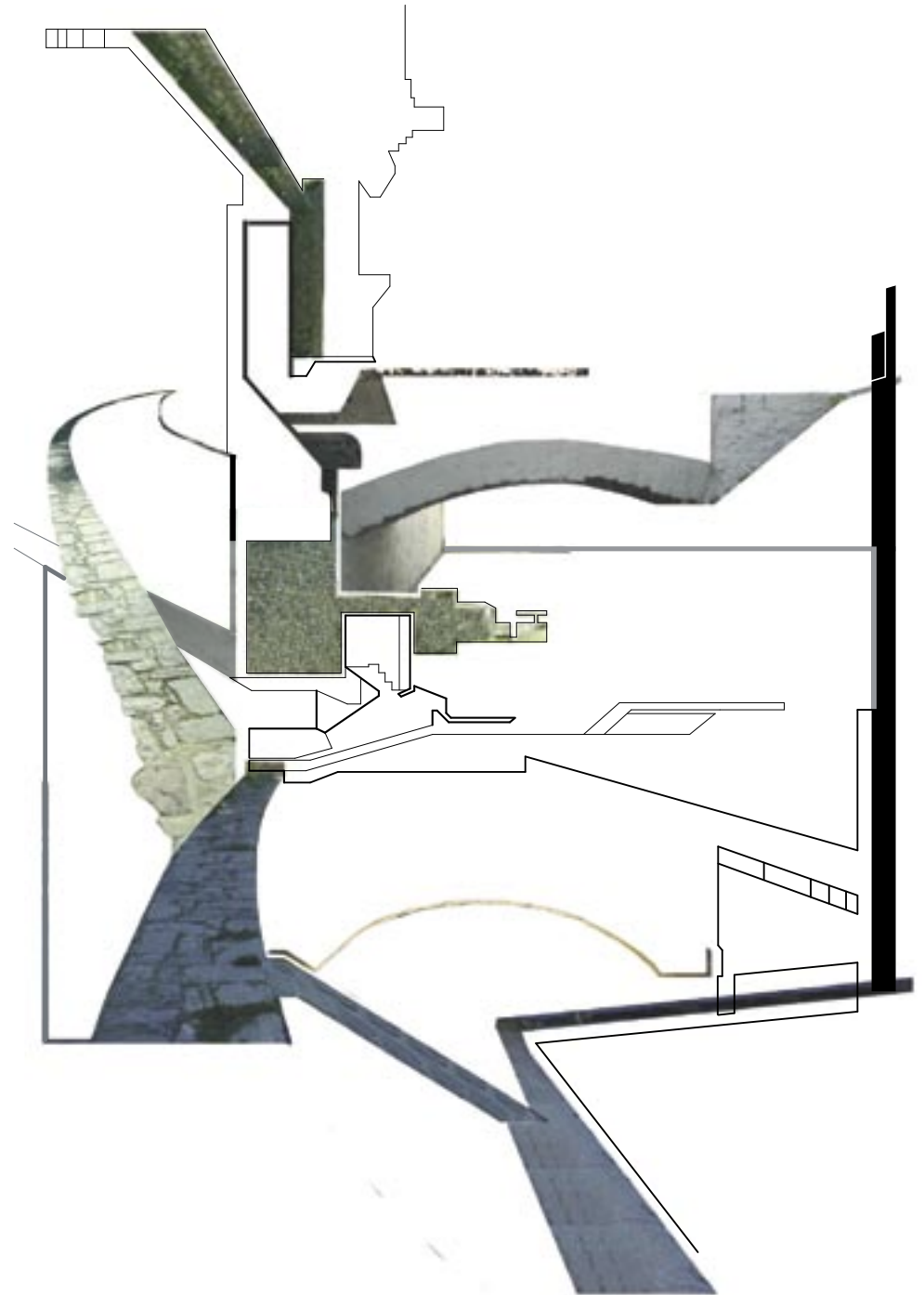

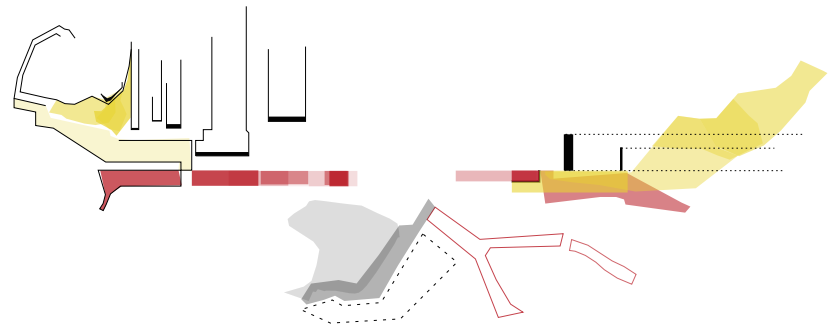
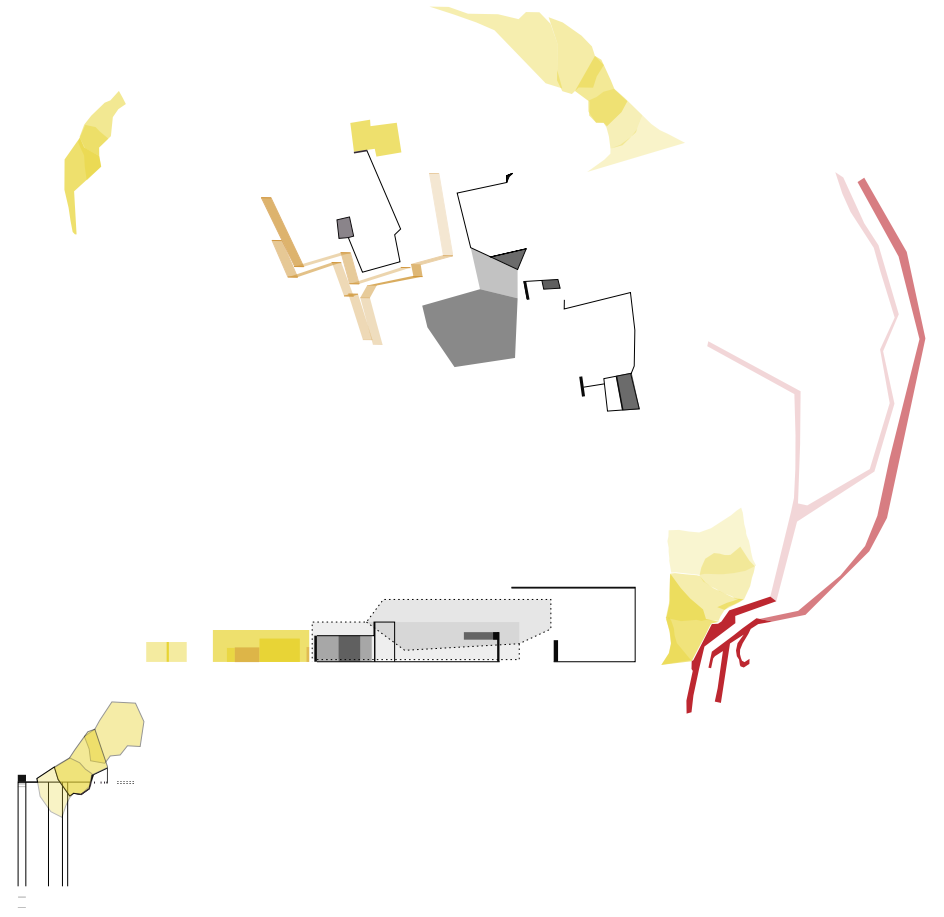

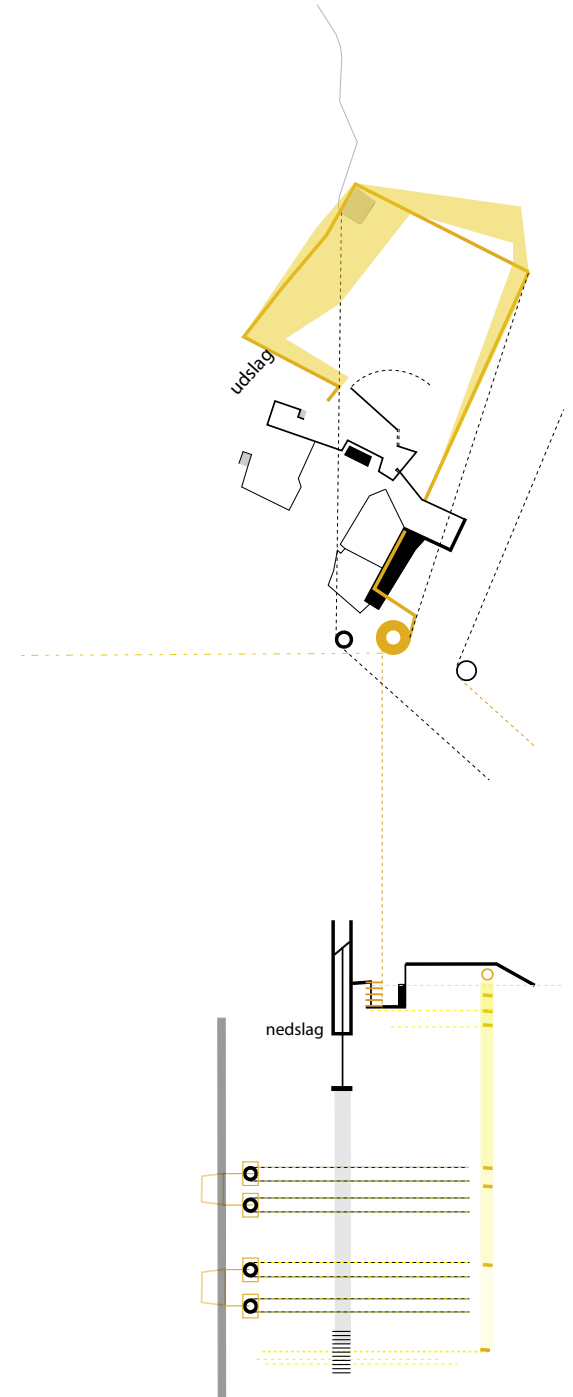

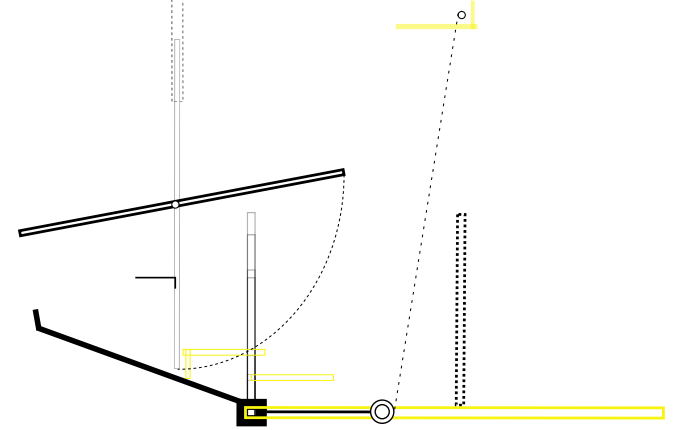
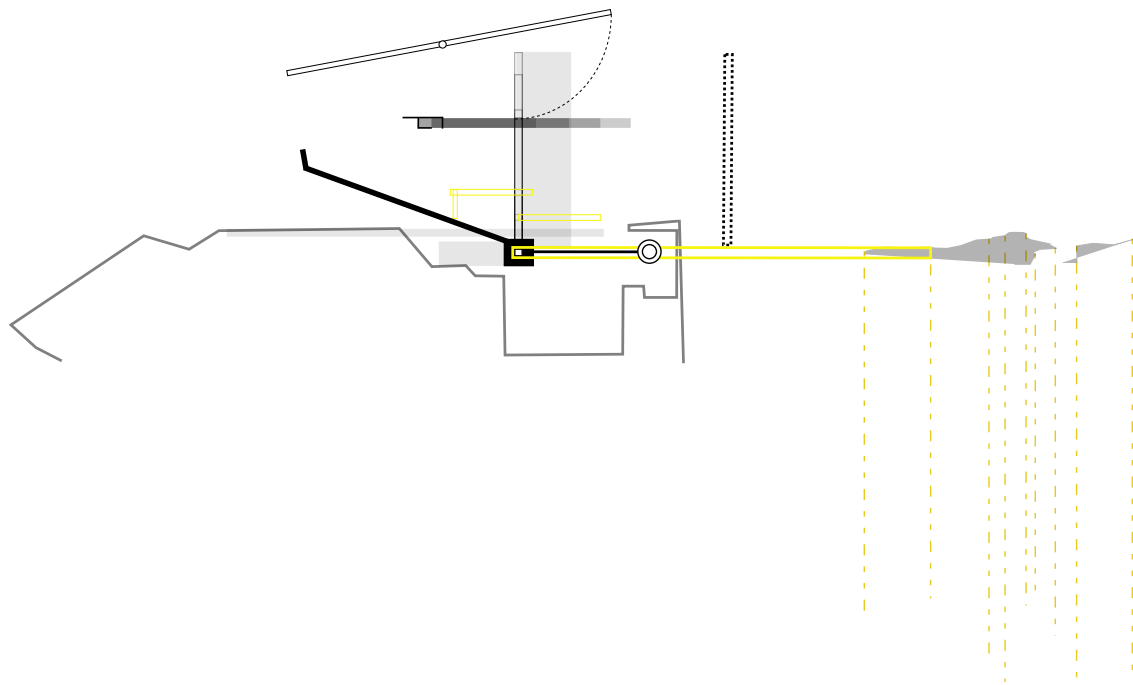
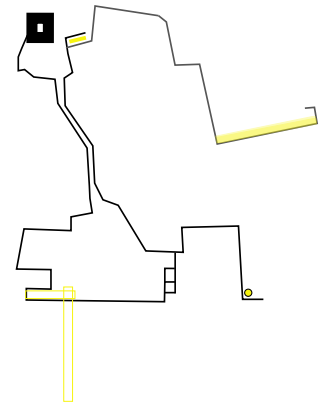
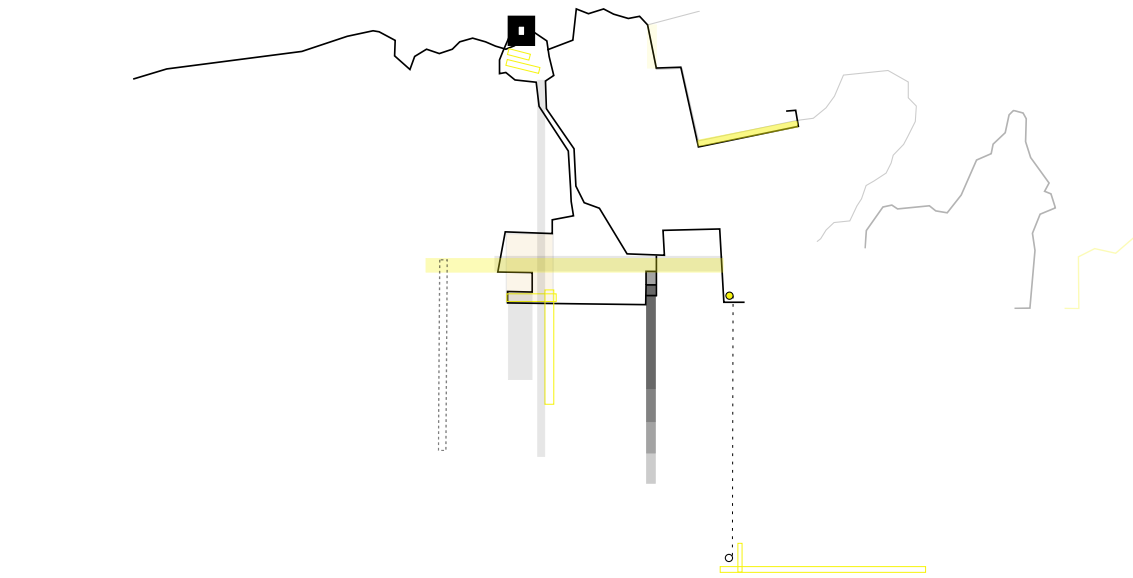

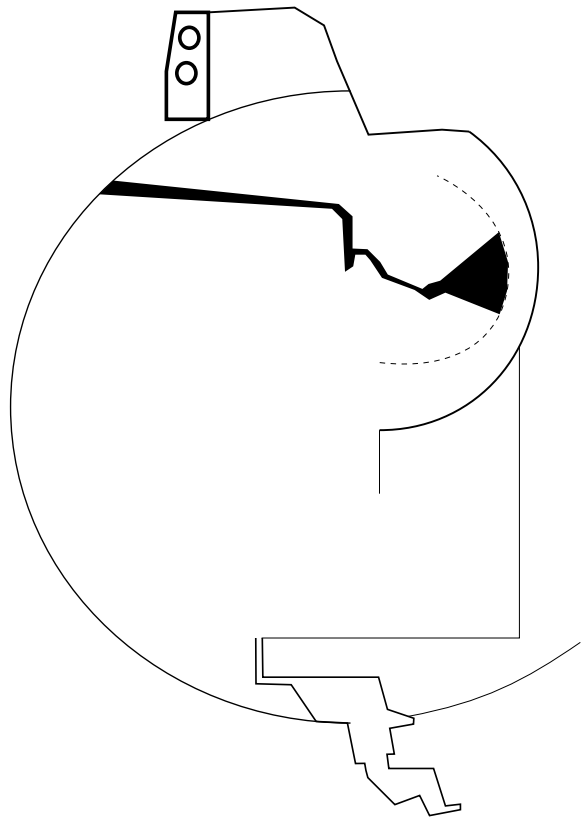

omdrejning

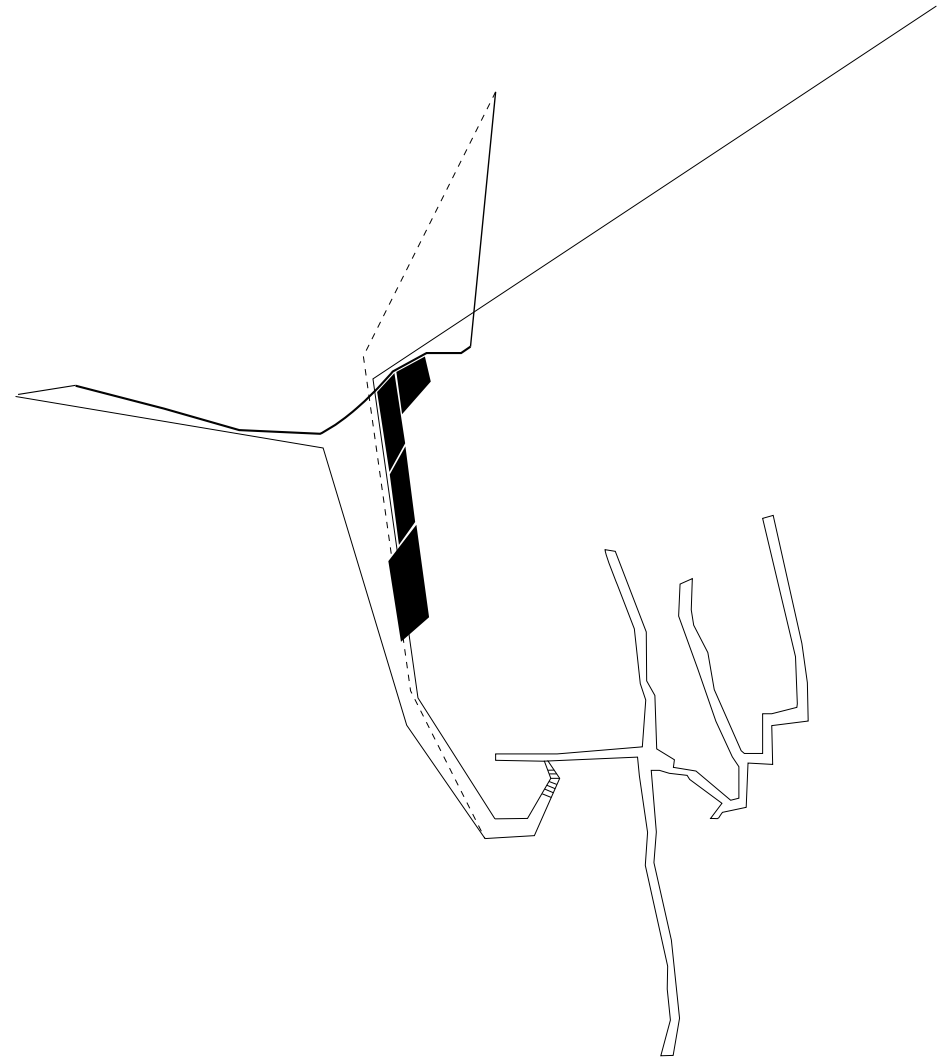

afkobling

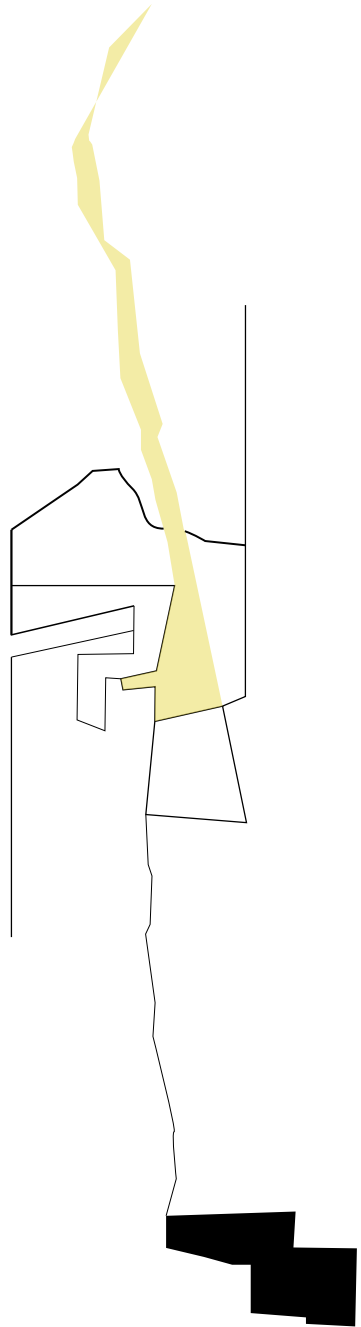

fragmentering

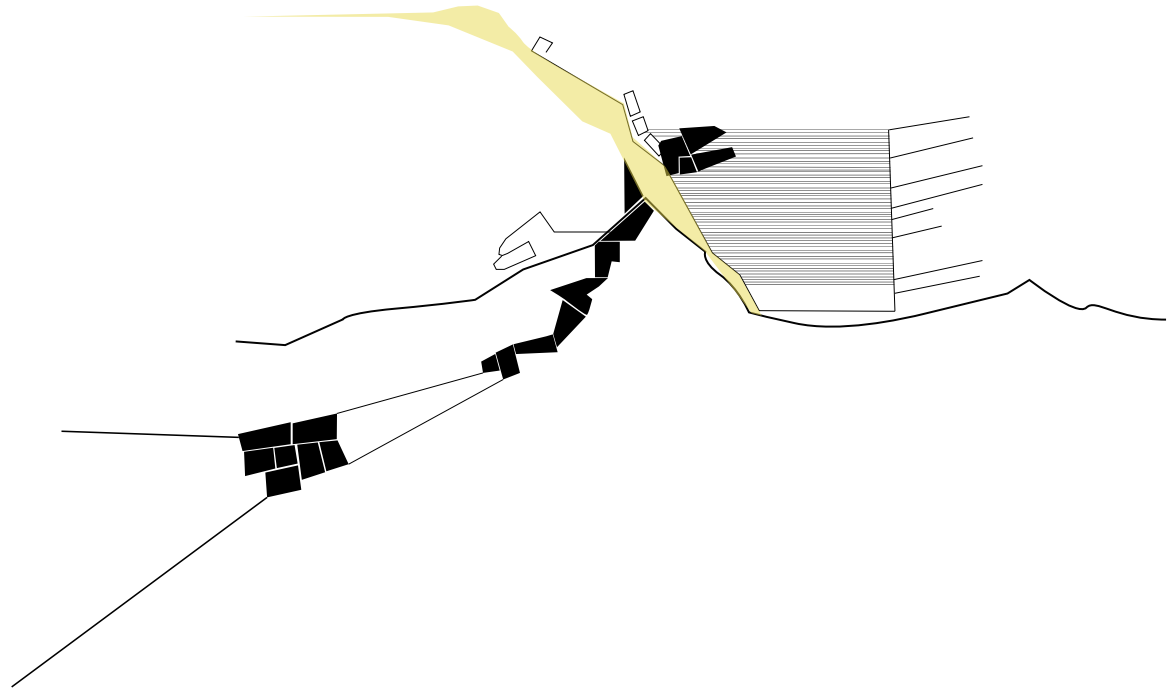

nye enheder

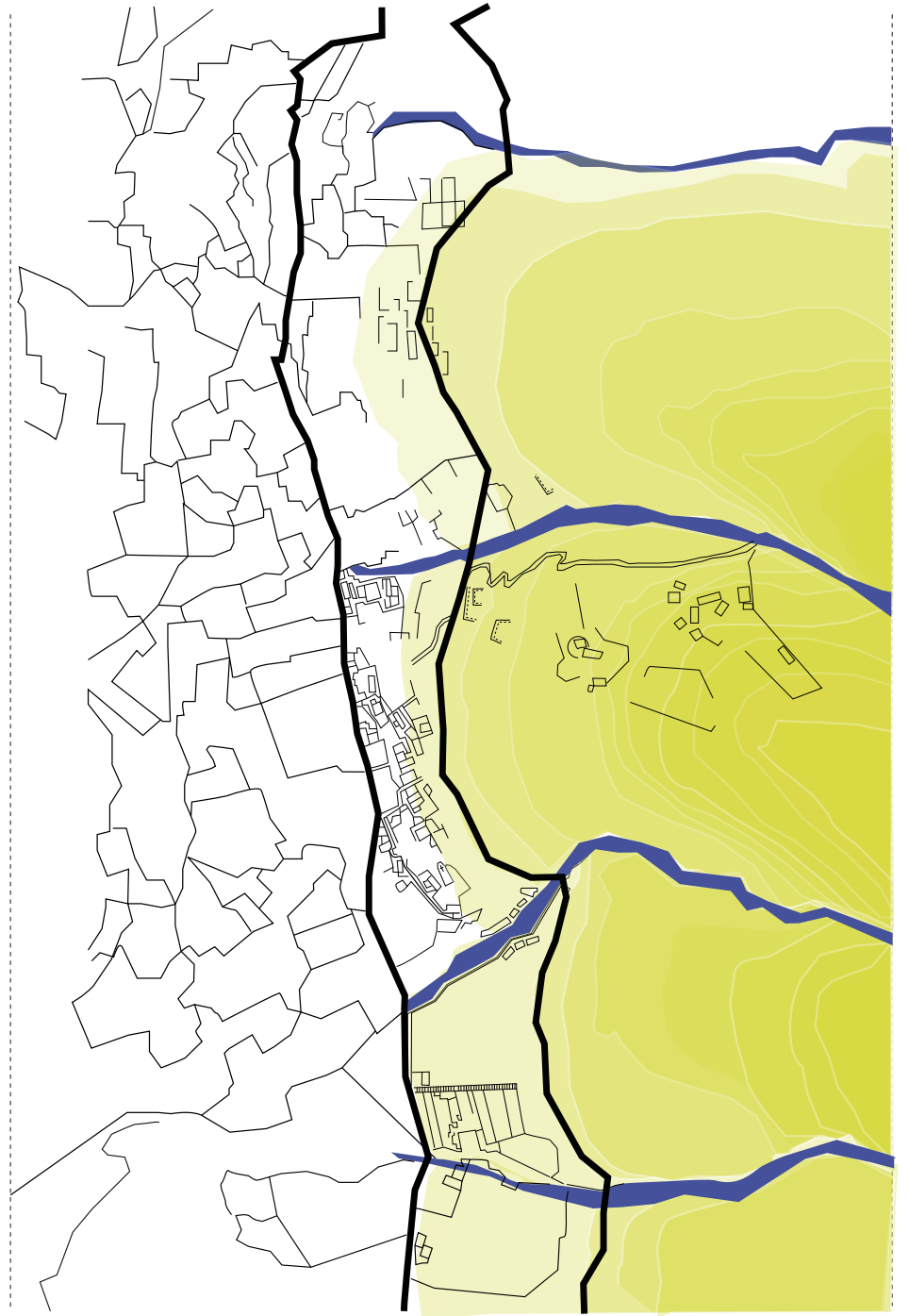

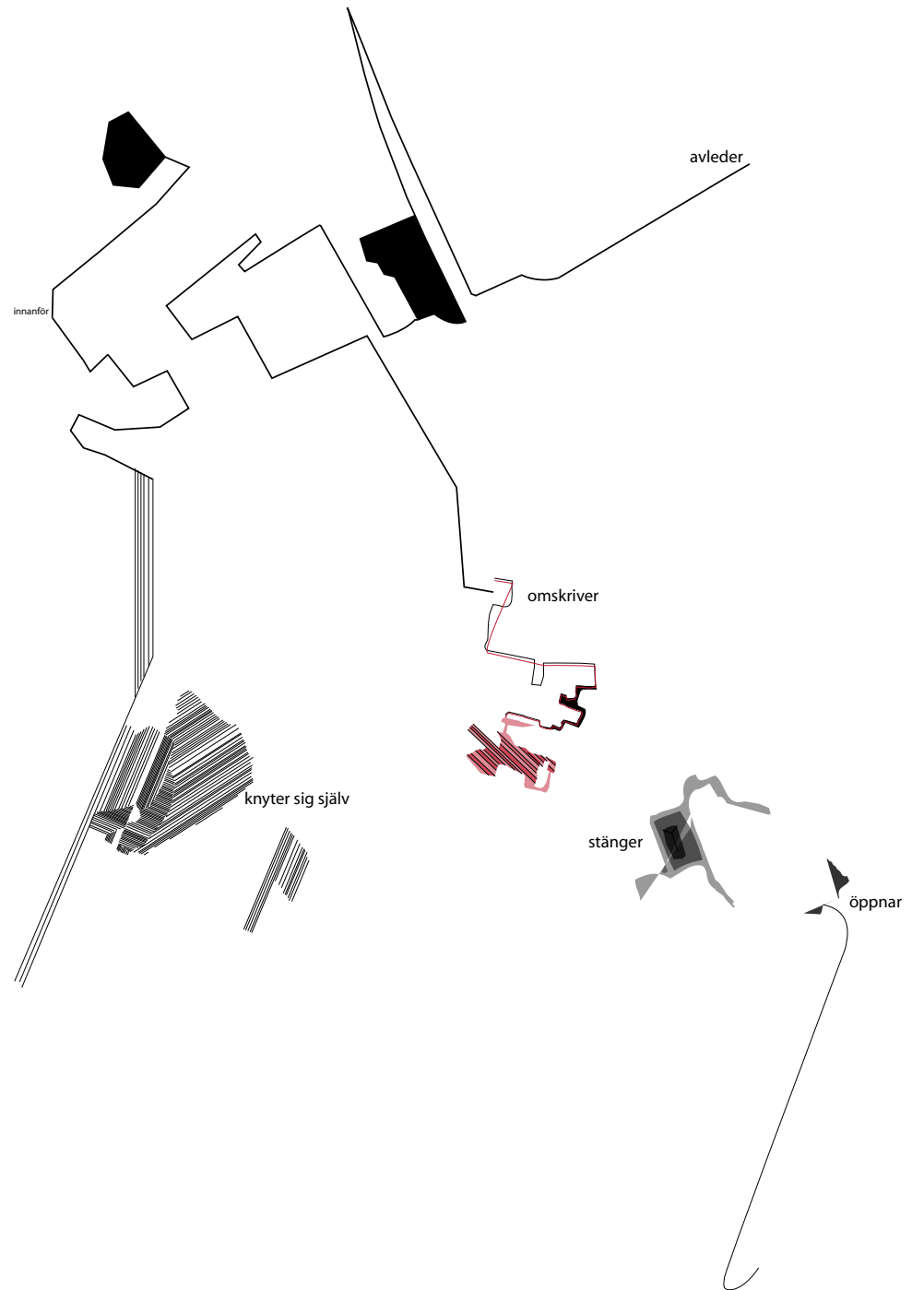

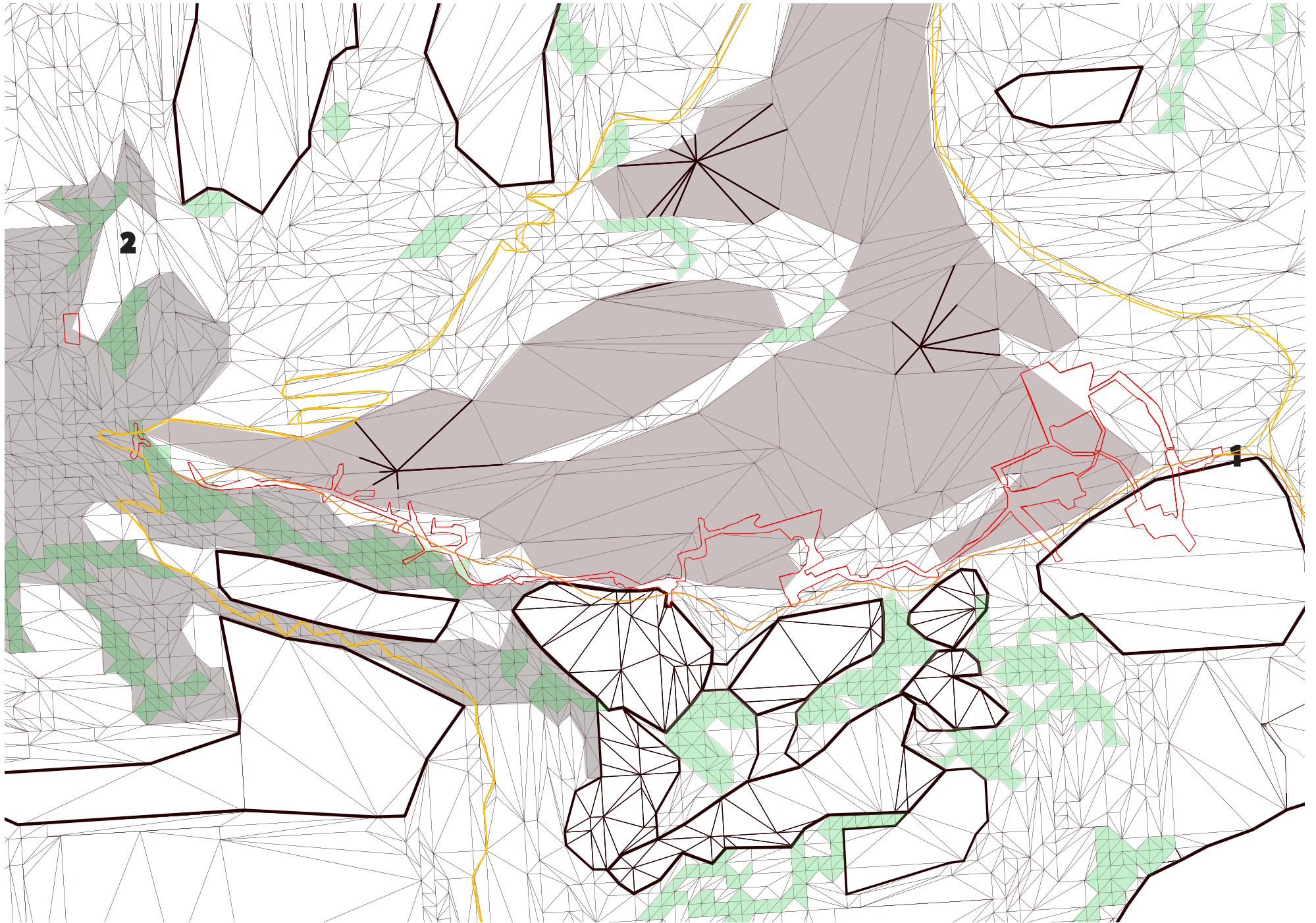

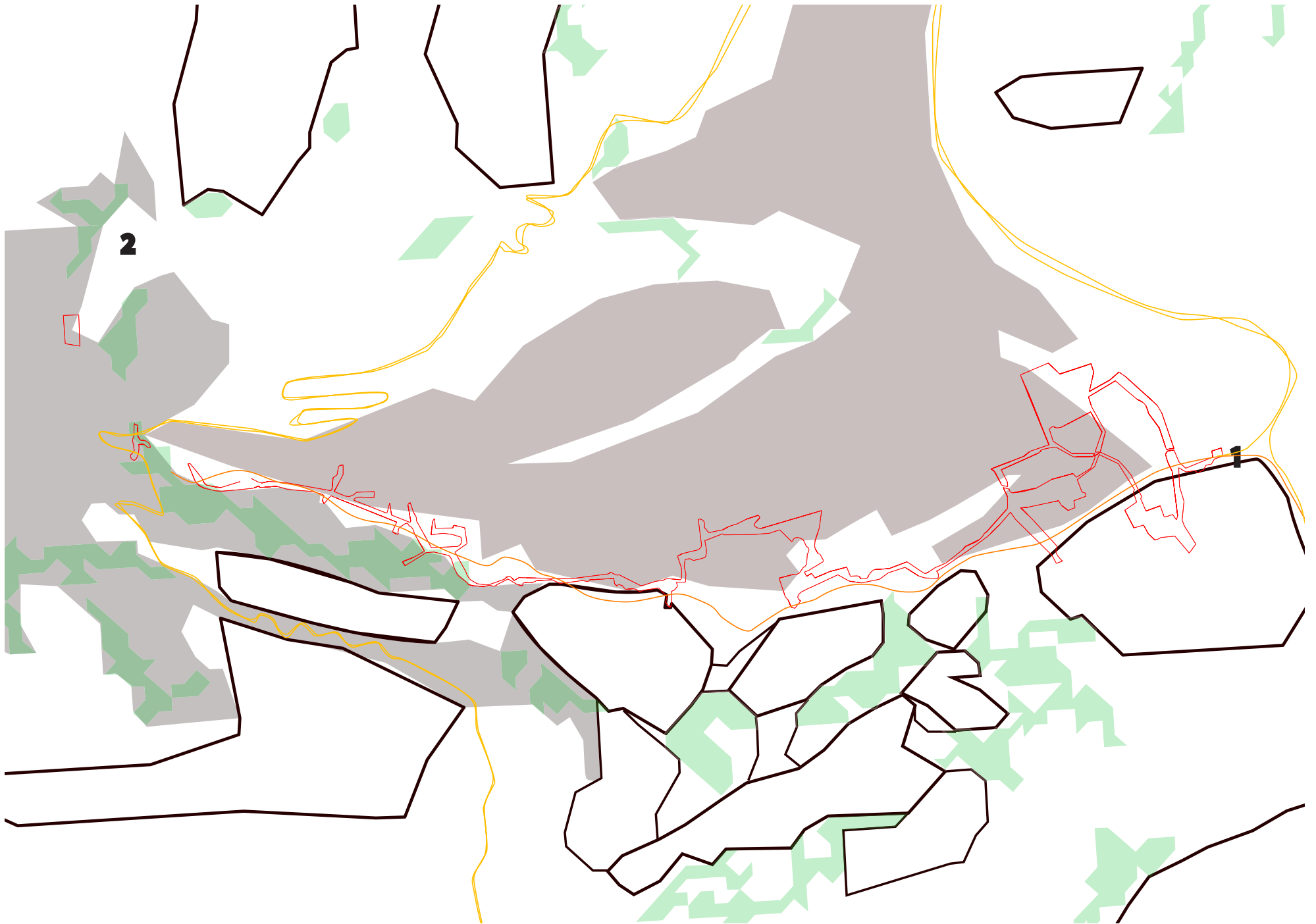

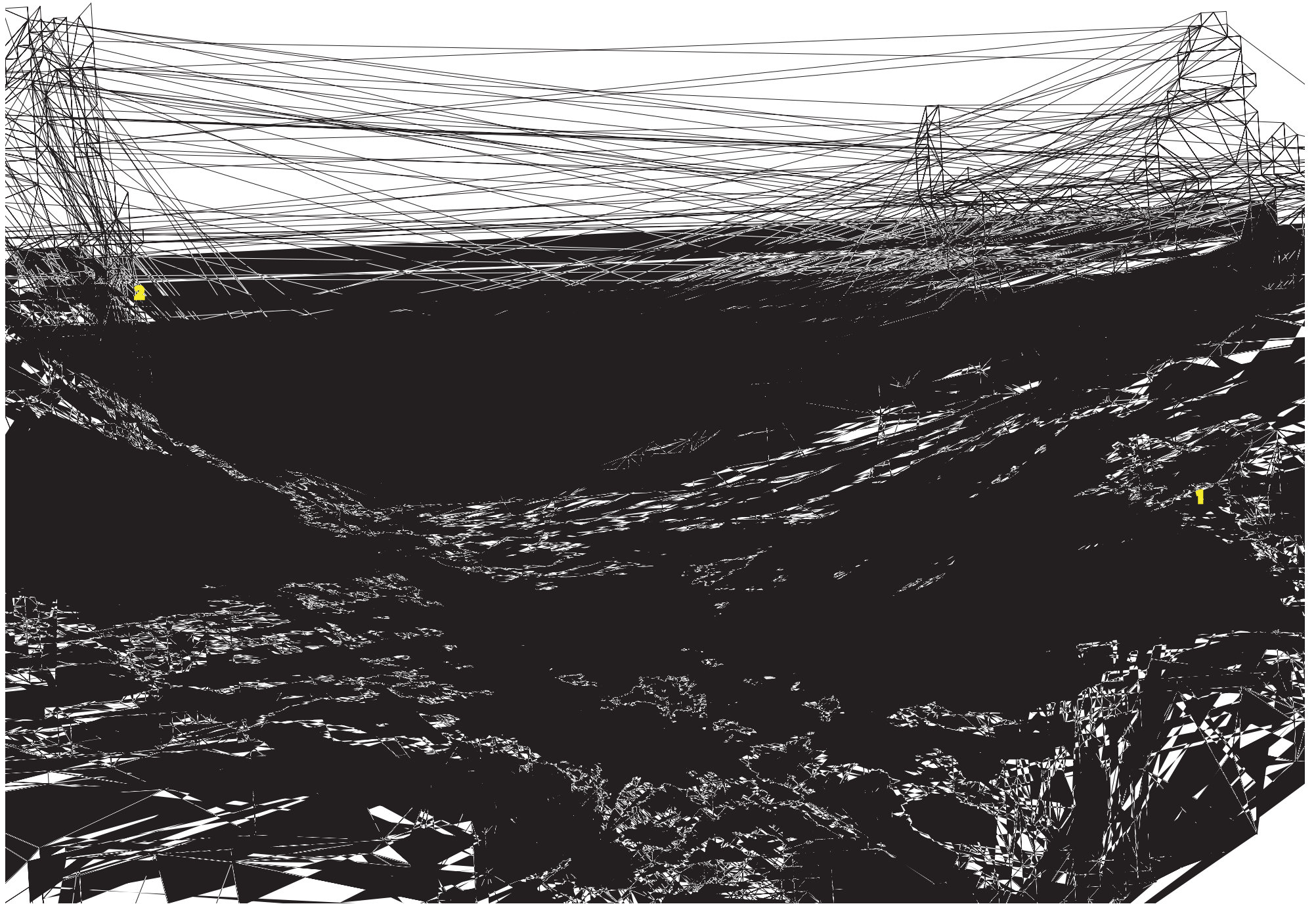

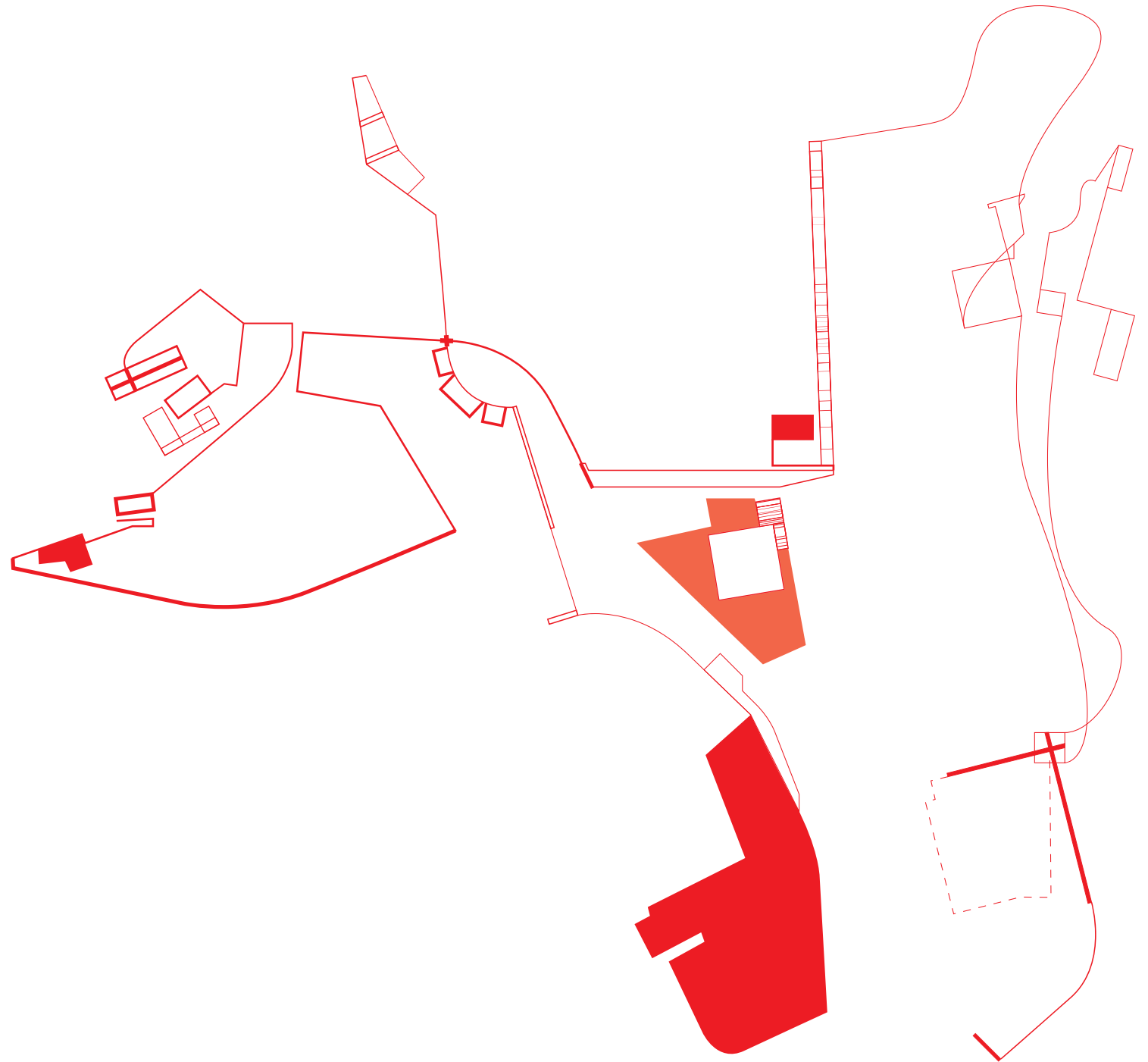

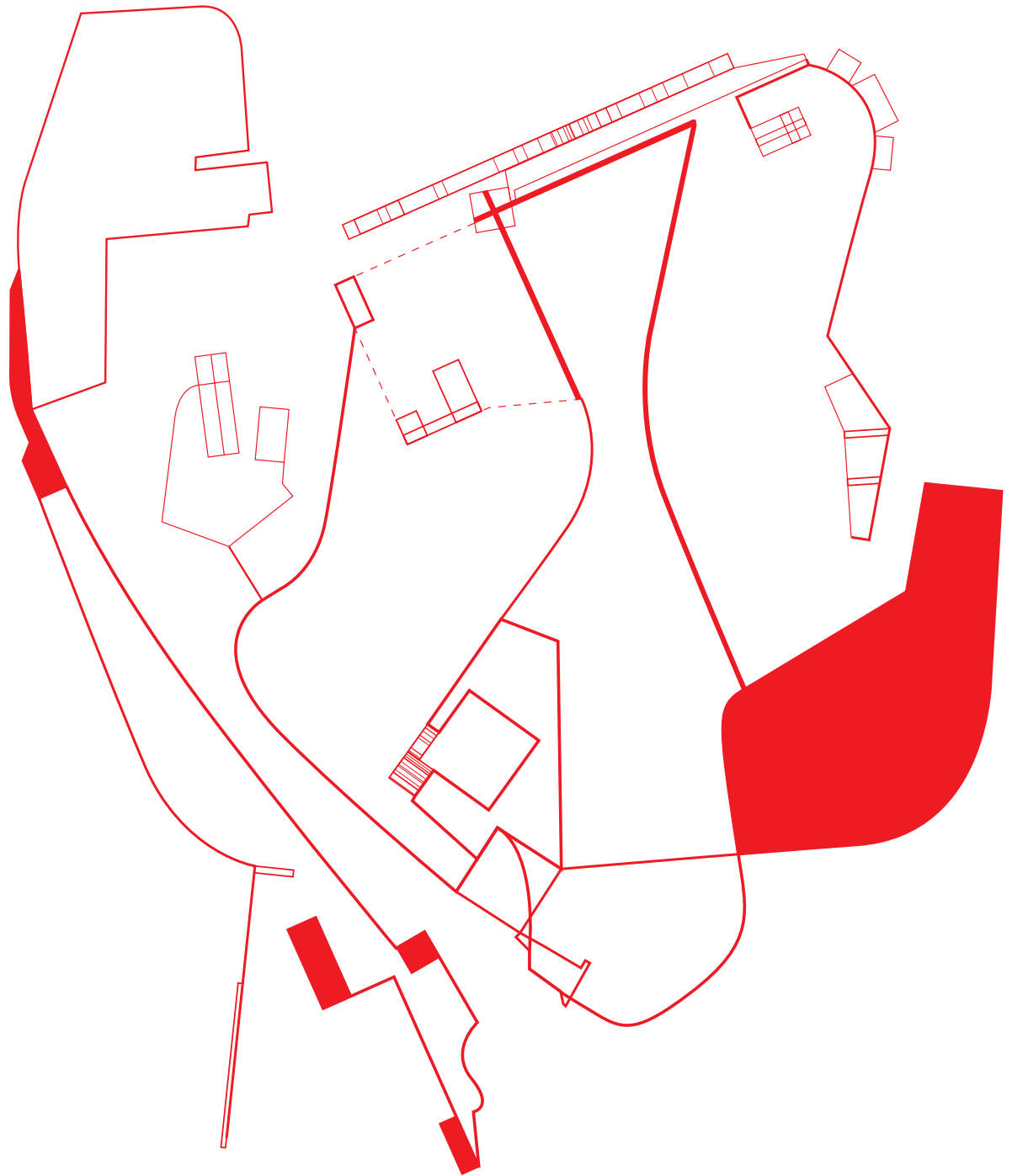



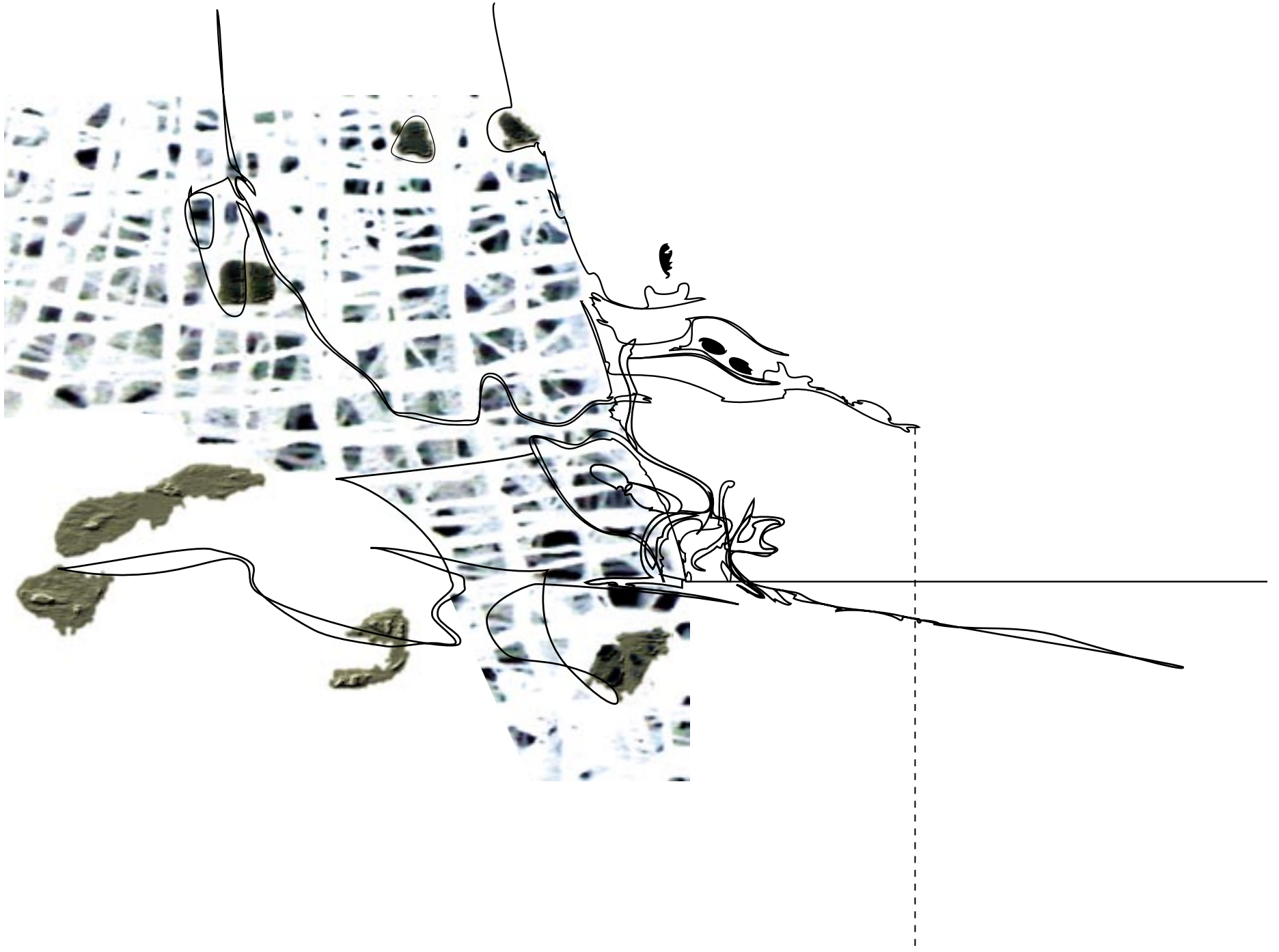

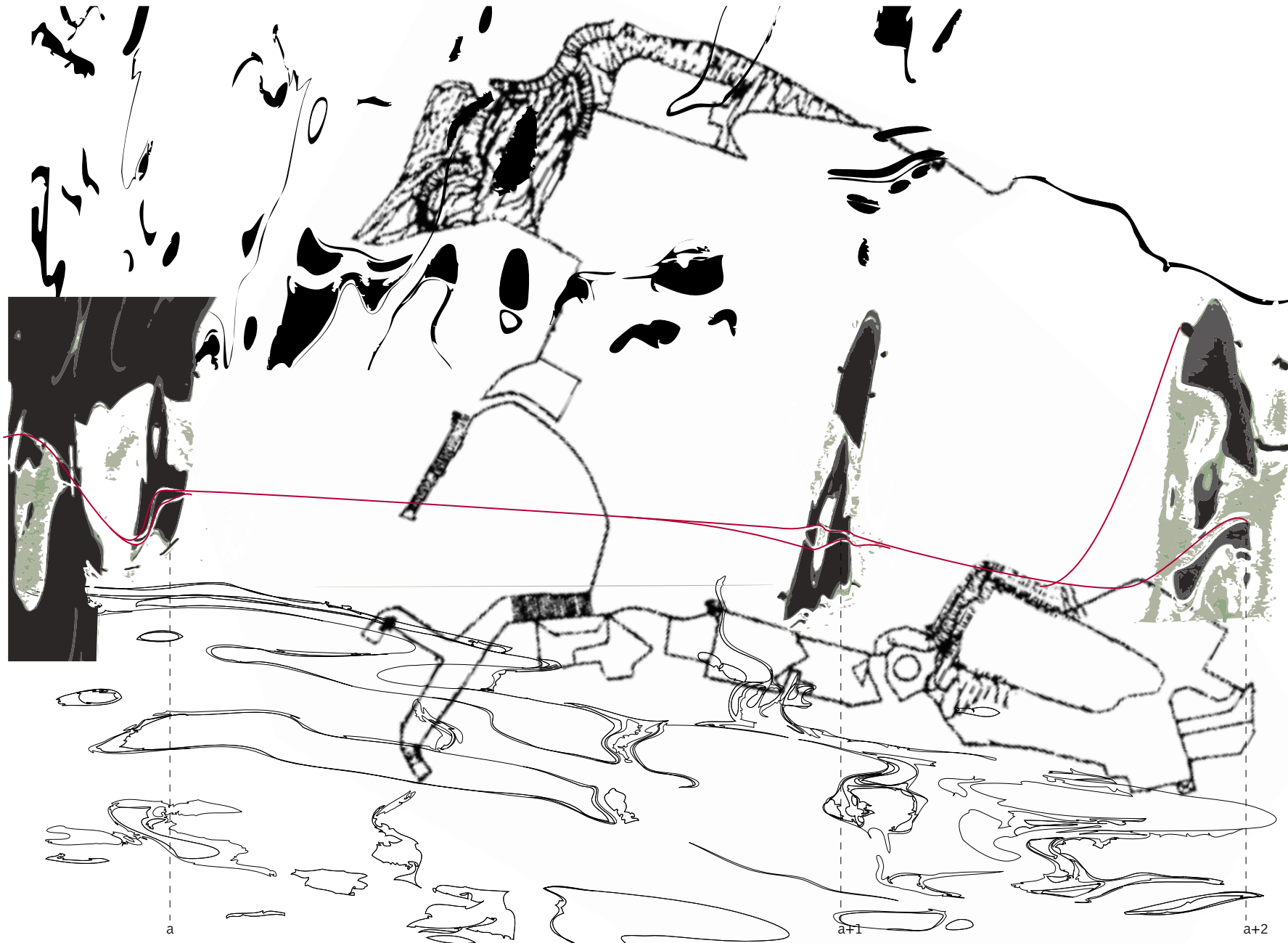

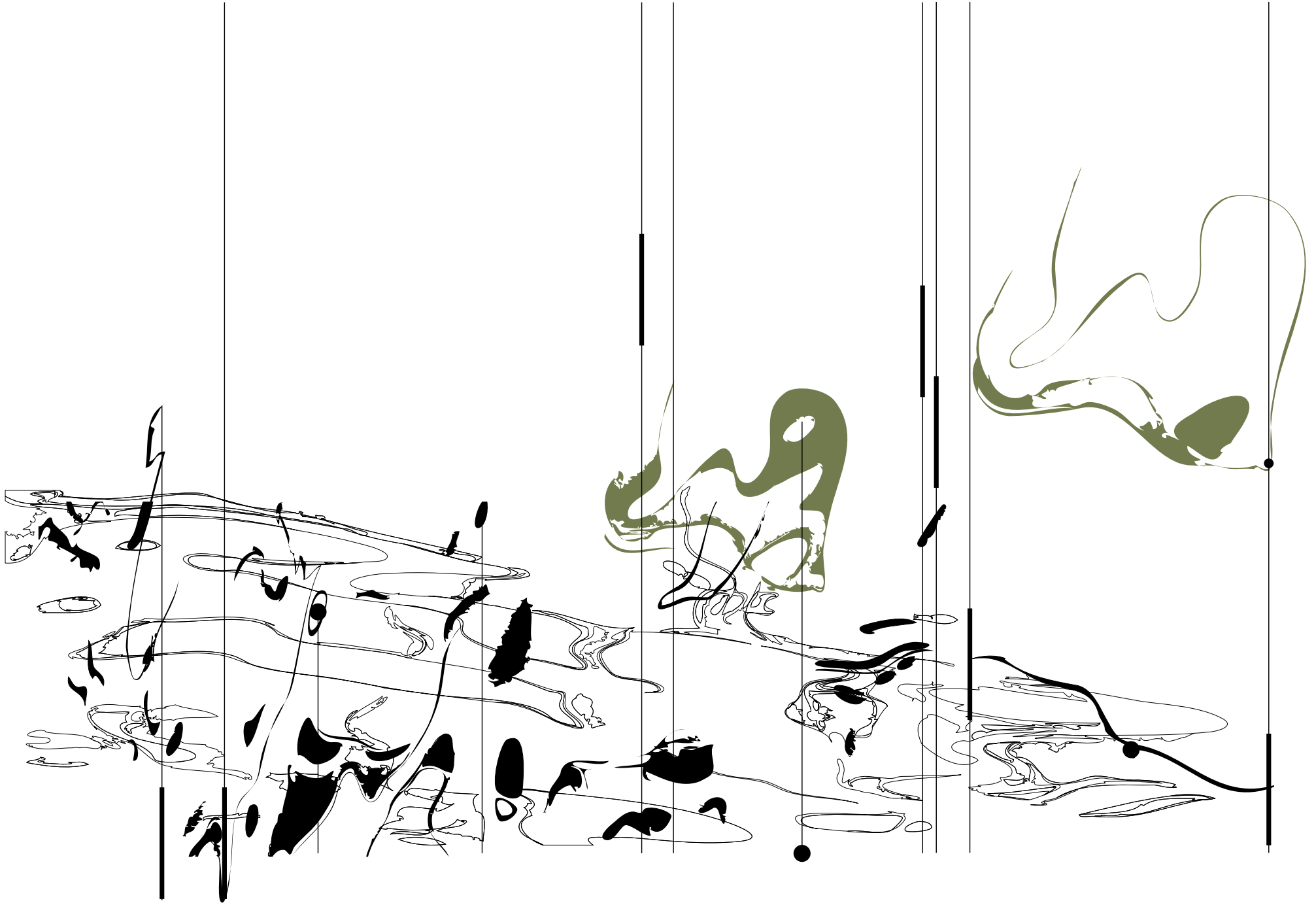

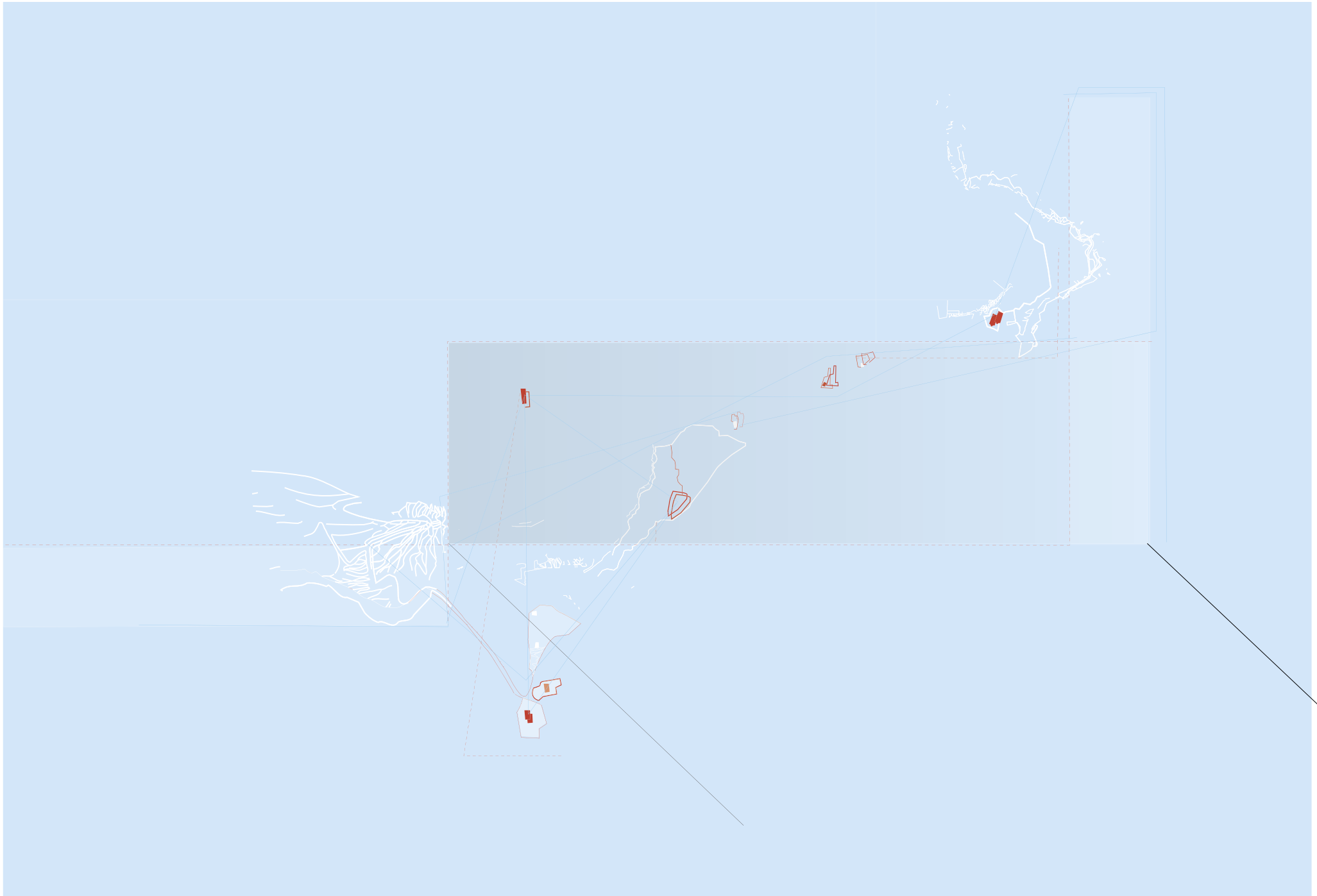

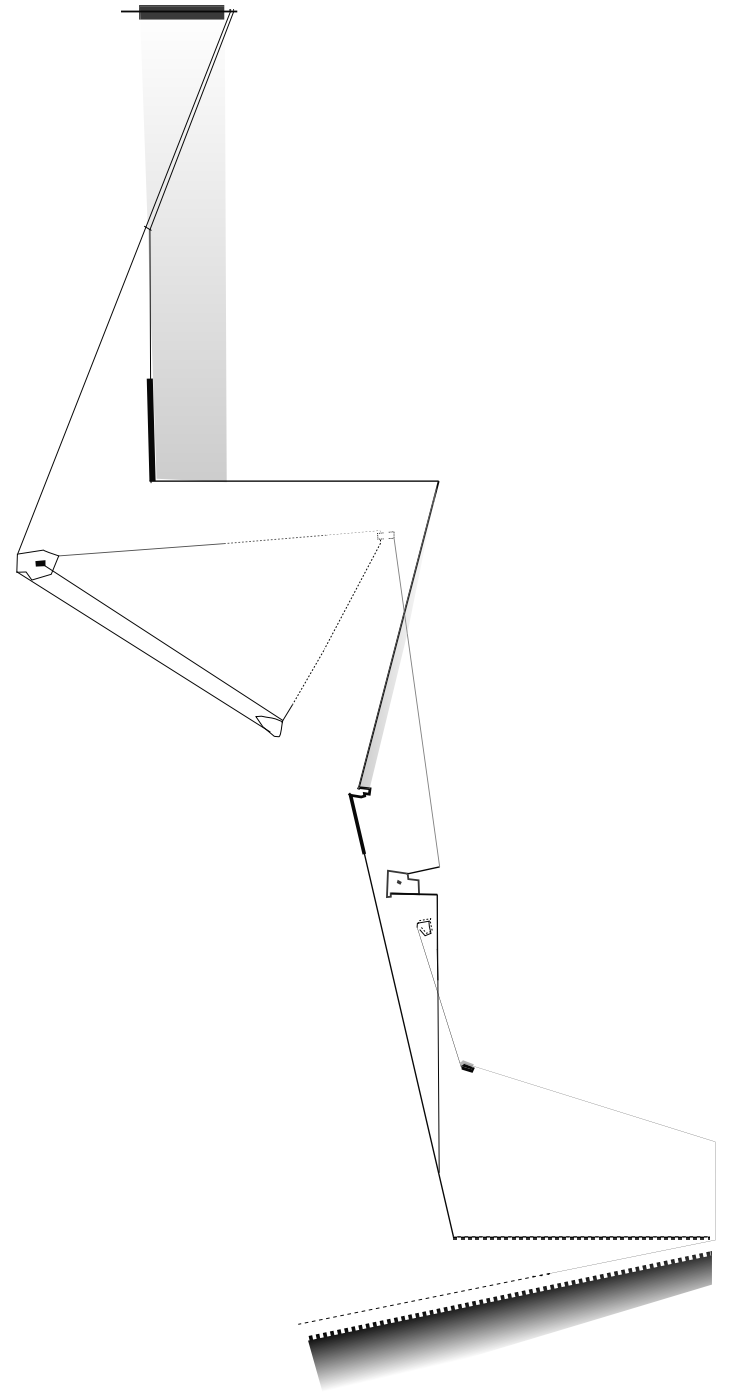

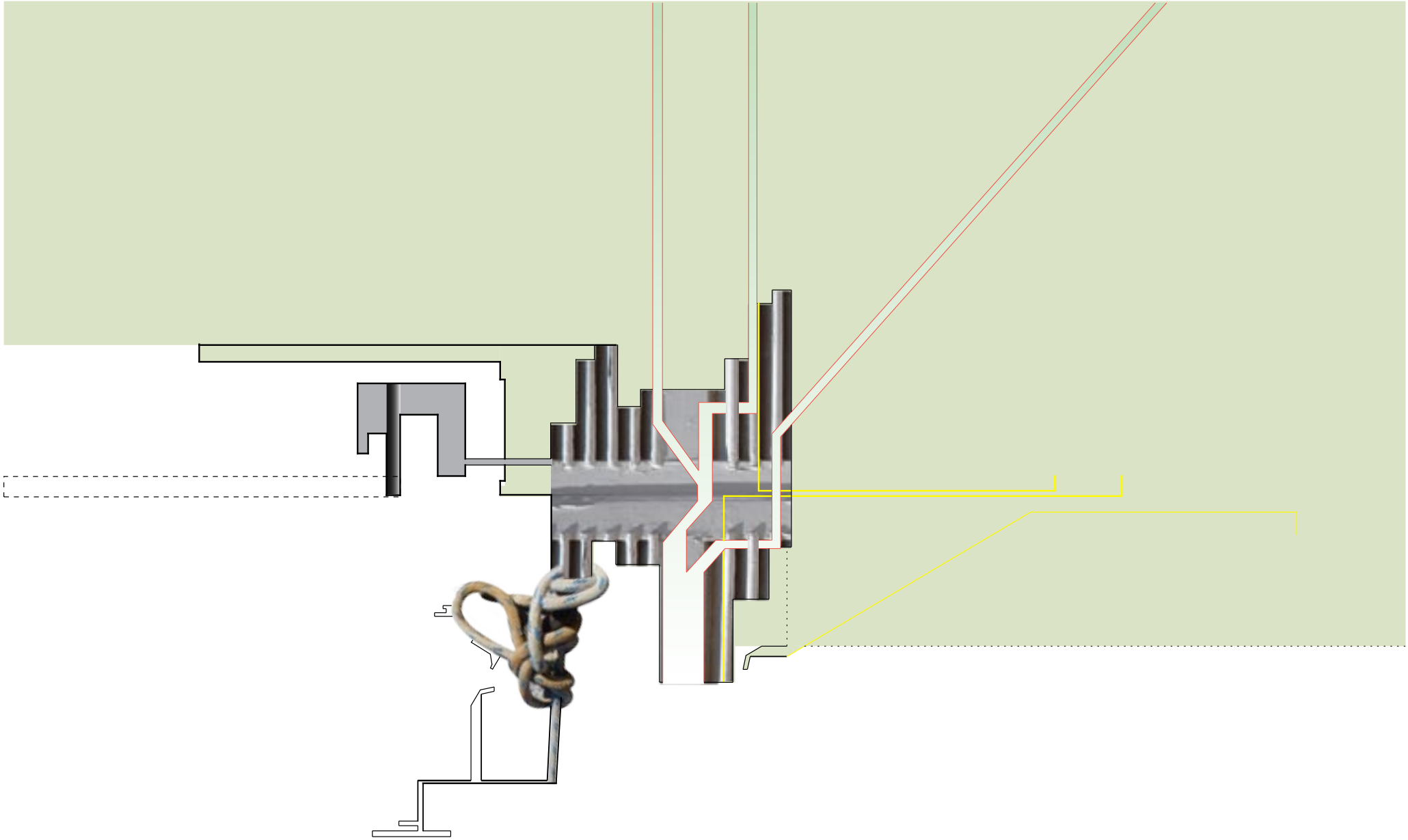

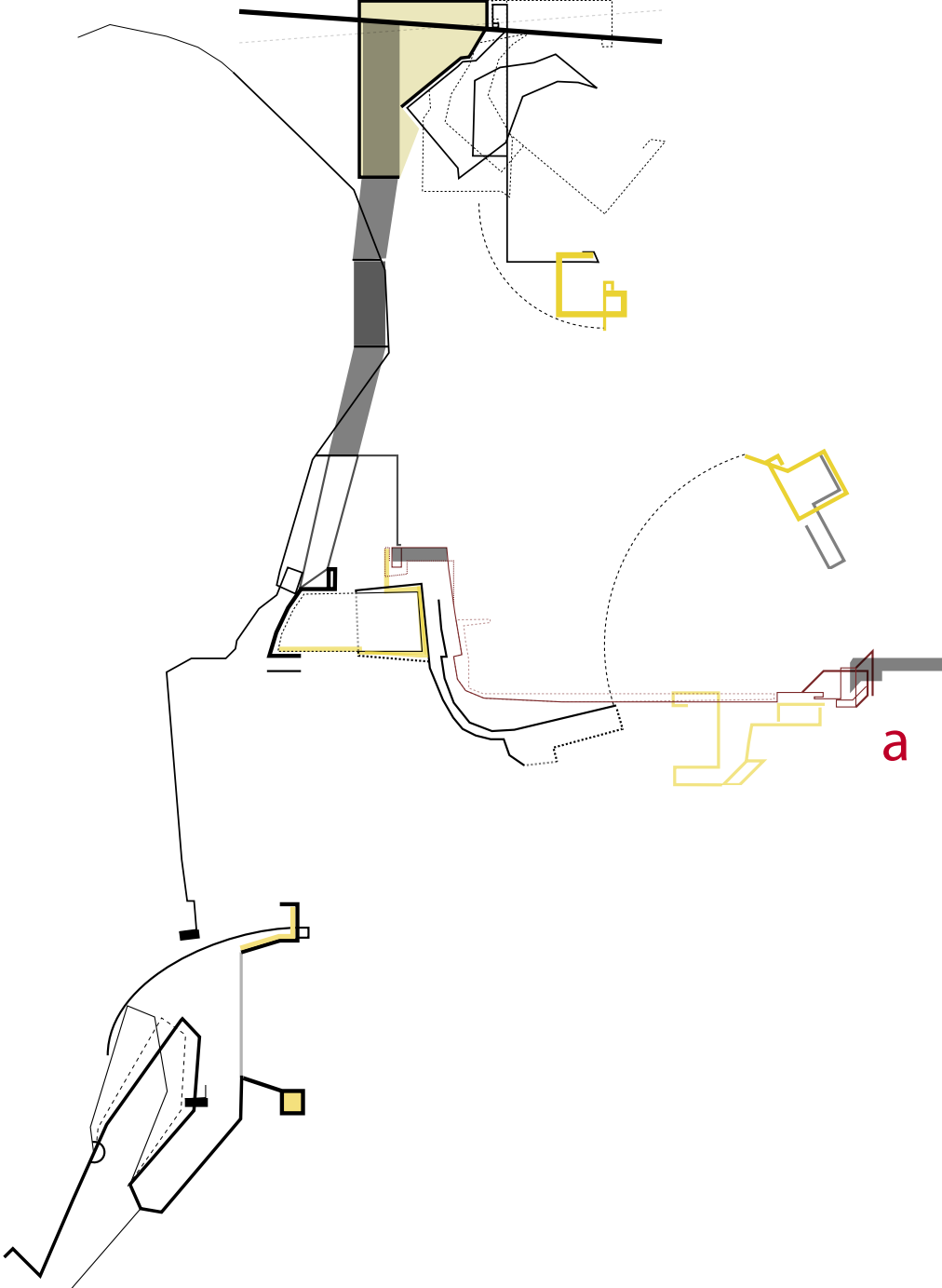

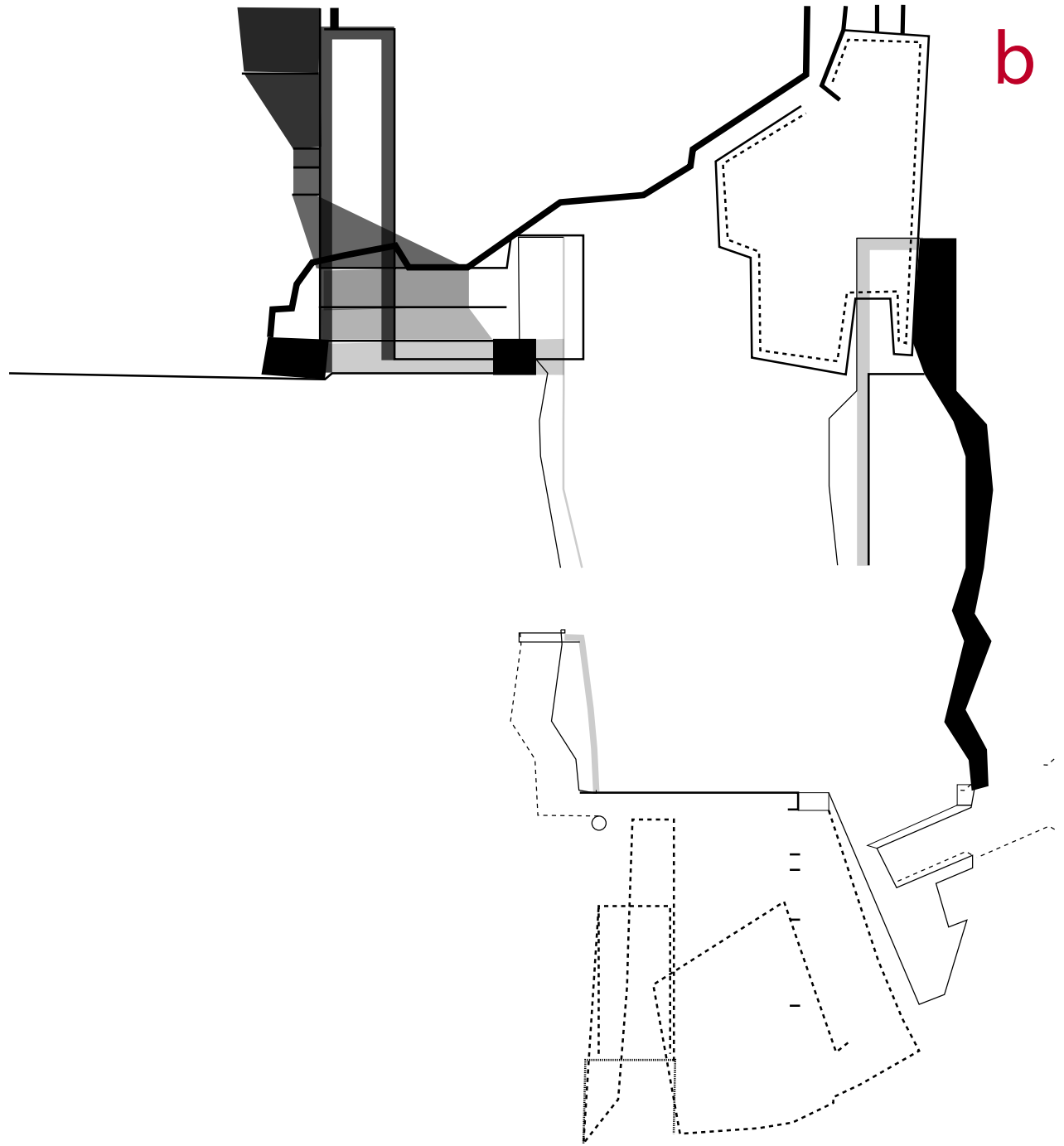

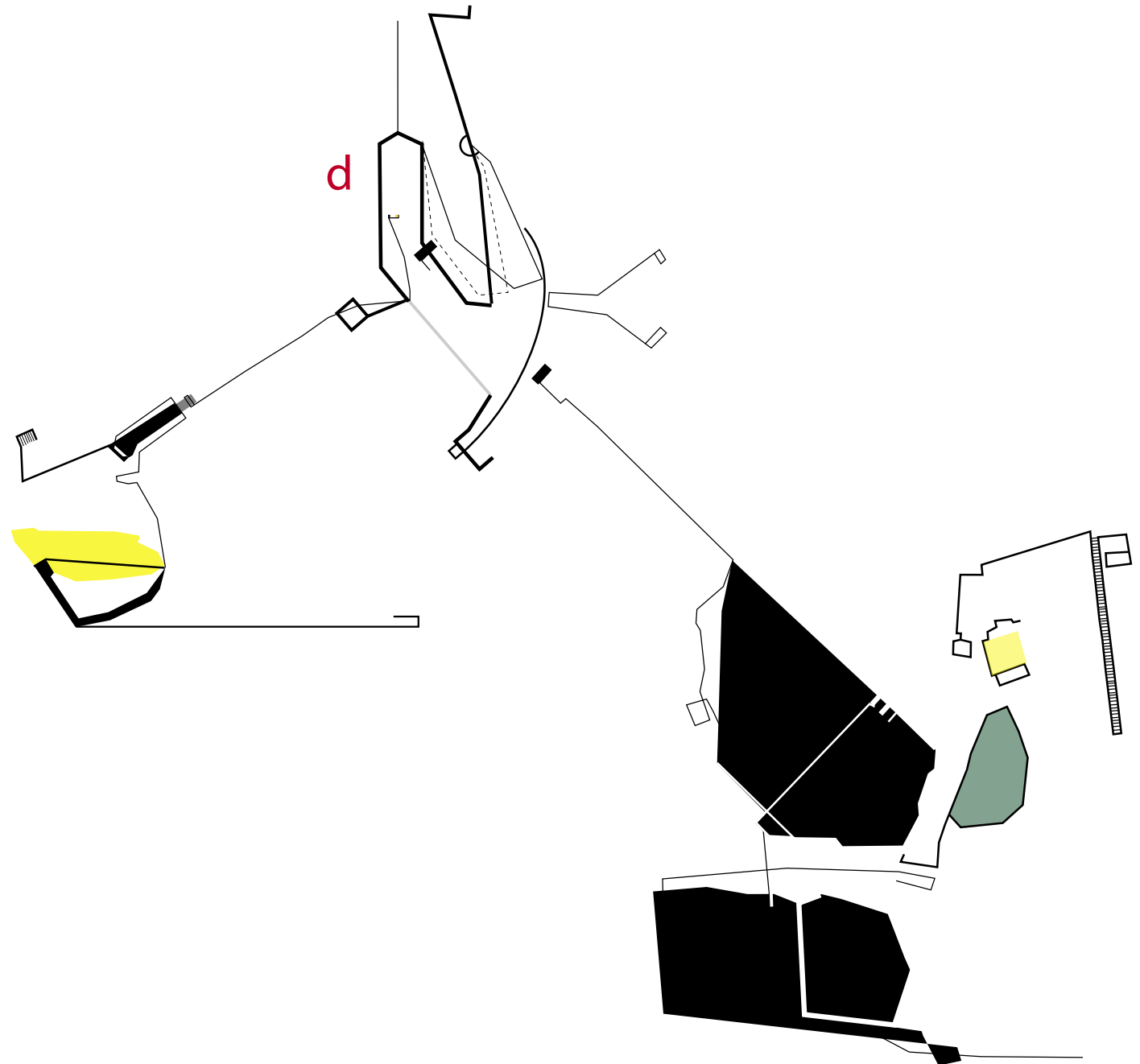

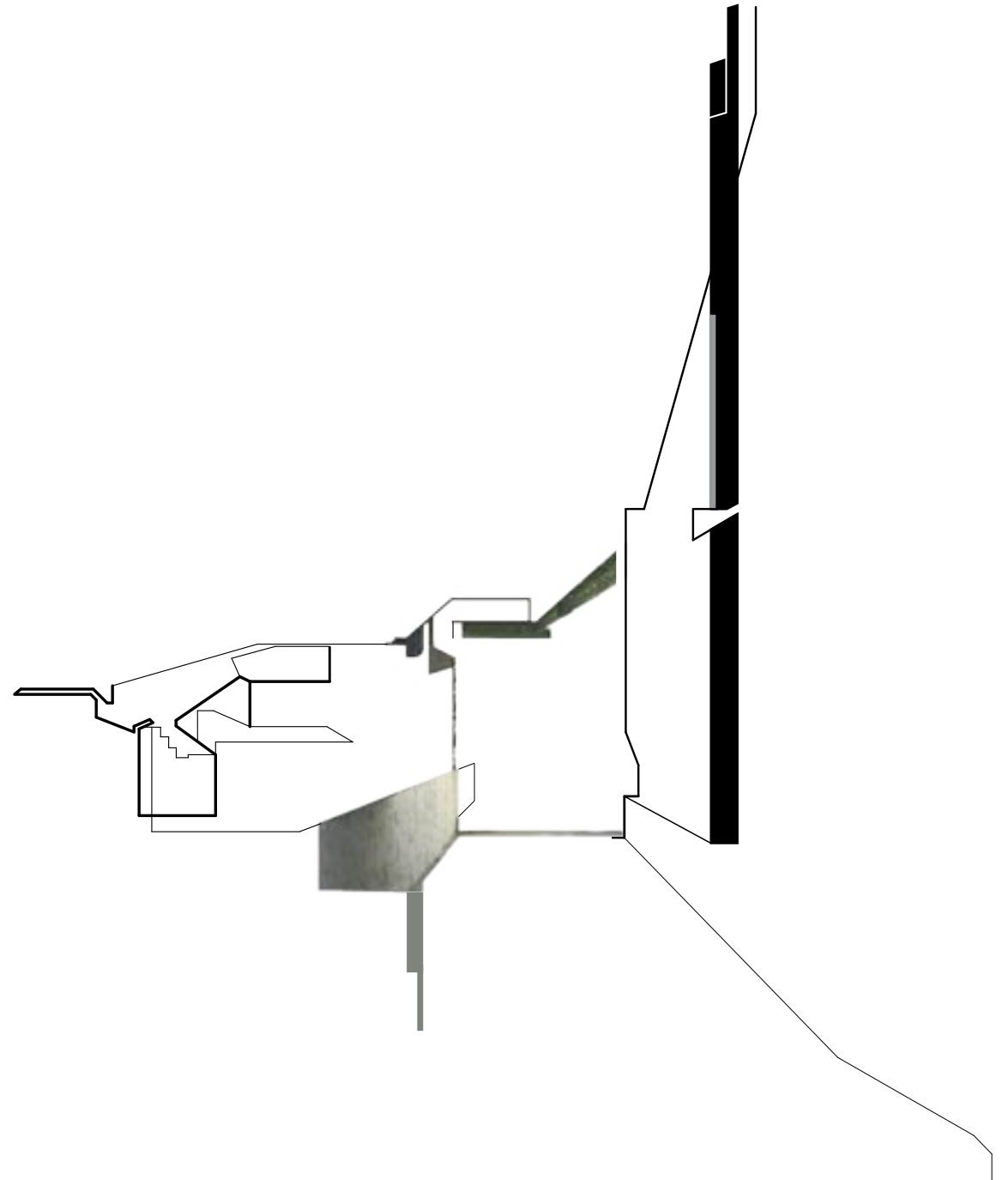

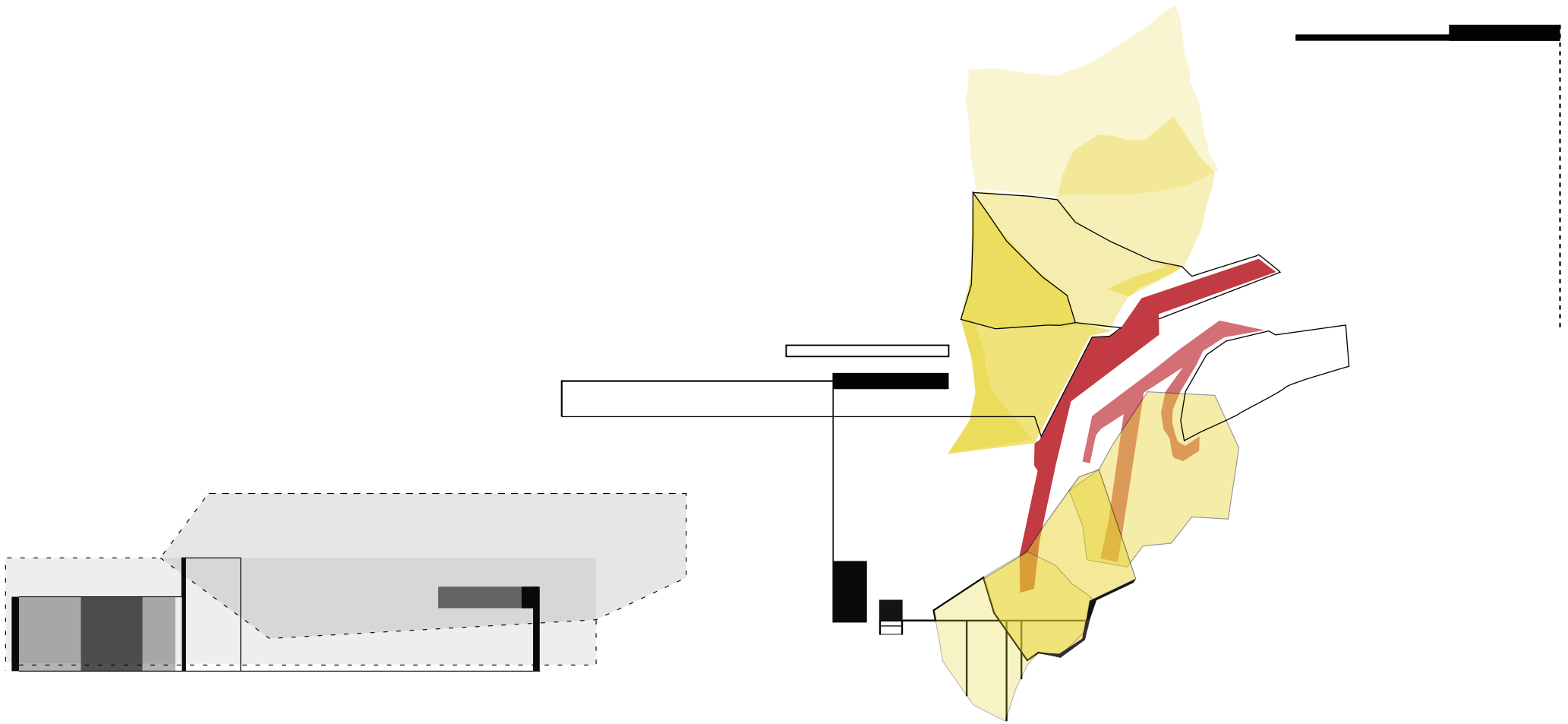

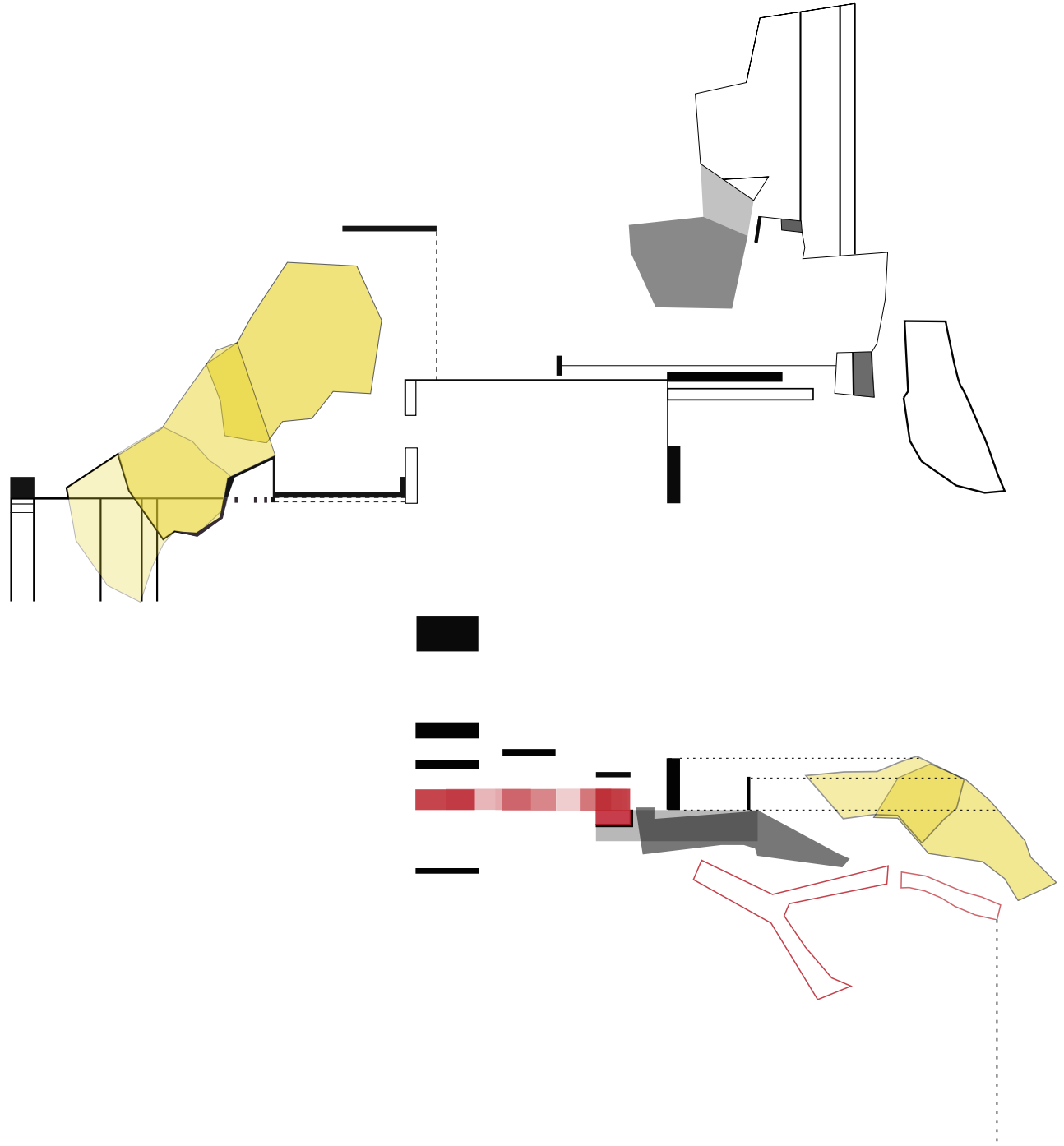

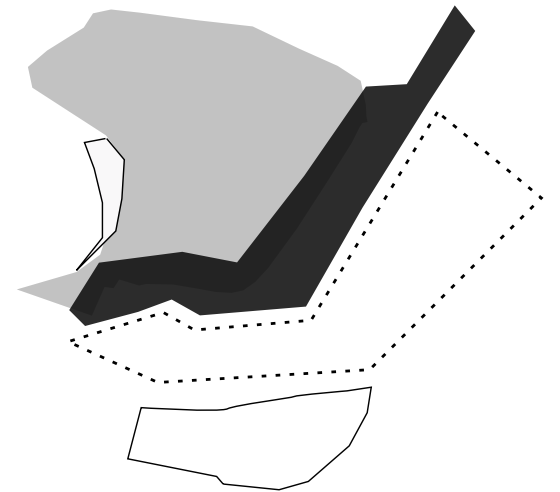
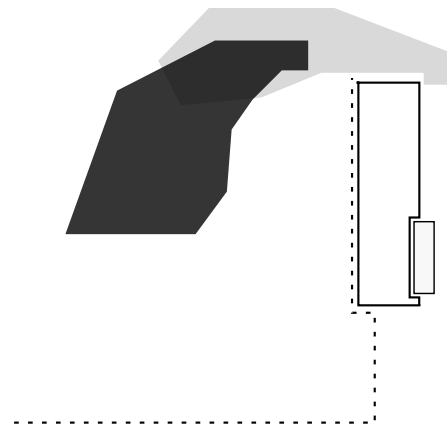
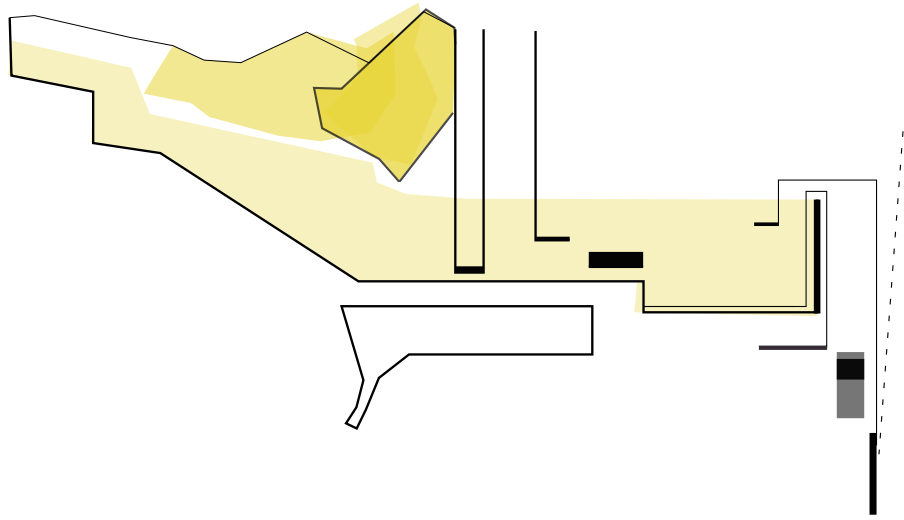

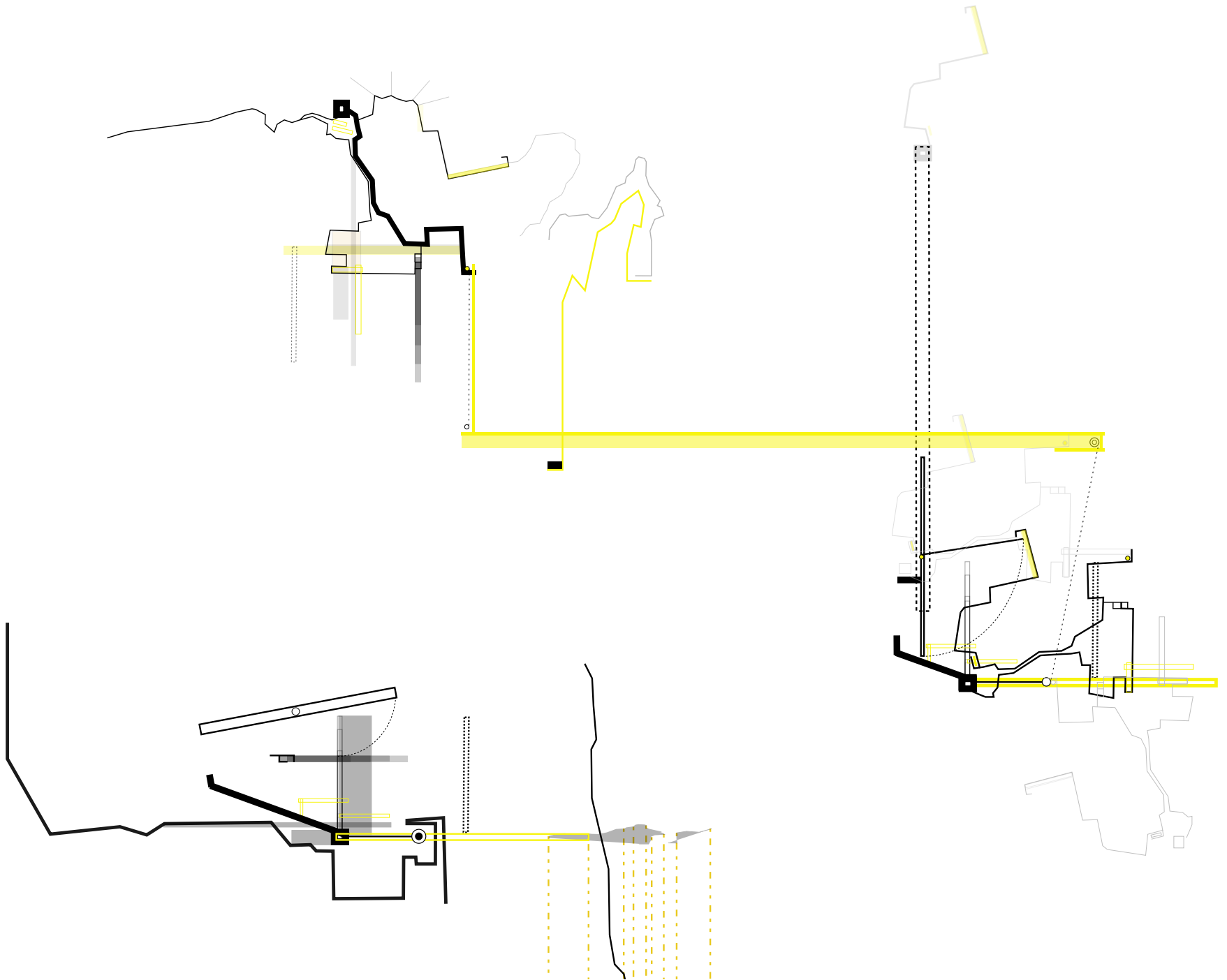

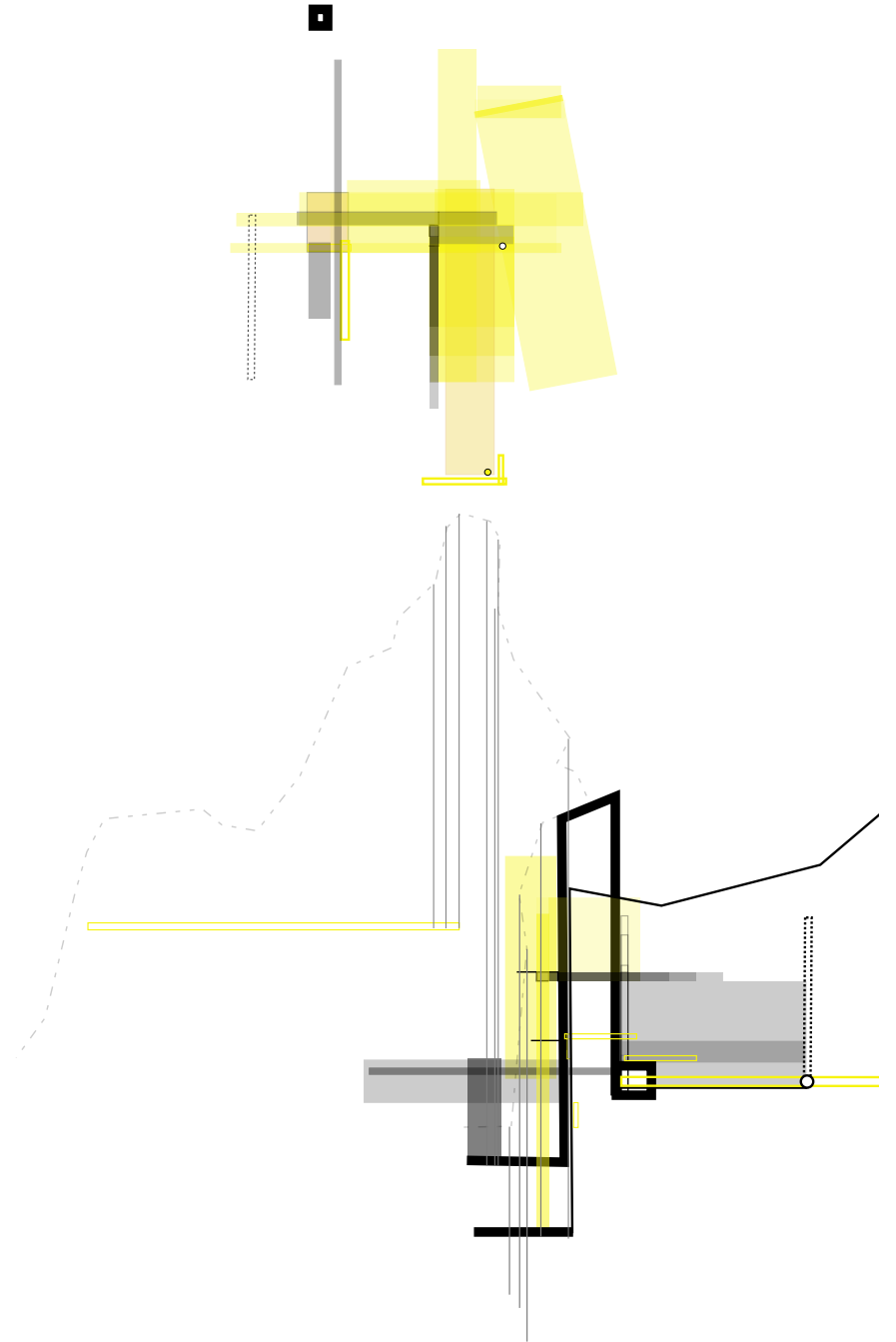
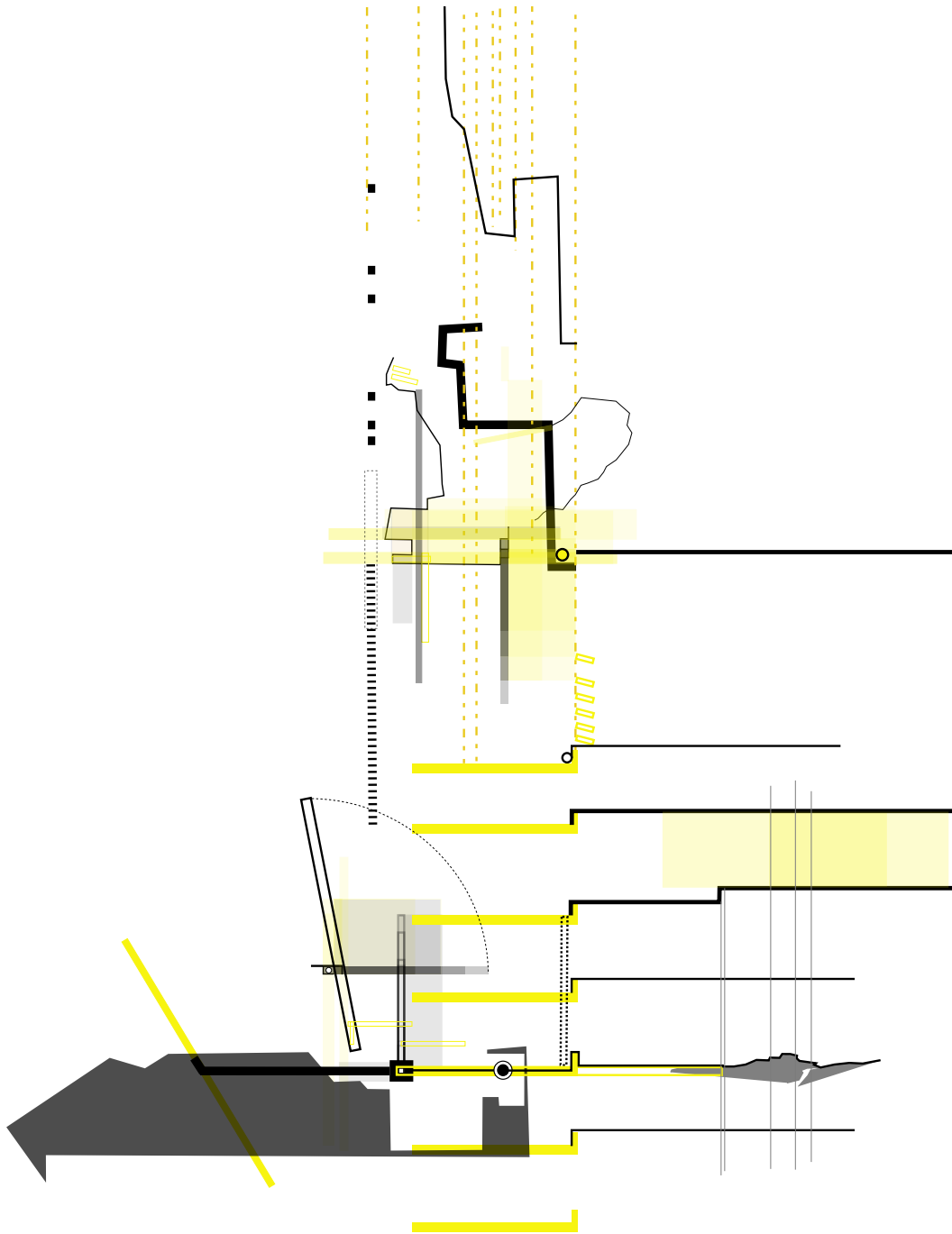

8. marts 2006

Ved at løfte materialet ud af kortet (og stryge signifiant/fortolkningen) åbnes der for forskellige skaleringer (de størrelsesmæssige sammenhænge smidiggøres) og de beskrevne tilstande kan tildeles forskellige "virkemåder" alt efter, hvorledes de indgår i konstruktionen, dvs. at der kan tænkes i udspændte situationer og i komprimerede situationer på en gang: del og helhed erstattes af en bevægelse i tilstanden og hvor intensiteterne skaber konstante nye sammenhænge og kredsløb.

En række generelle spørgsmål til materialet omkring de beskrevne tilstande:

- Beskriv relationer i forløb med skiftende hændelser: - træk en række linier der konstruerer et forløb af topologiske former - skab territorier og deterritorialiseringer – opløse og sammensæt intensitetsgrupperinger.
- Beskriv gennem de grafiske notationer en række ombytninger af forskellige vægtninger og gør bevægelserne flydende, facetterede, etc. – skab overgange, tærskler.
- Beskriv funktionsmåder og gør nogle konstruktioner synlige – skab uophørlige bevægelser.

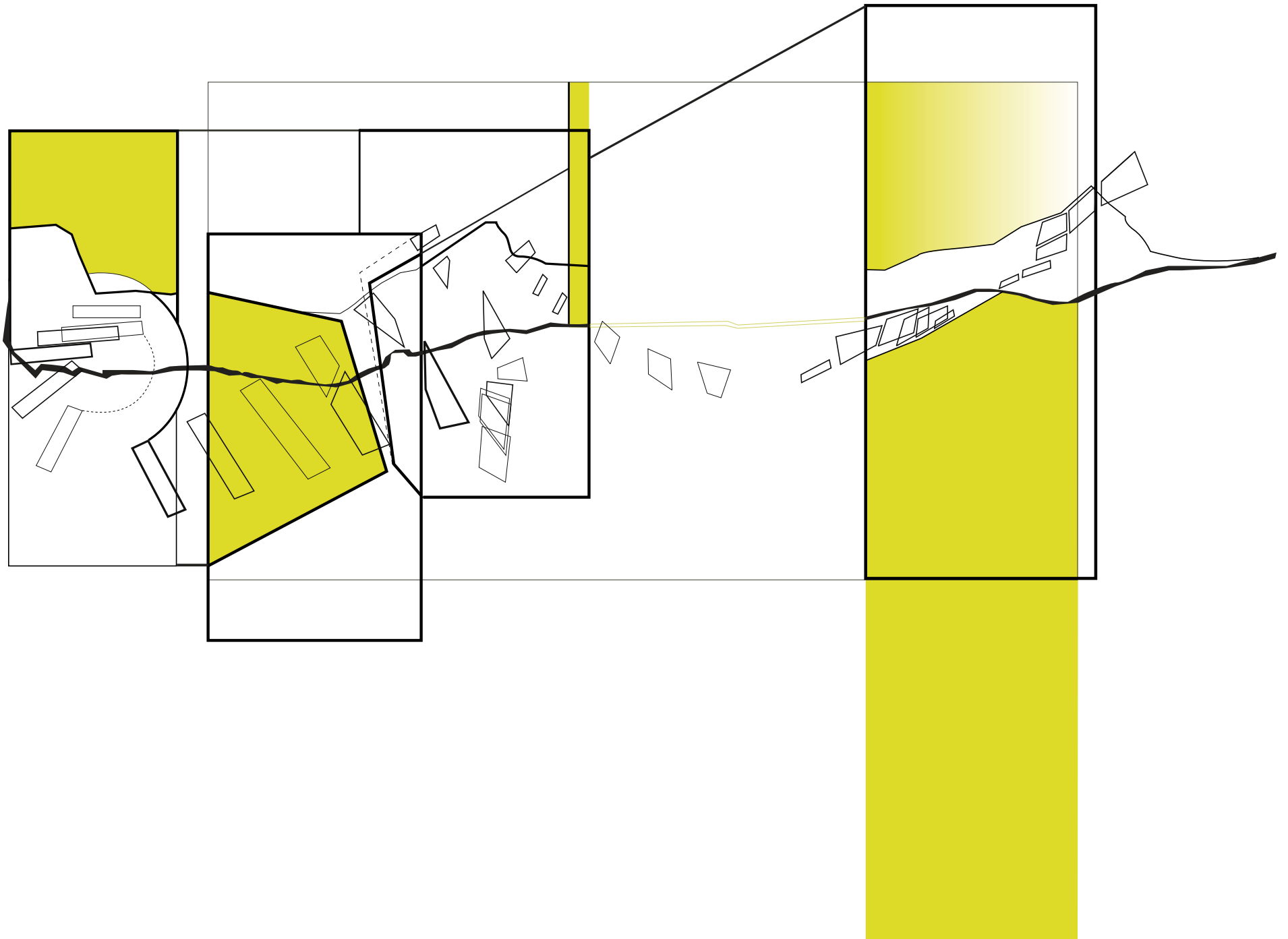



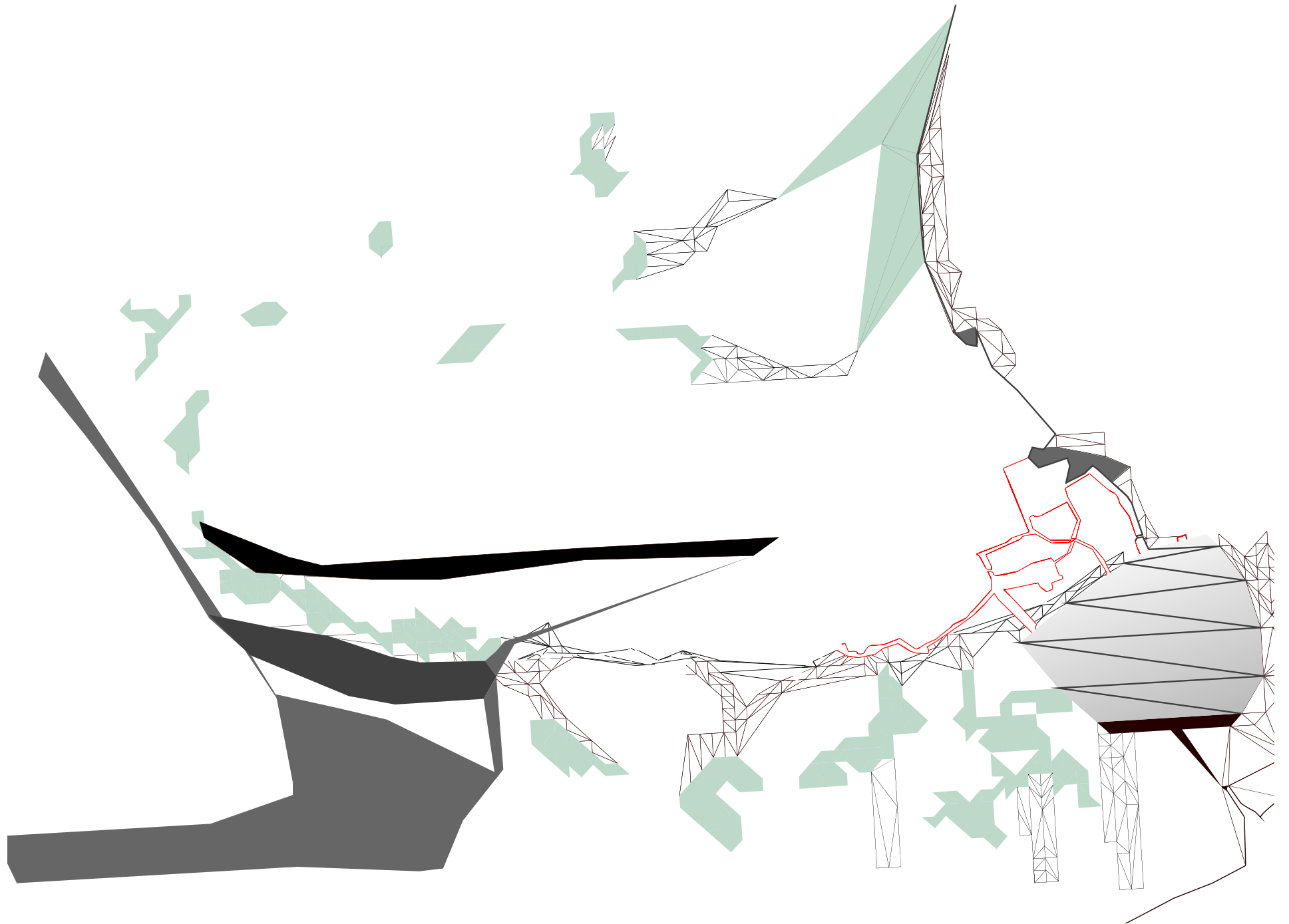

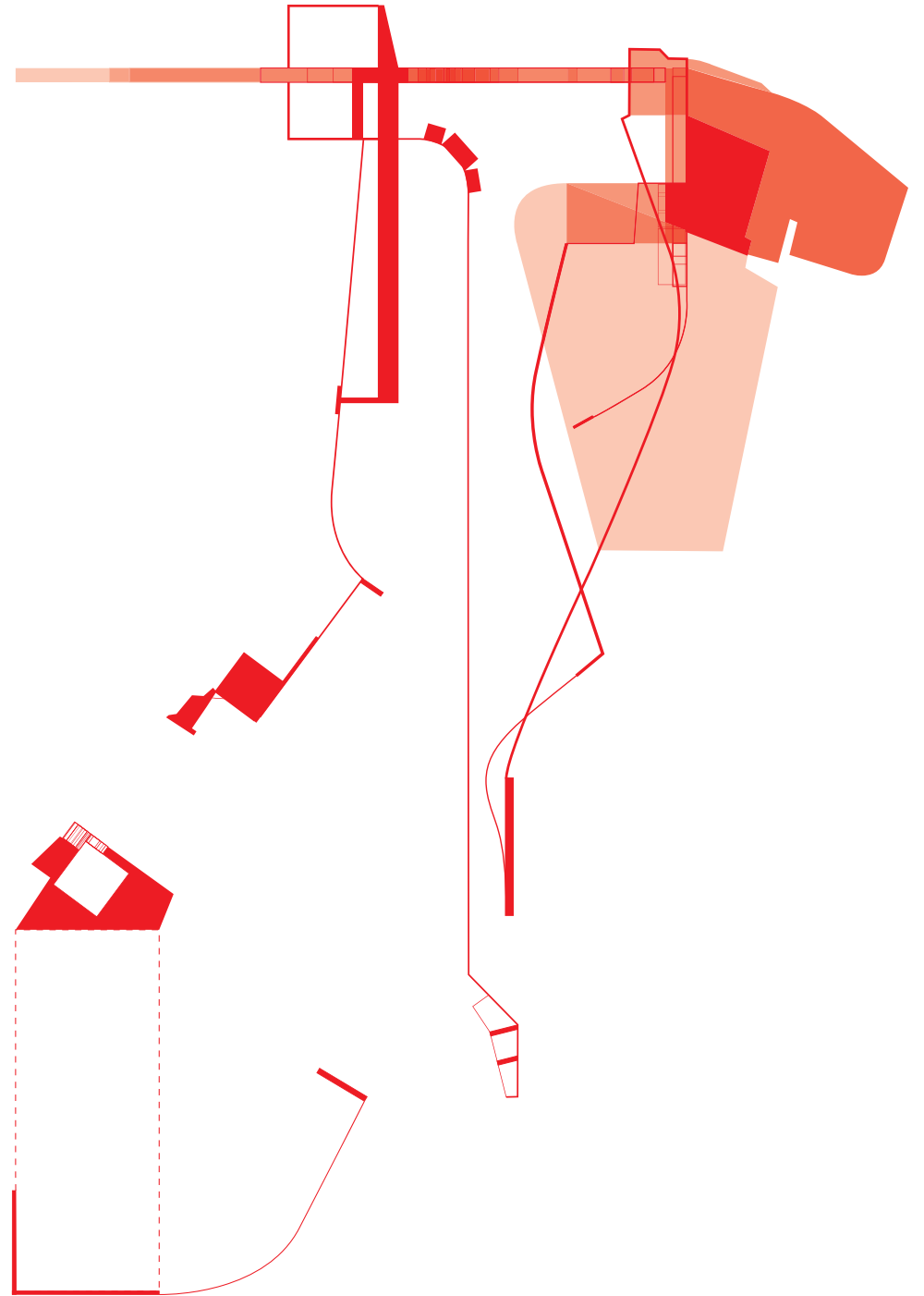



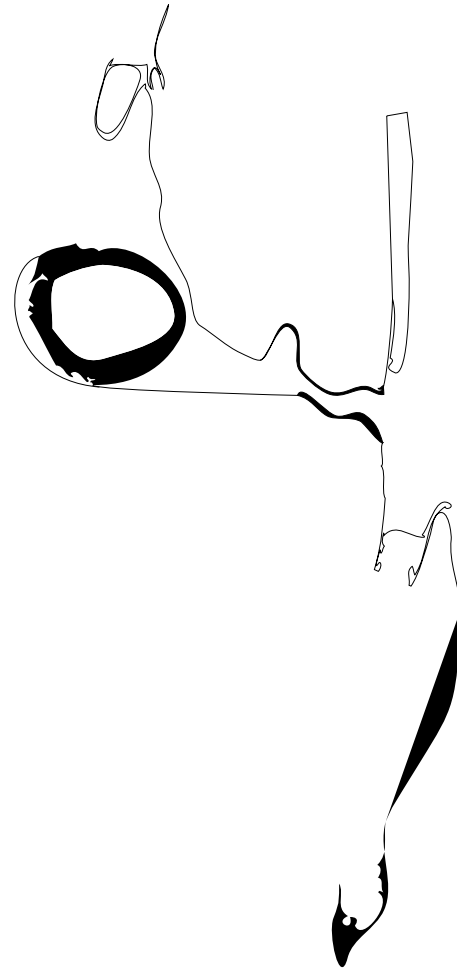
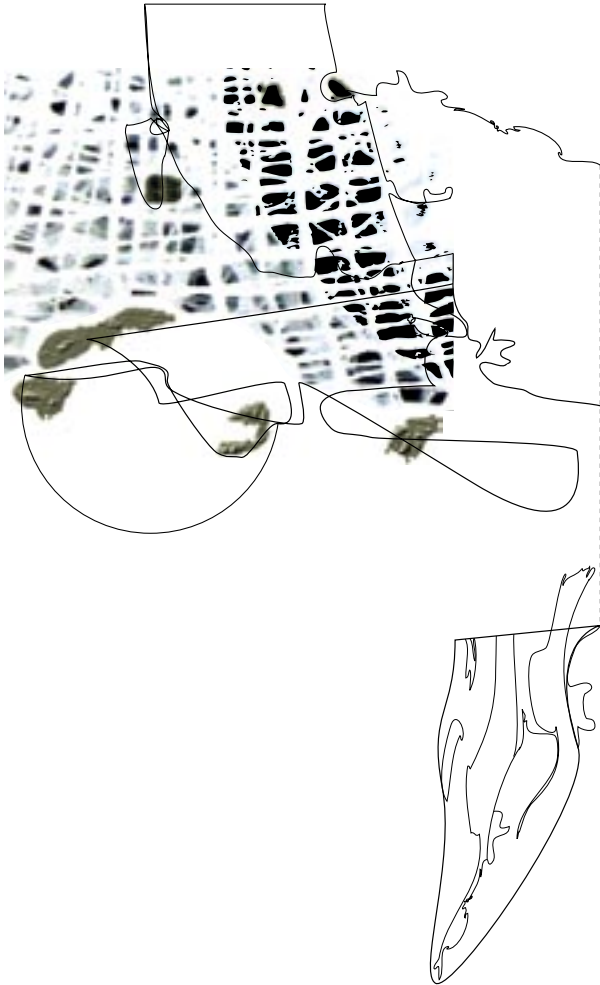

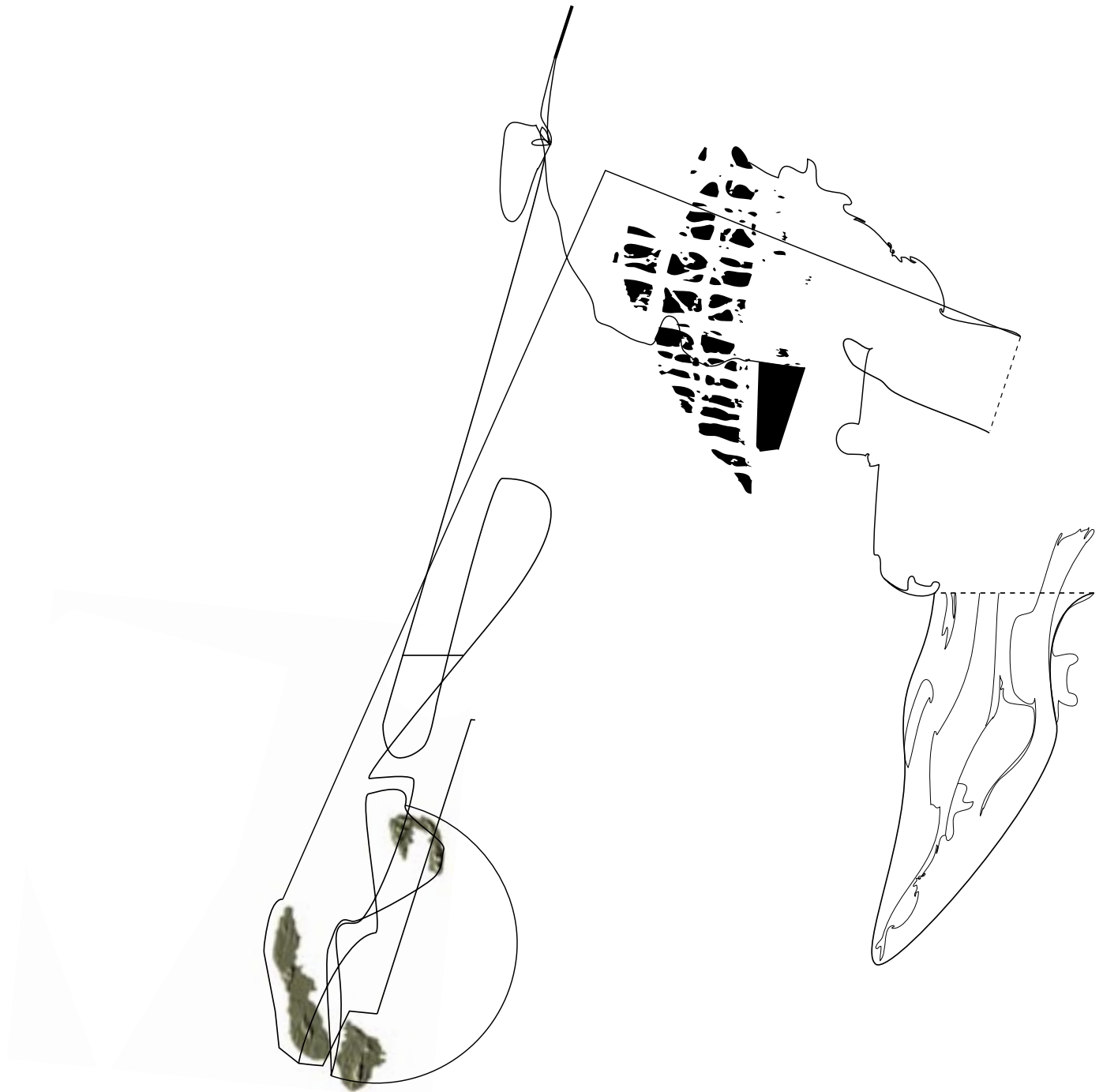

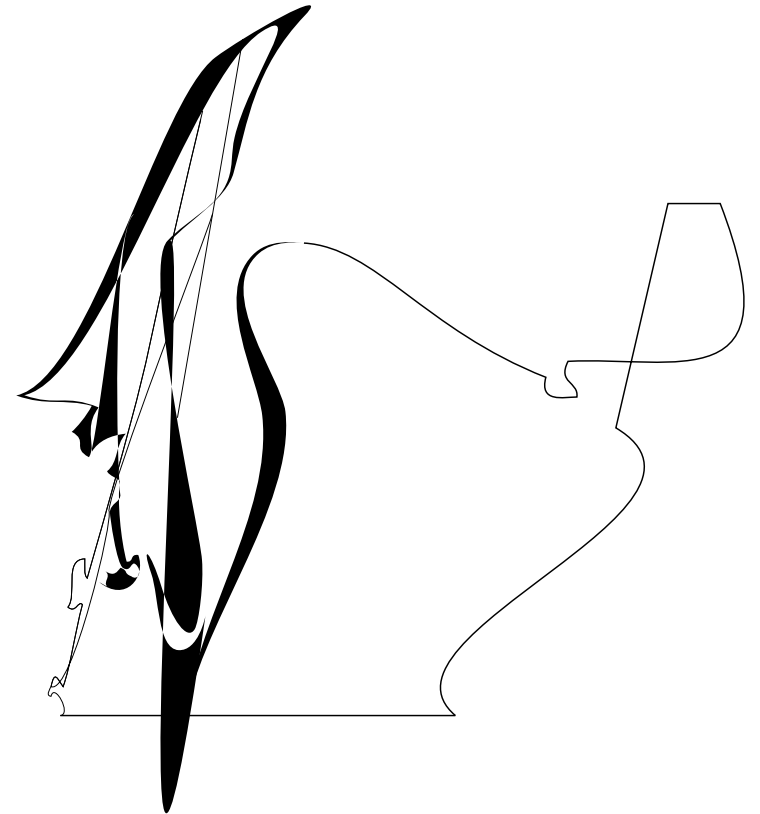
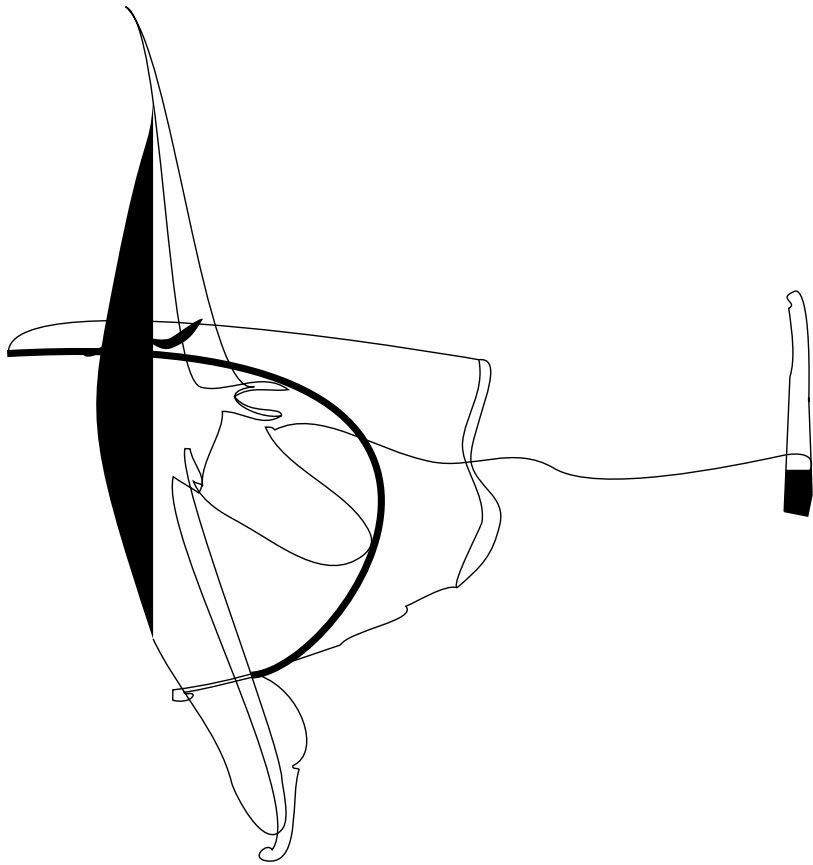

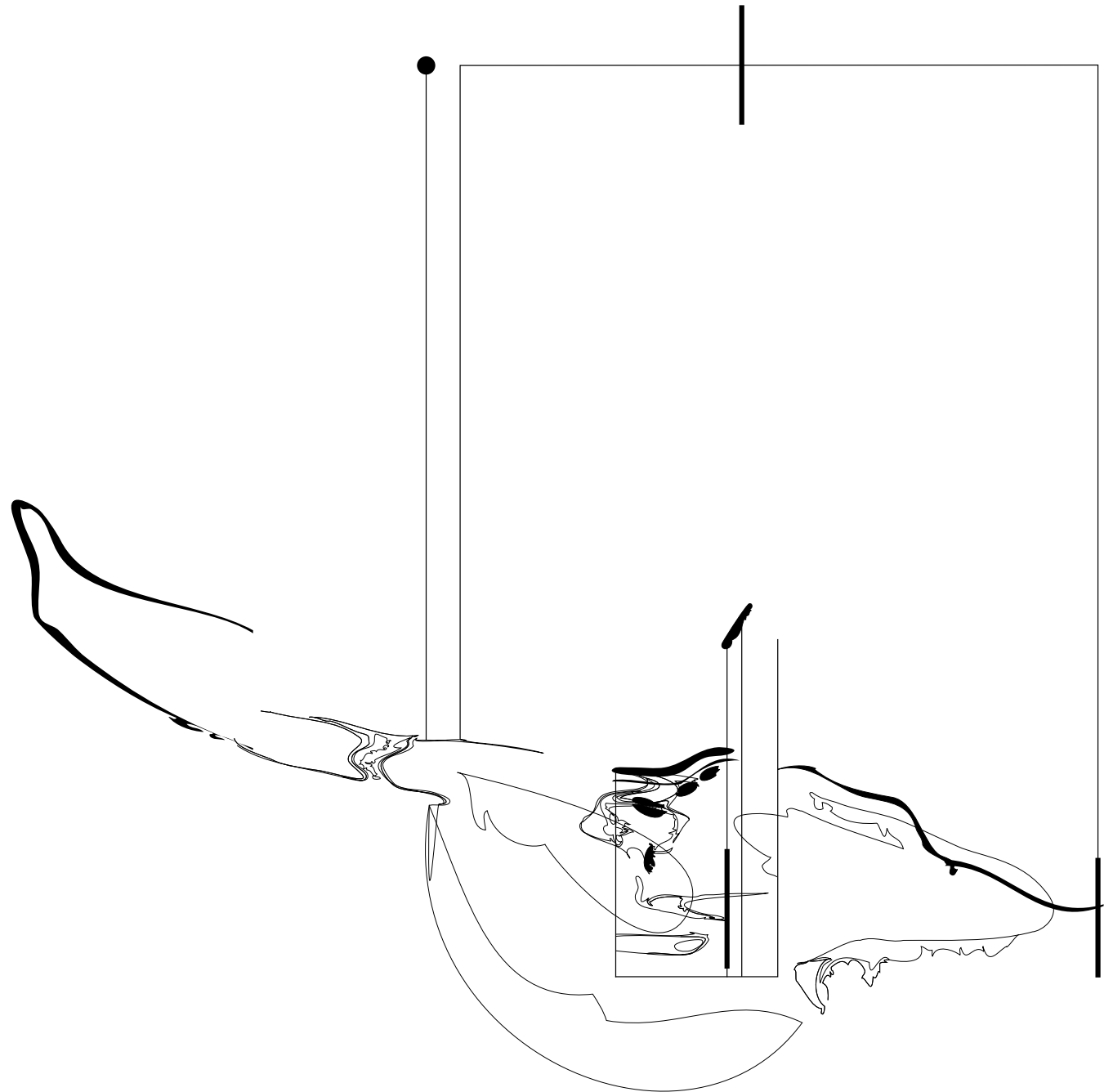

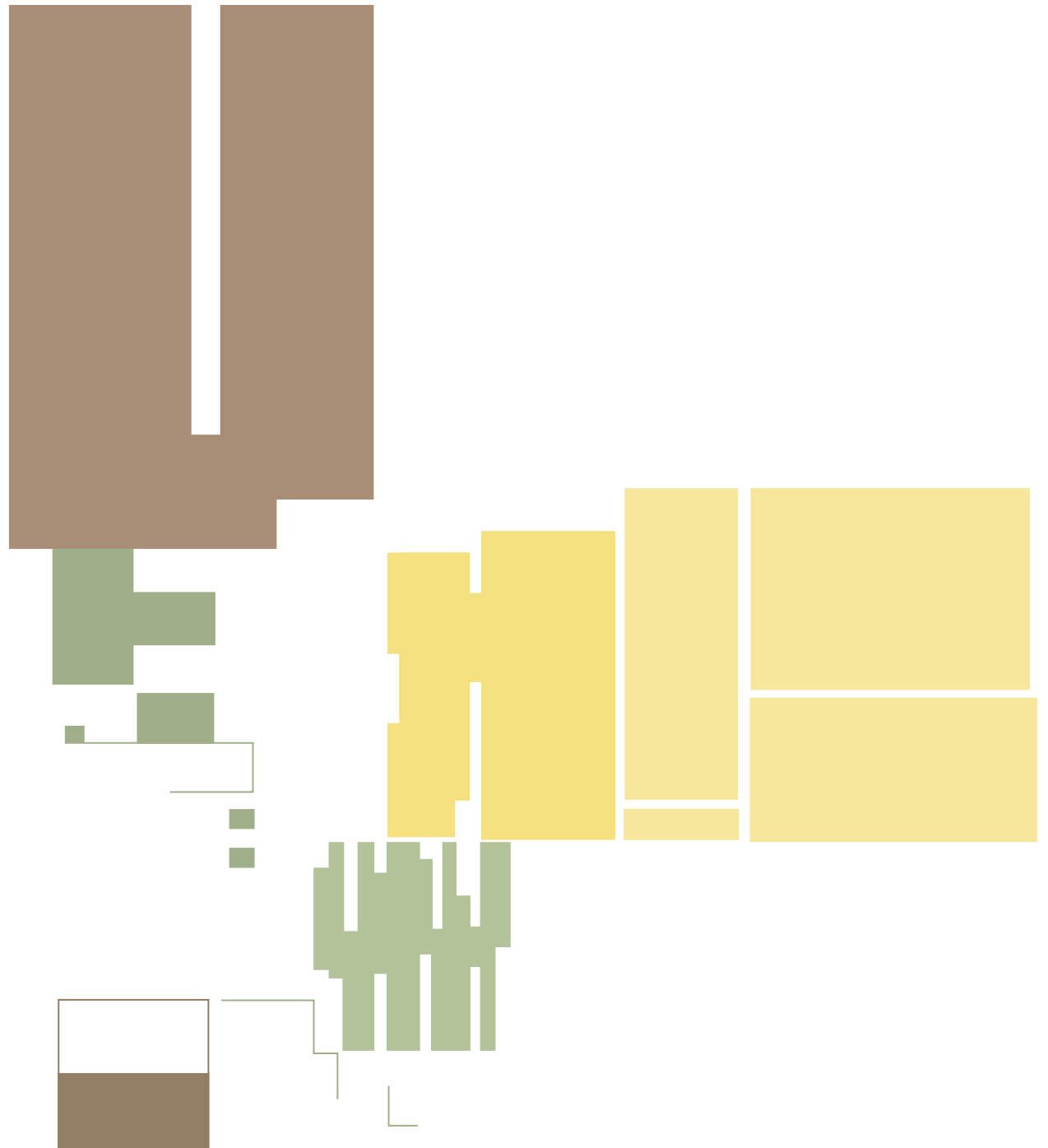

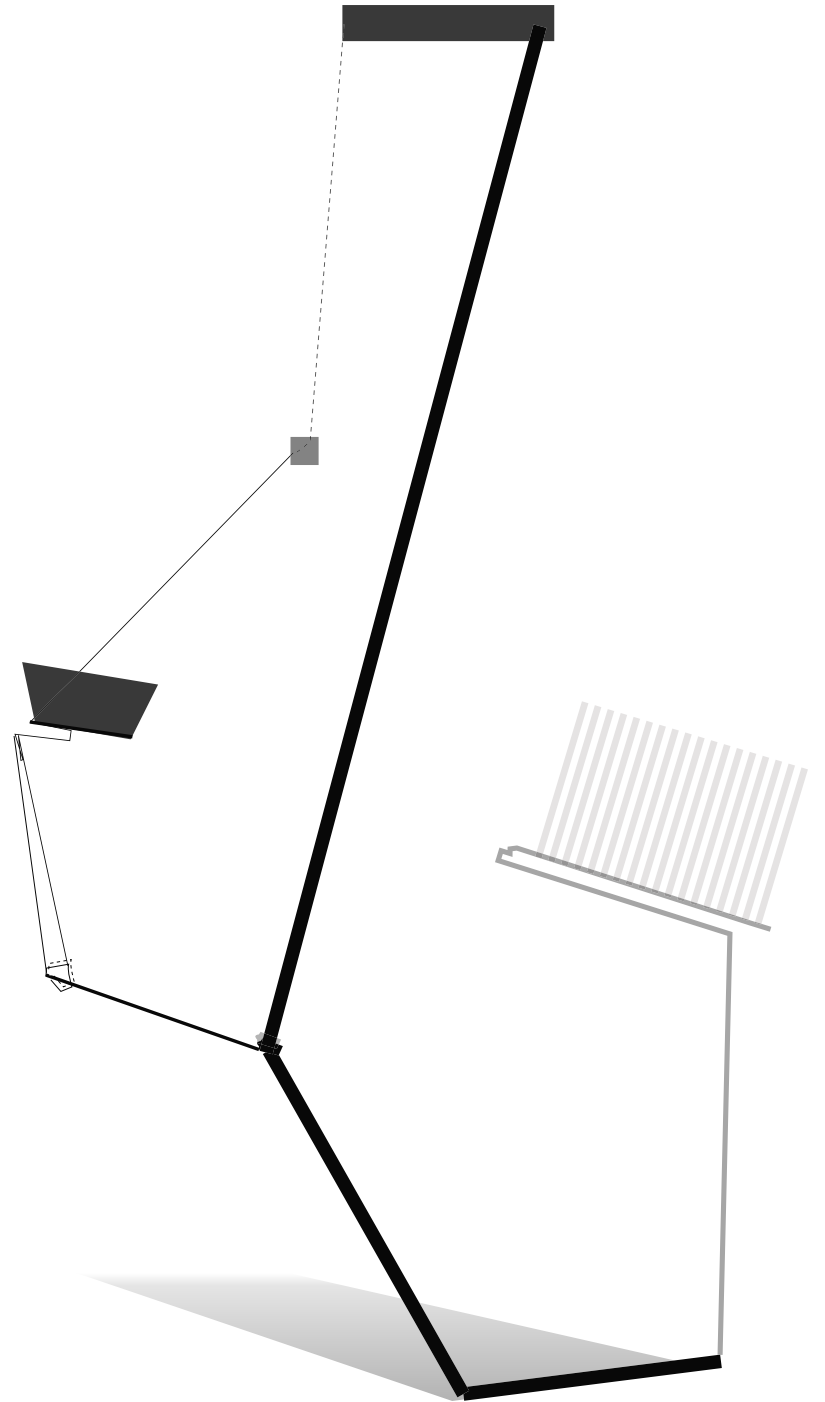

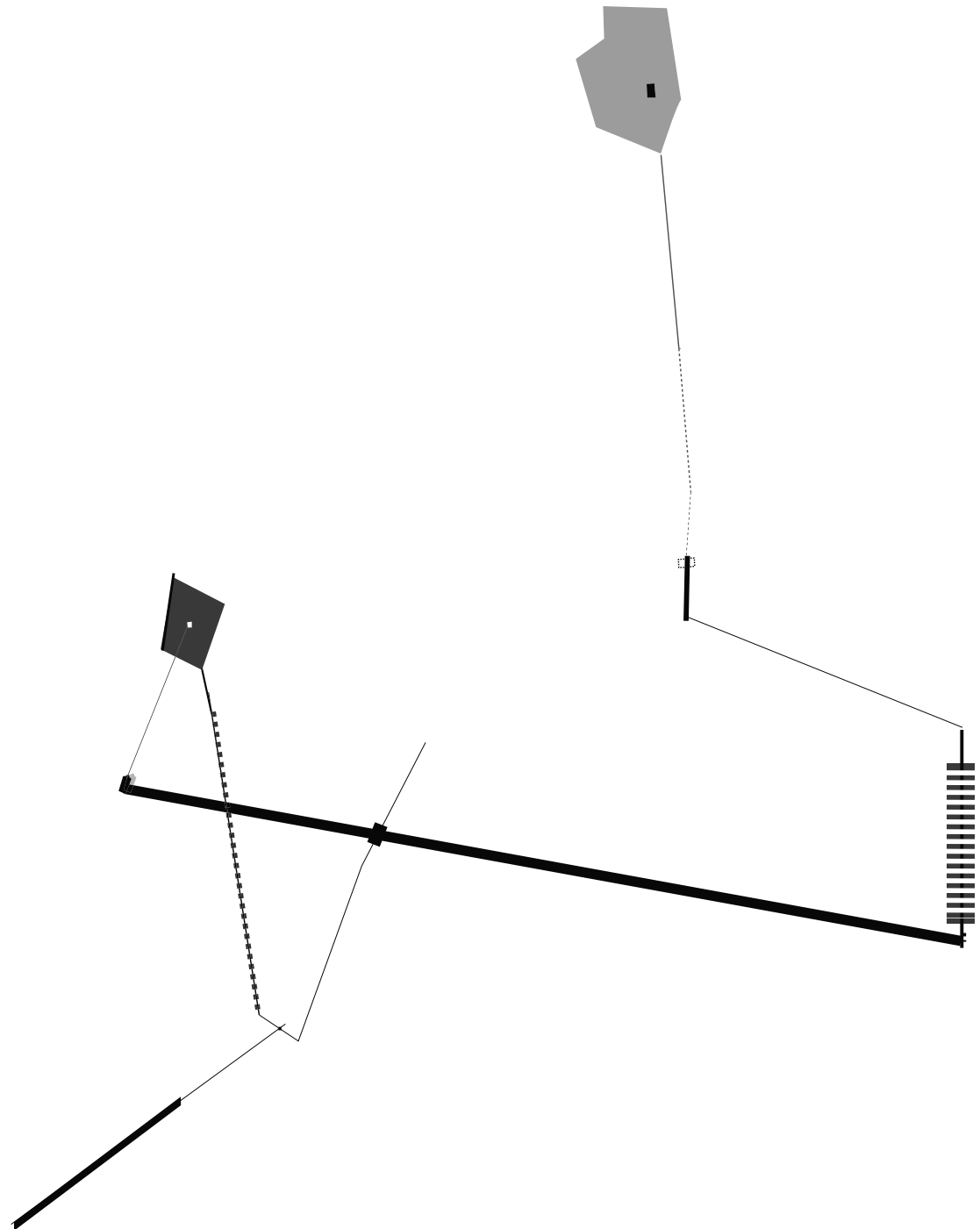

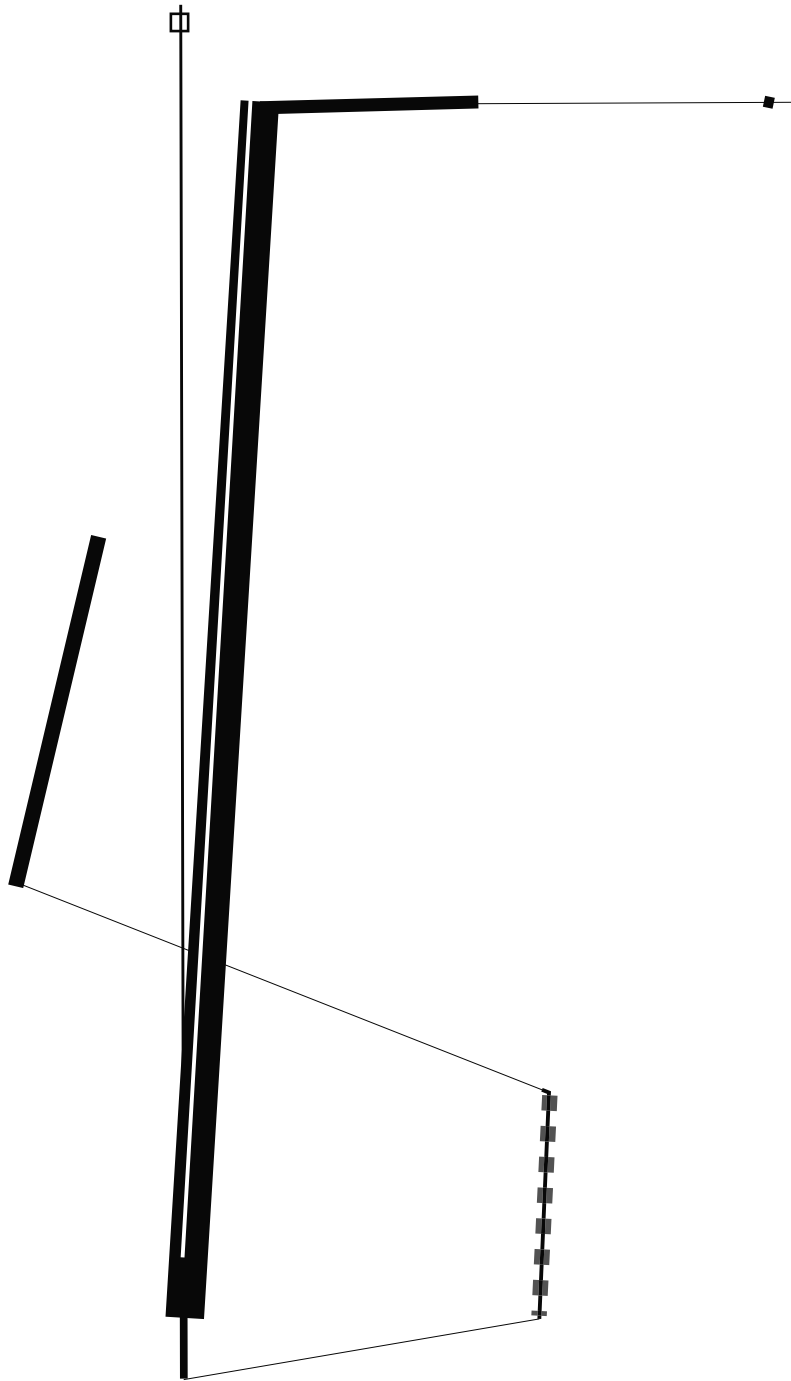

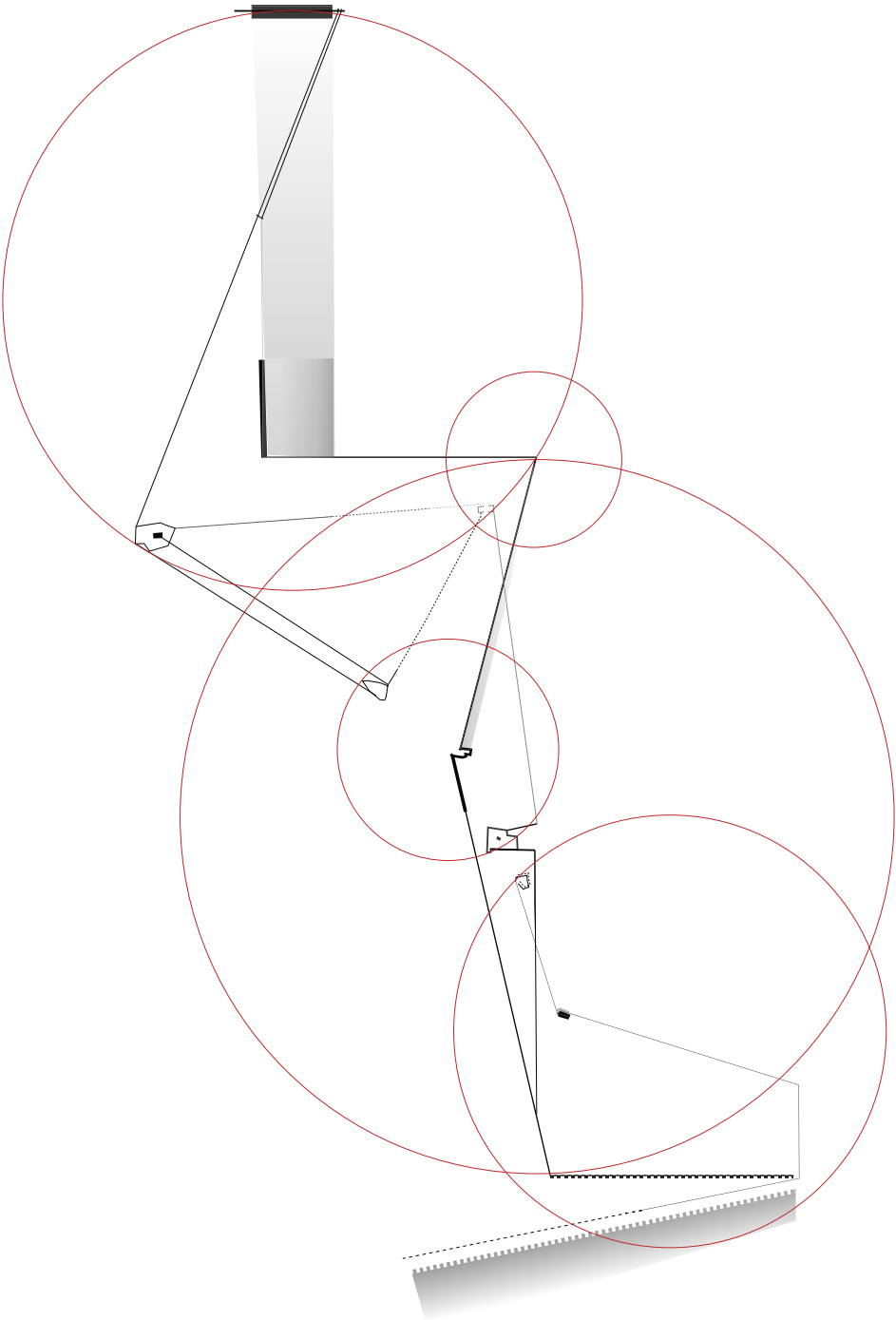

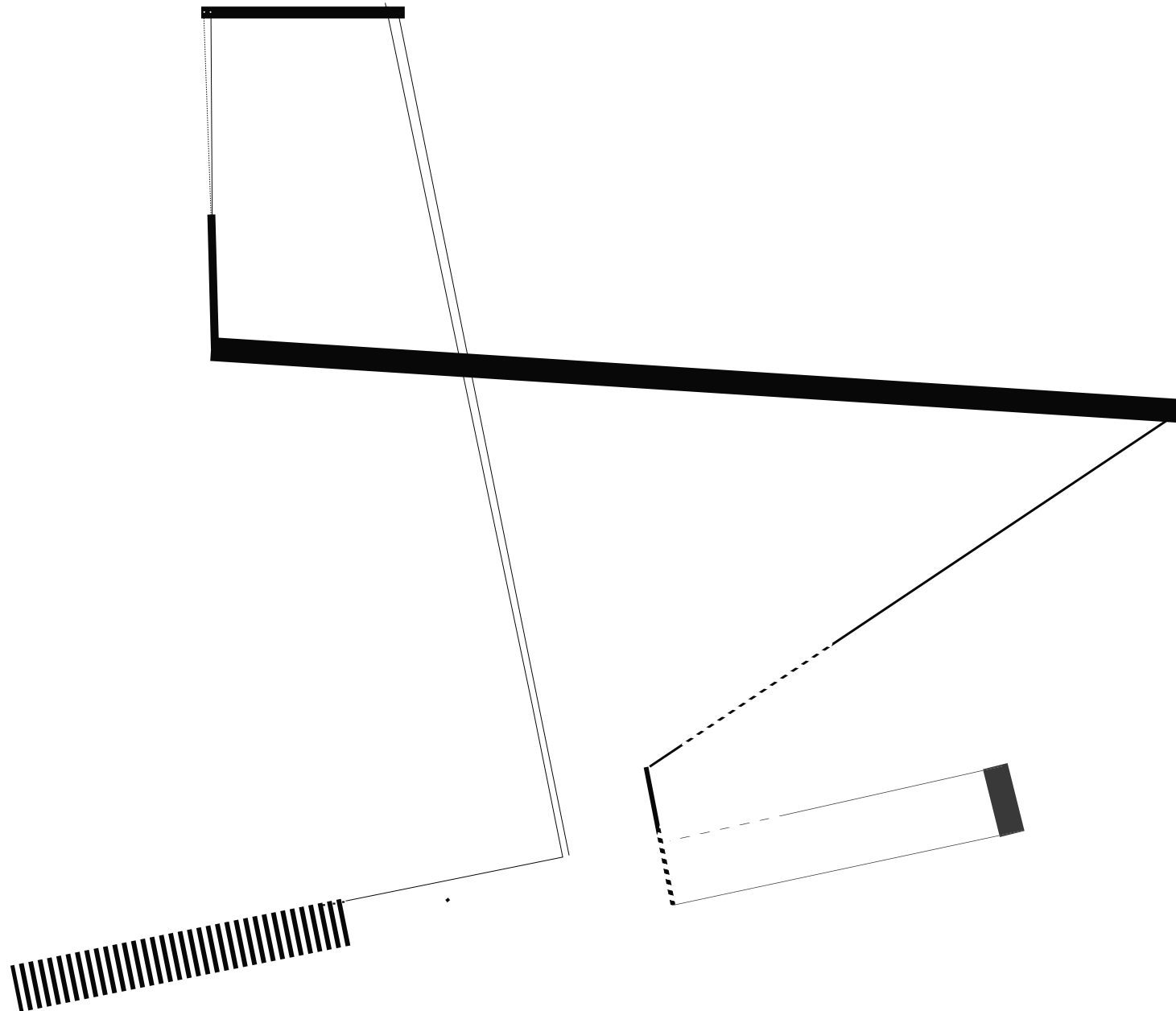

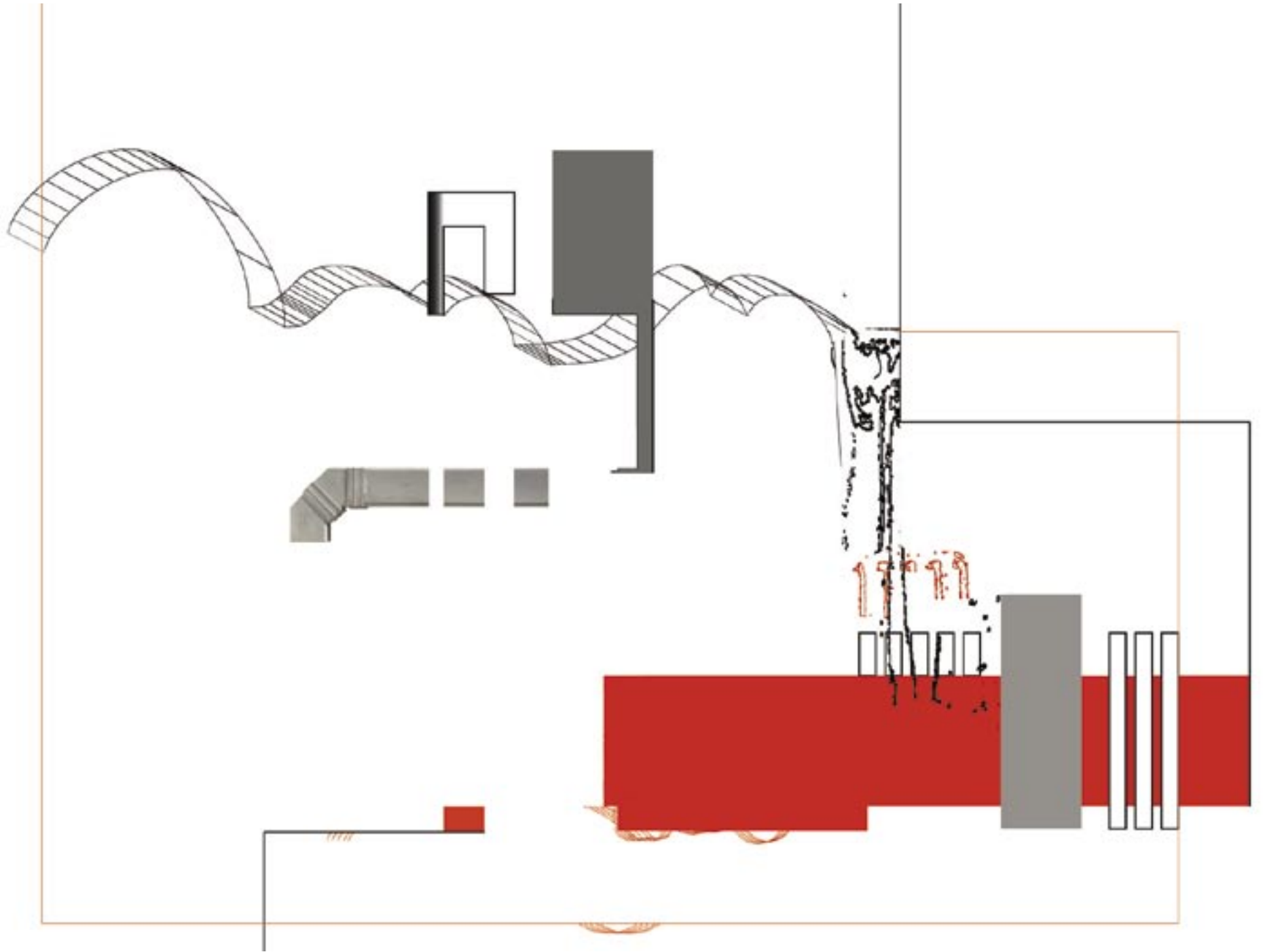

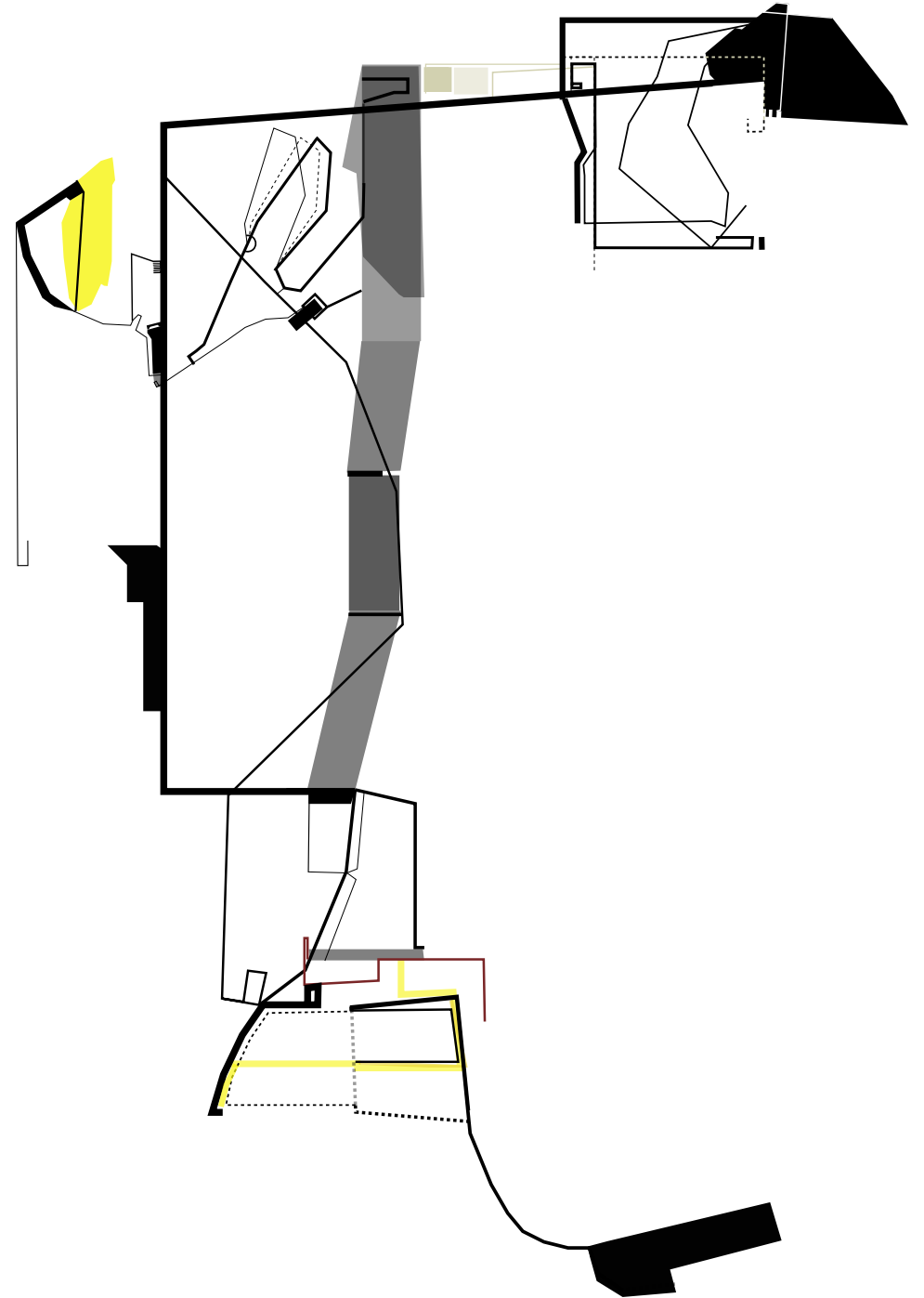

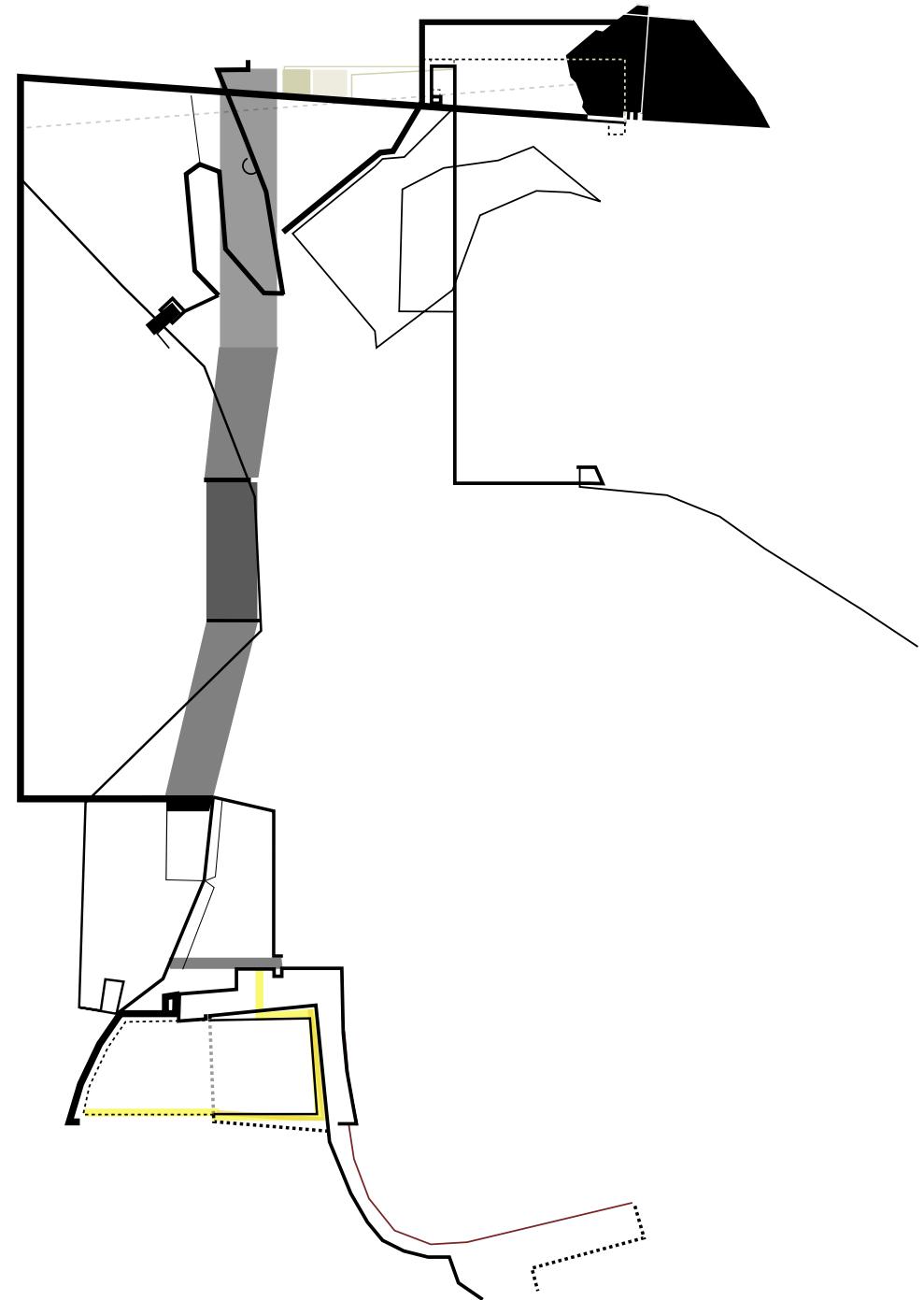

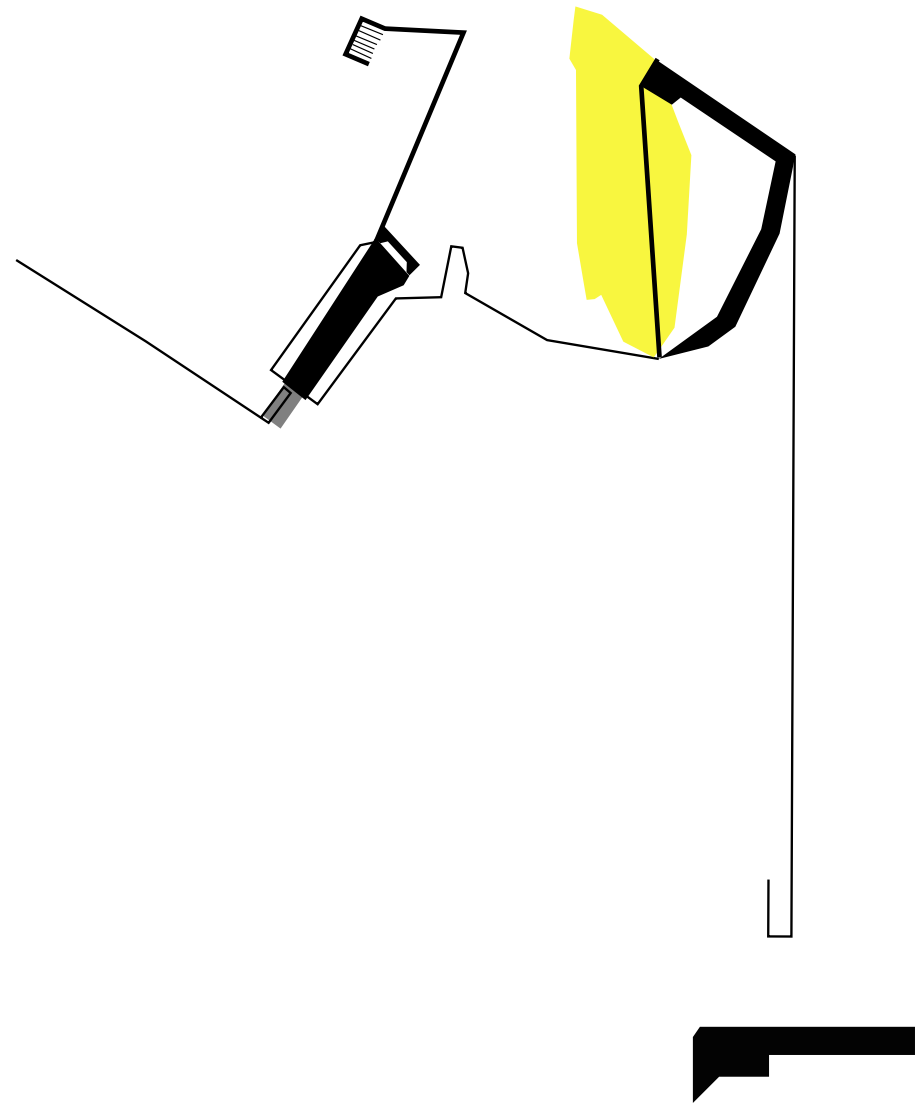

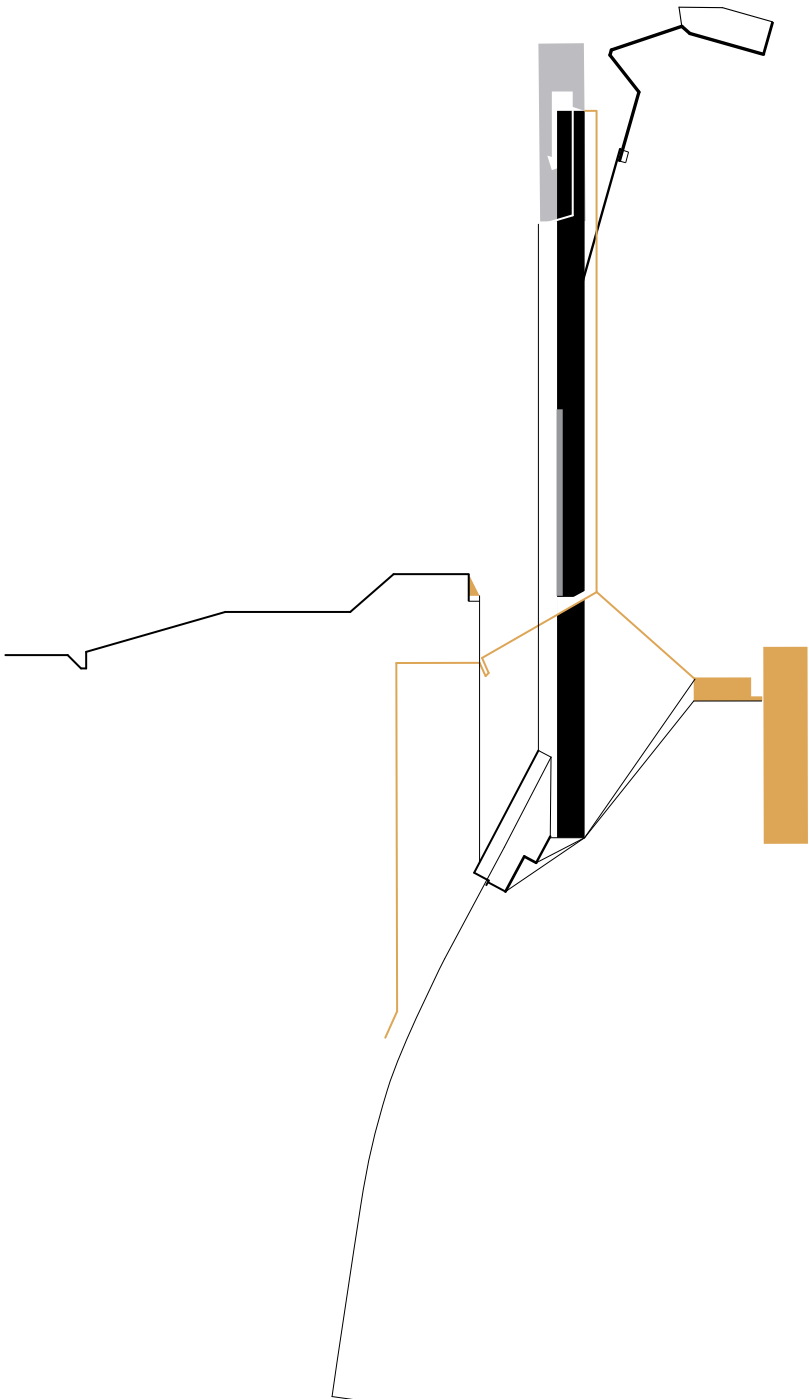

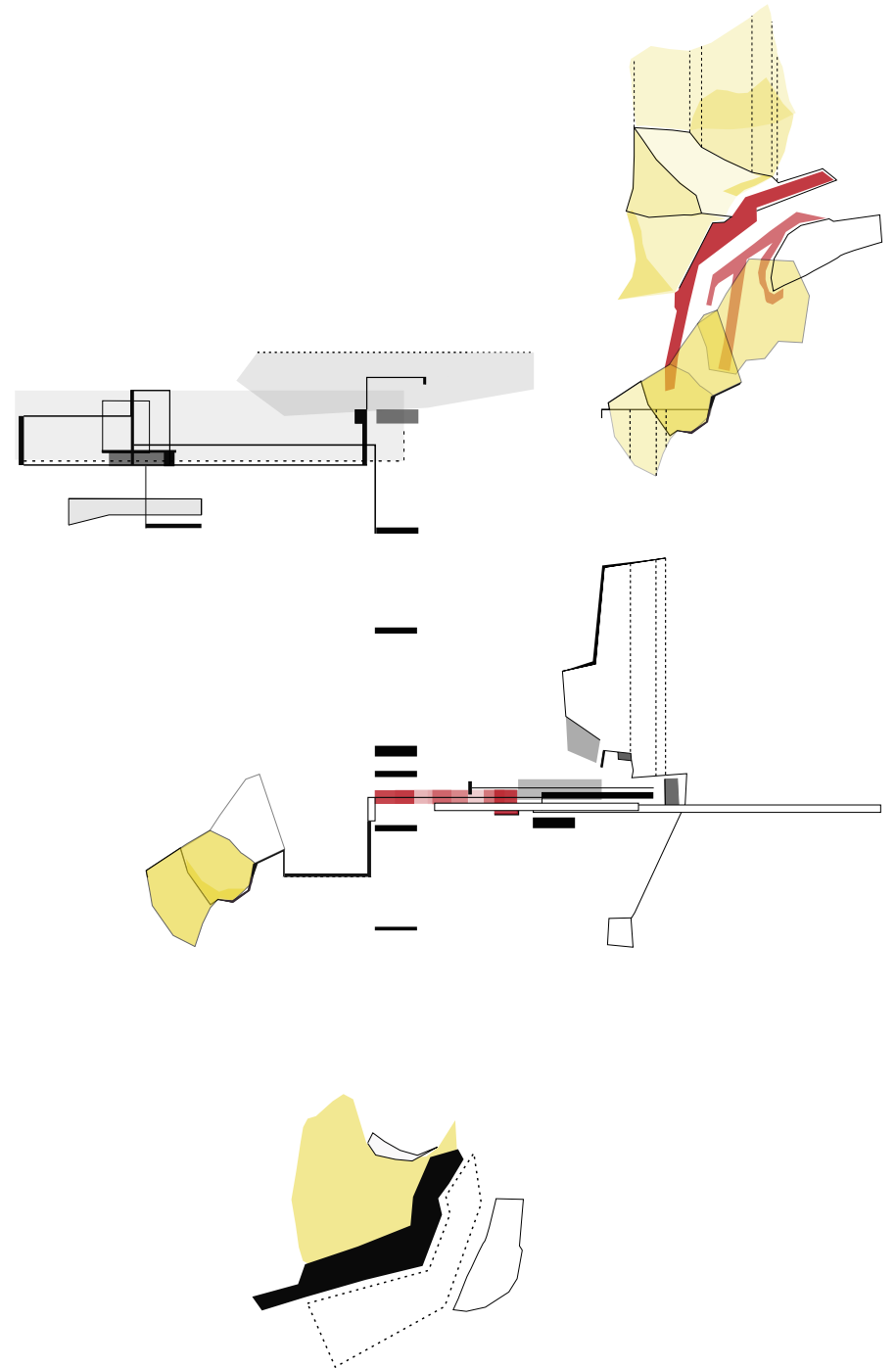

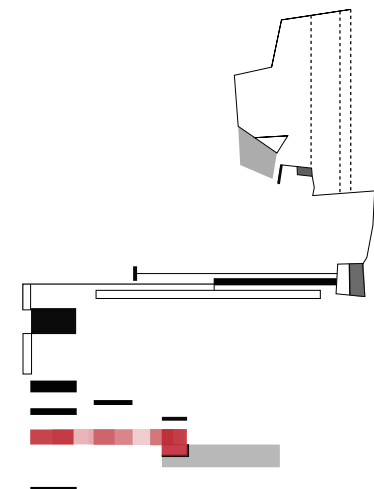
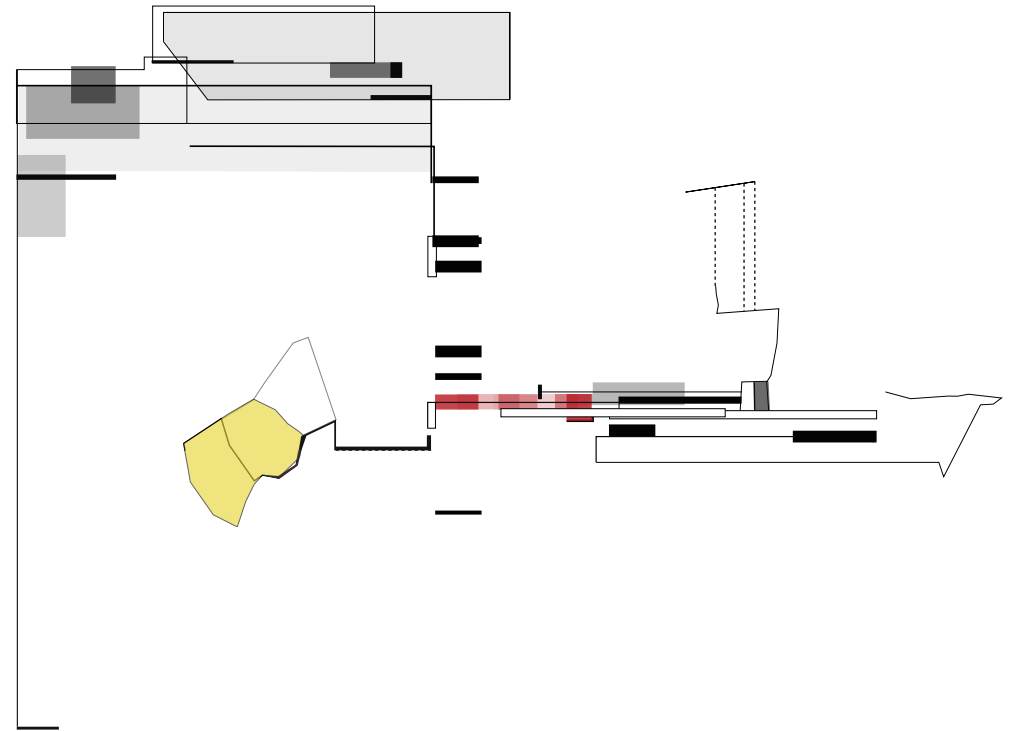

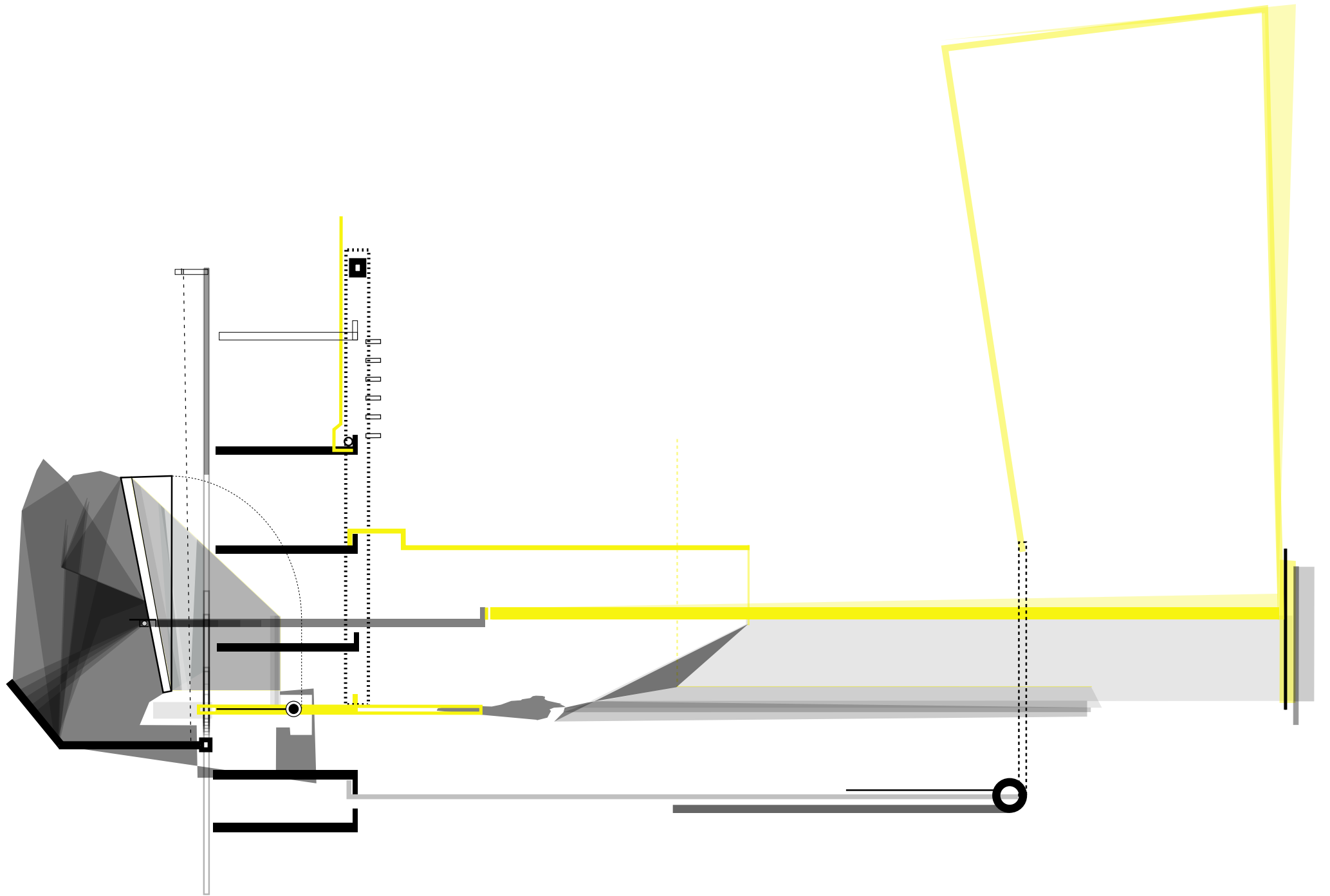

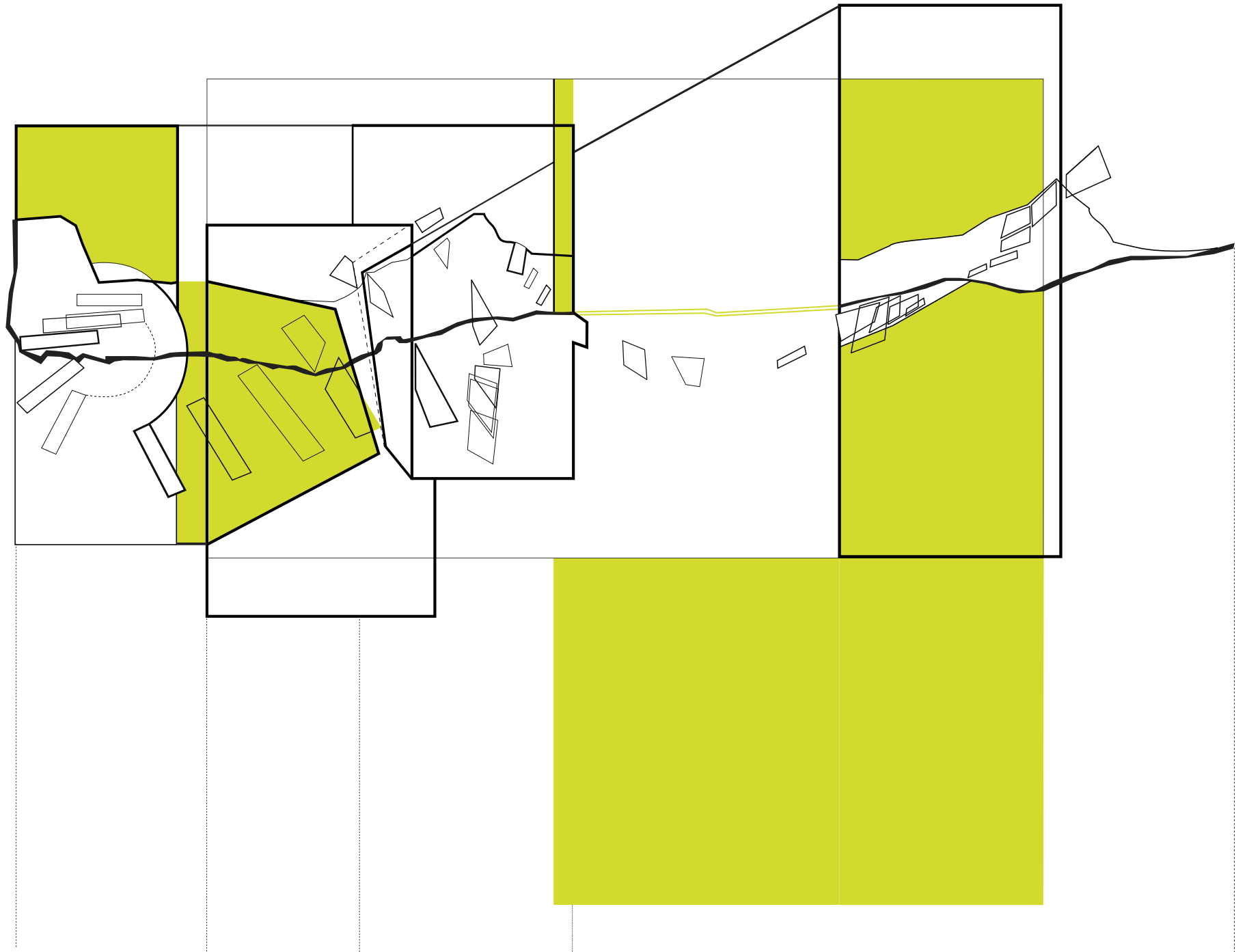

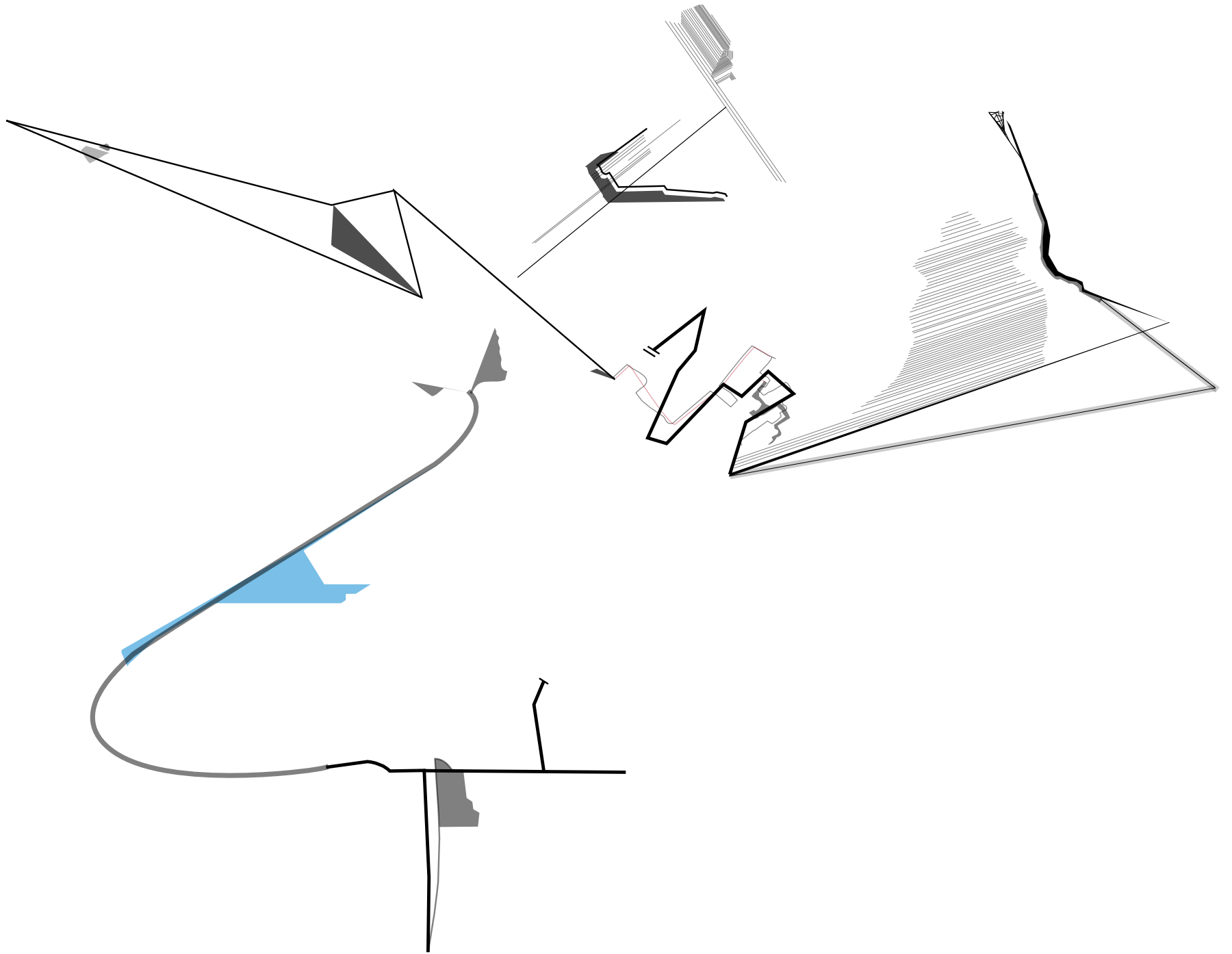

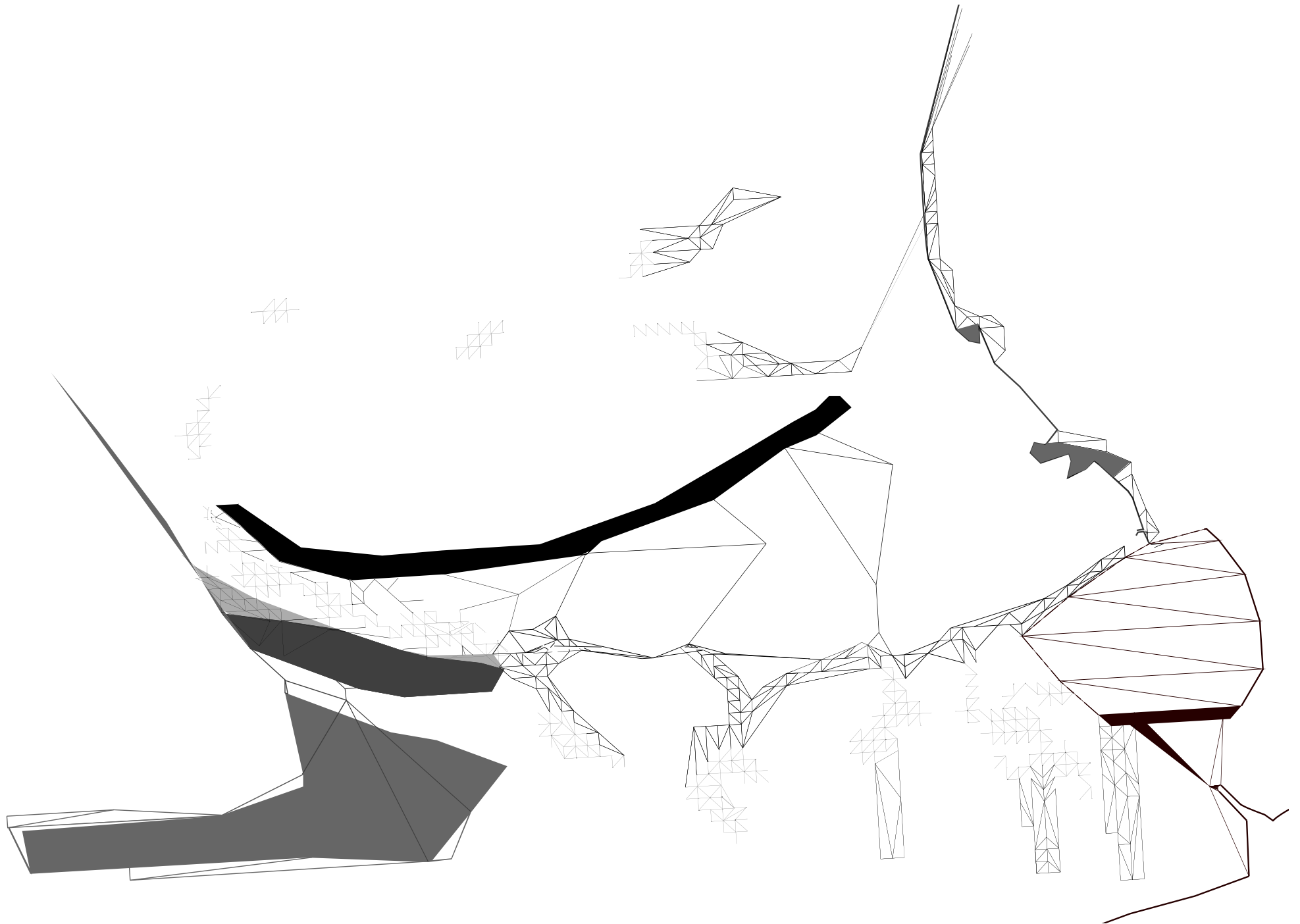

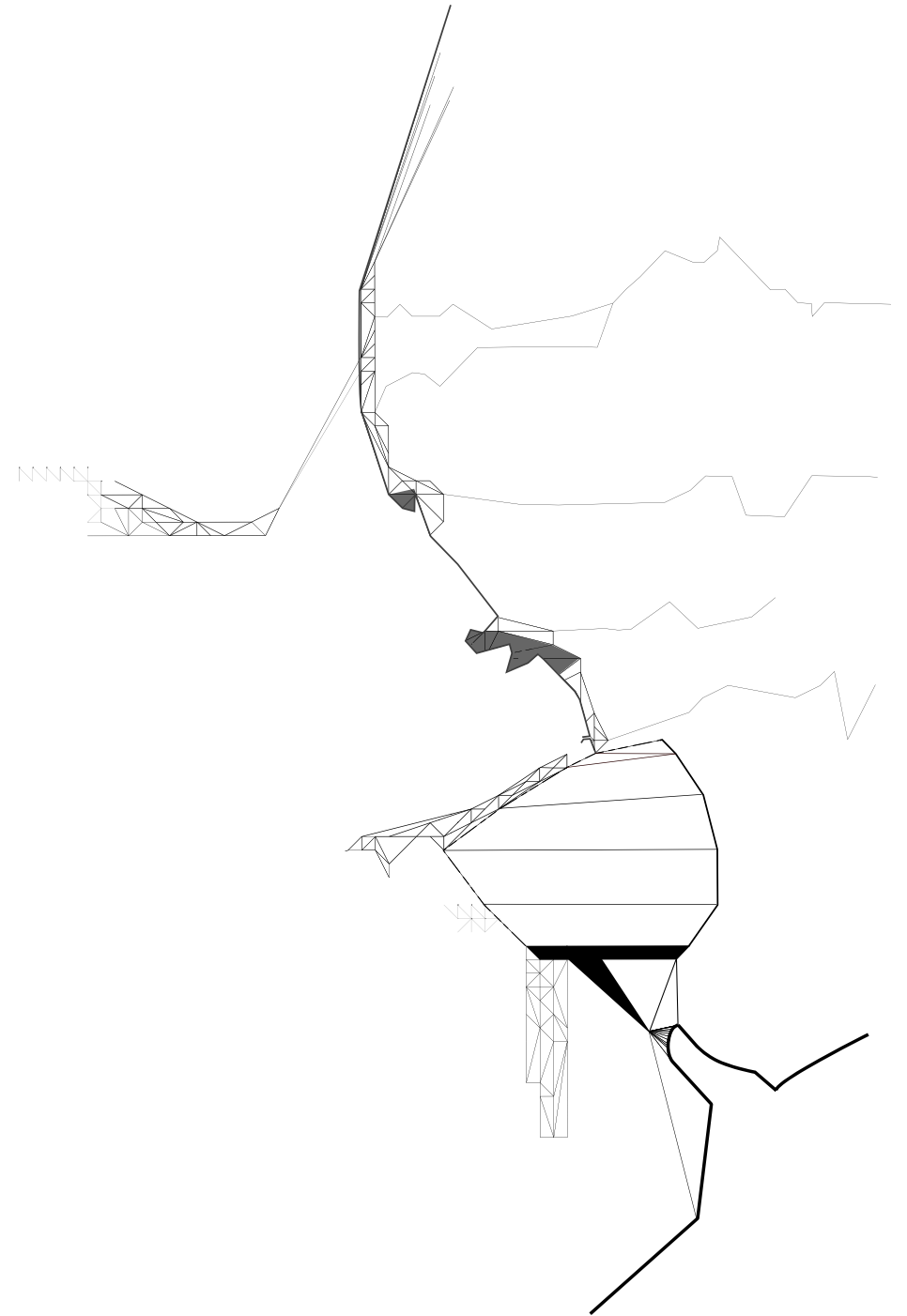

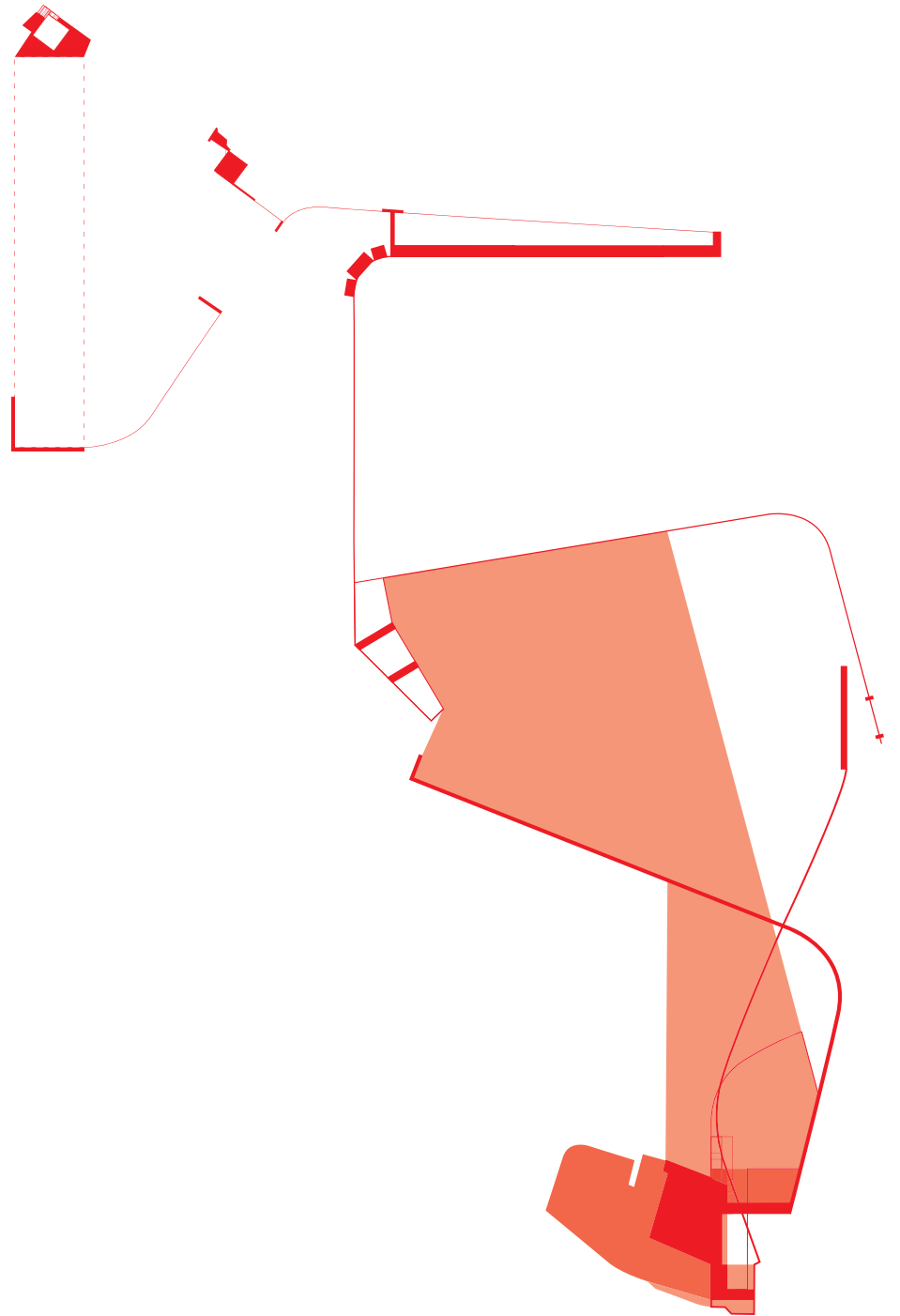

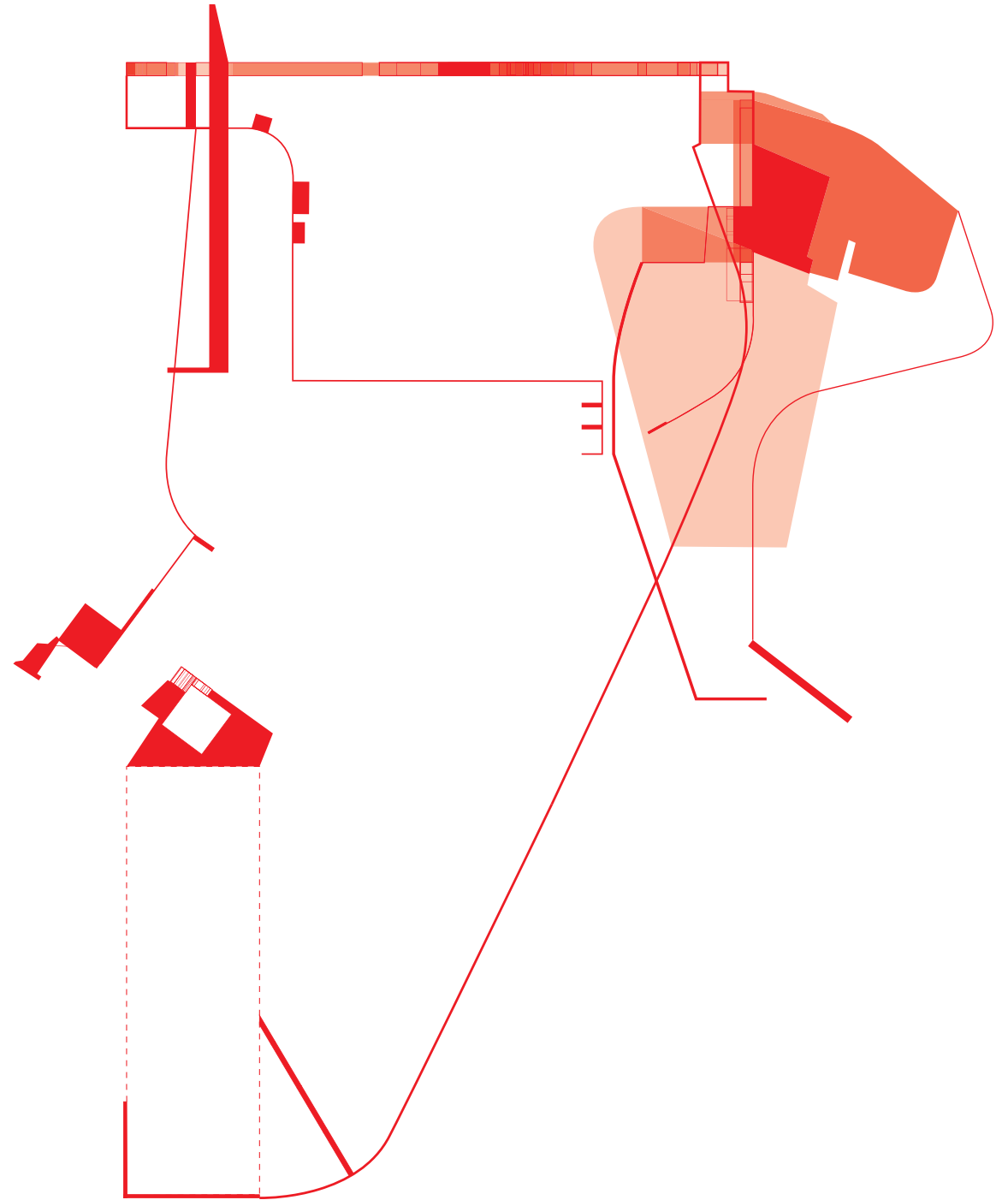

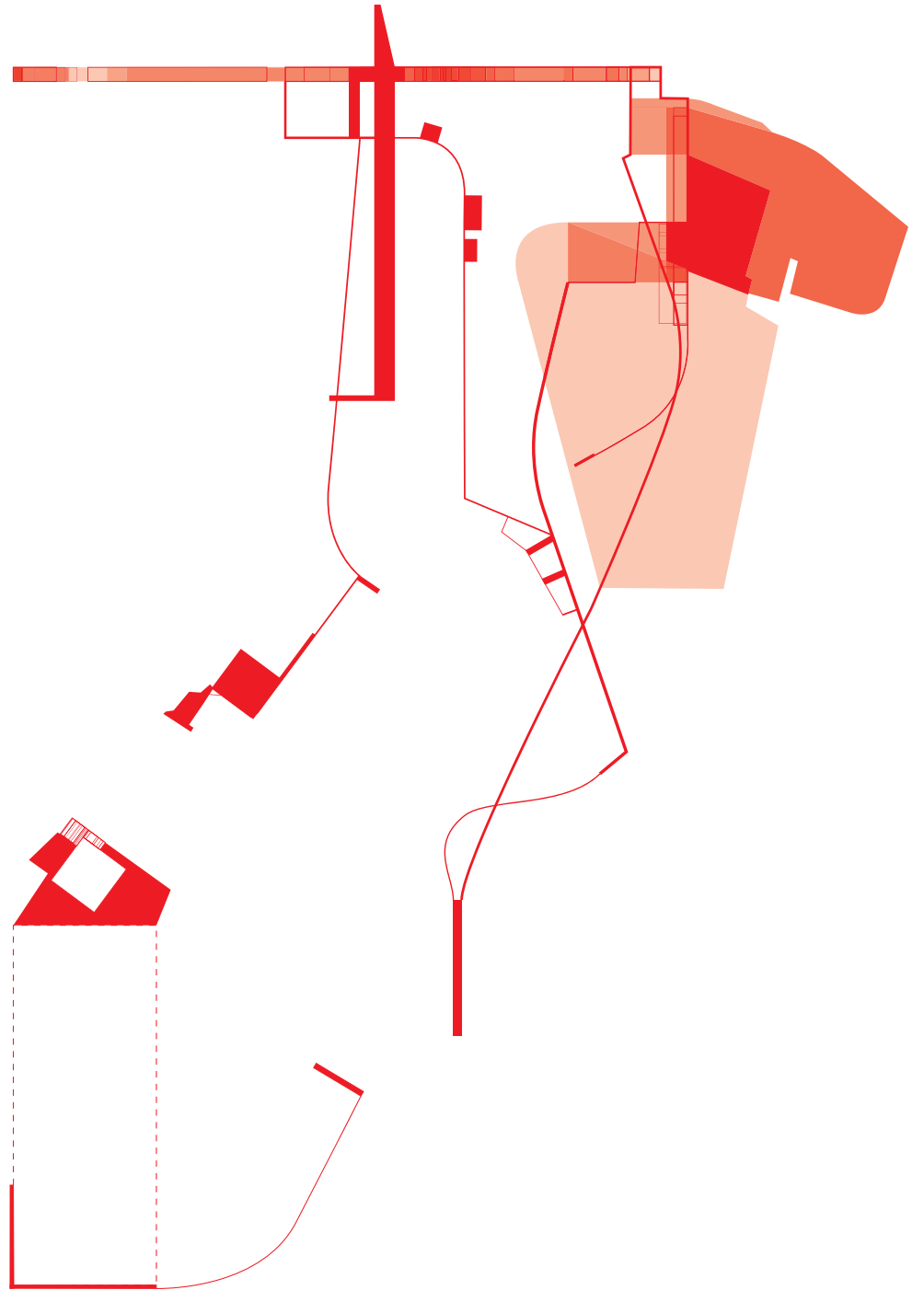

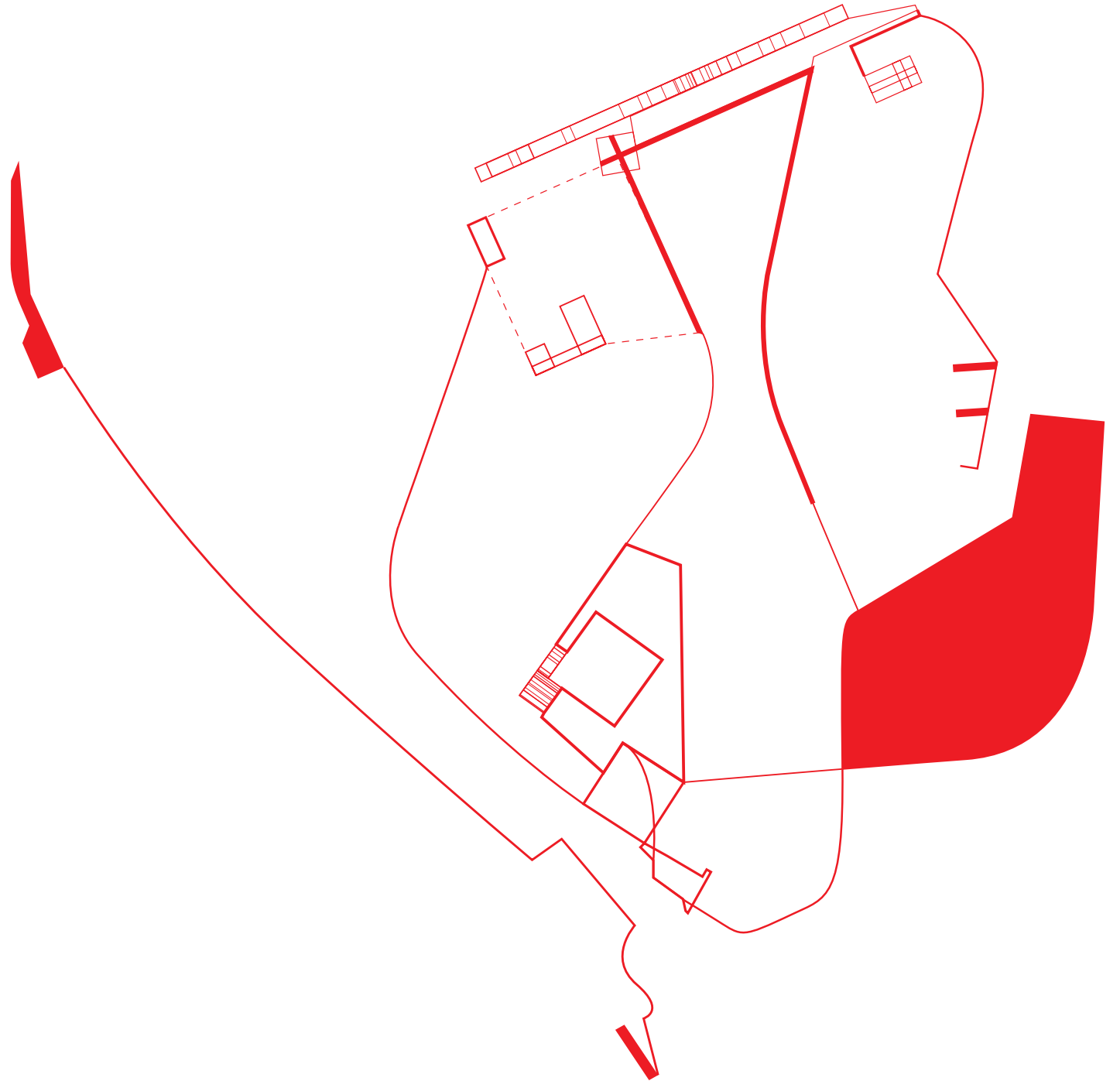

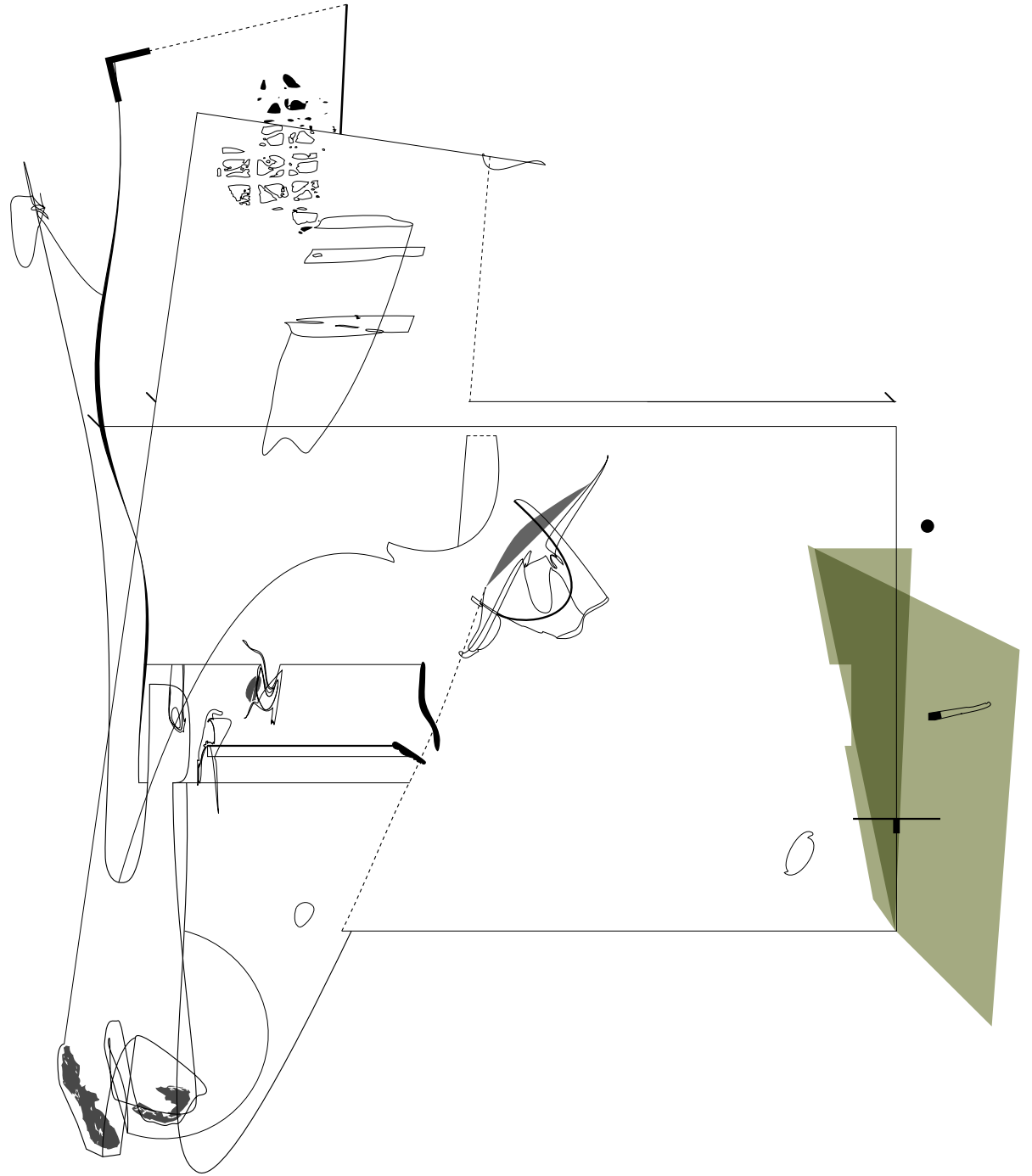

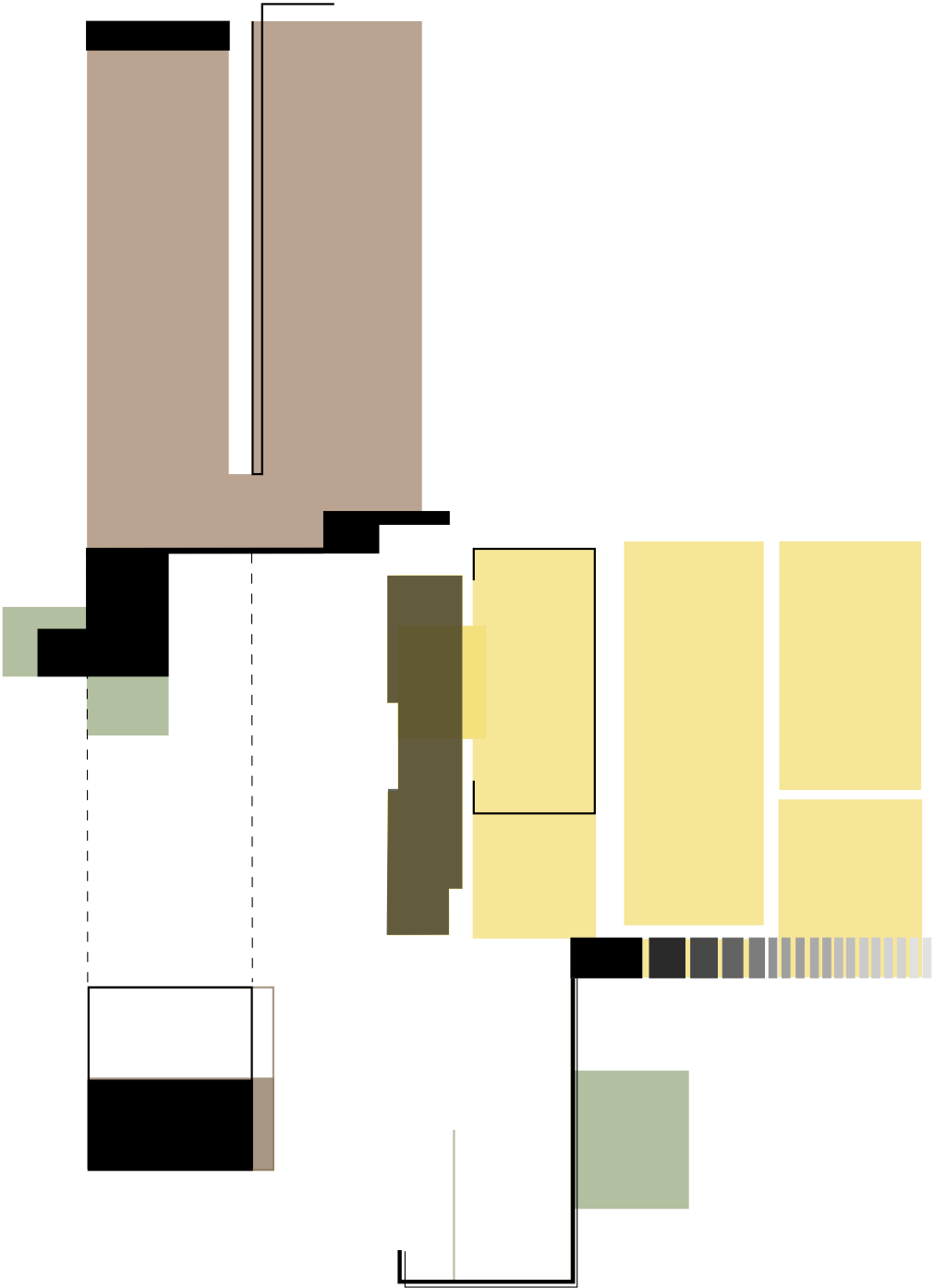

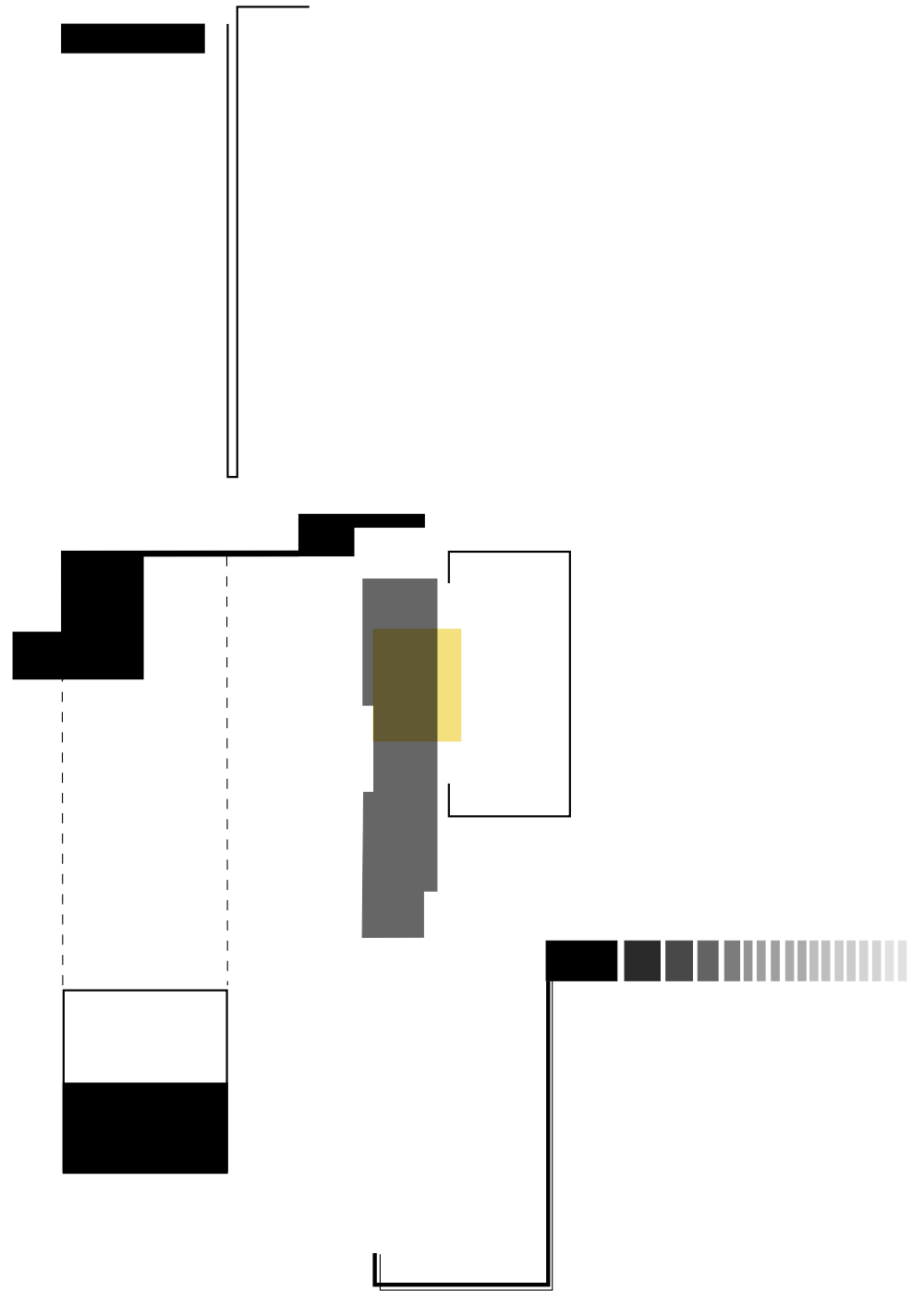

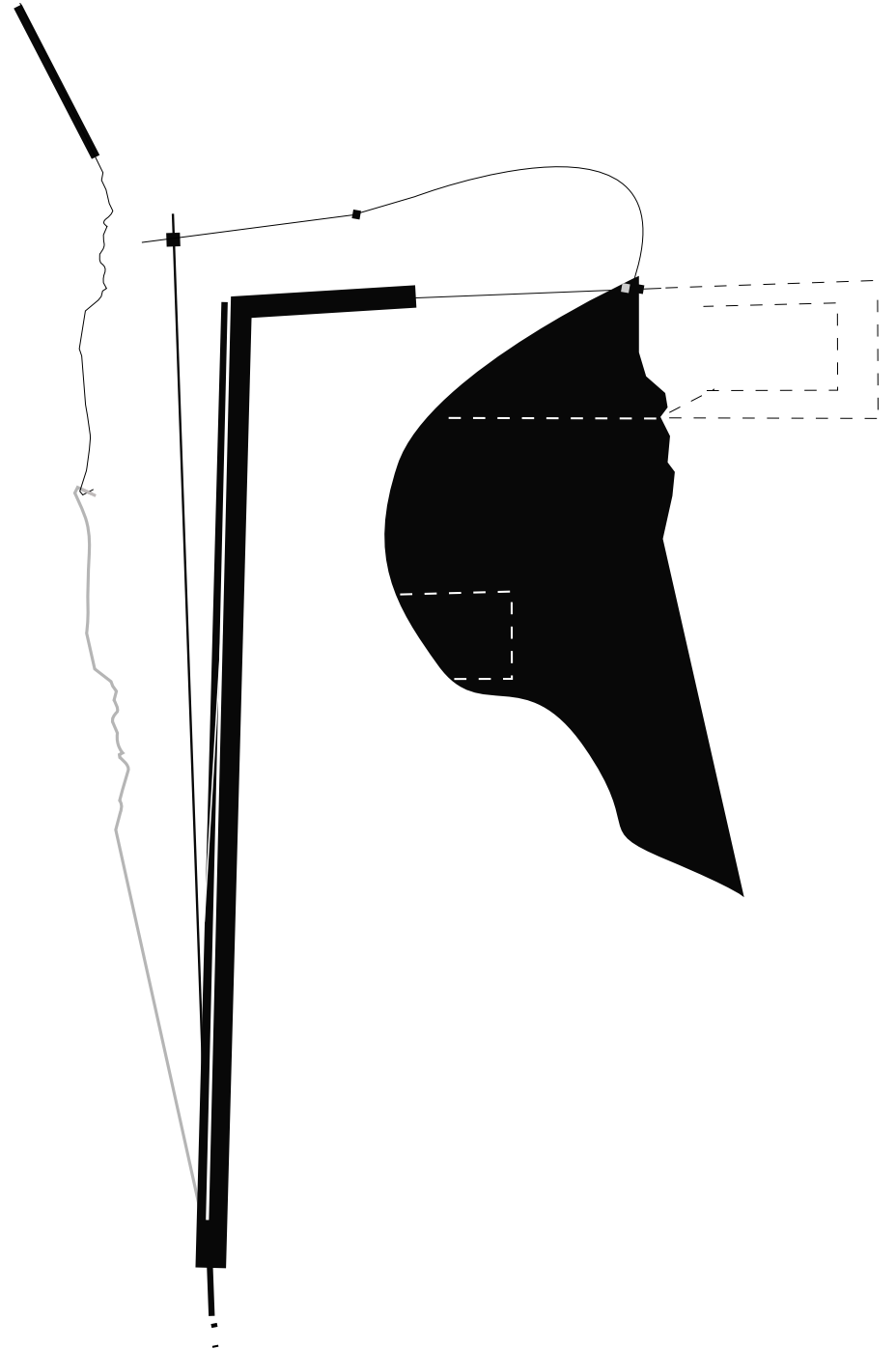

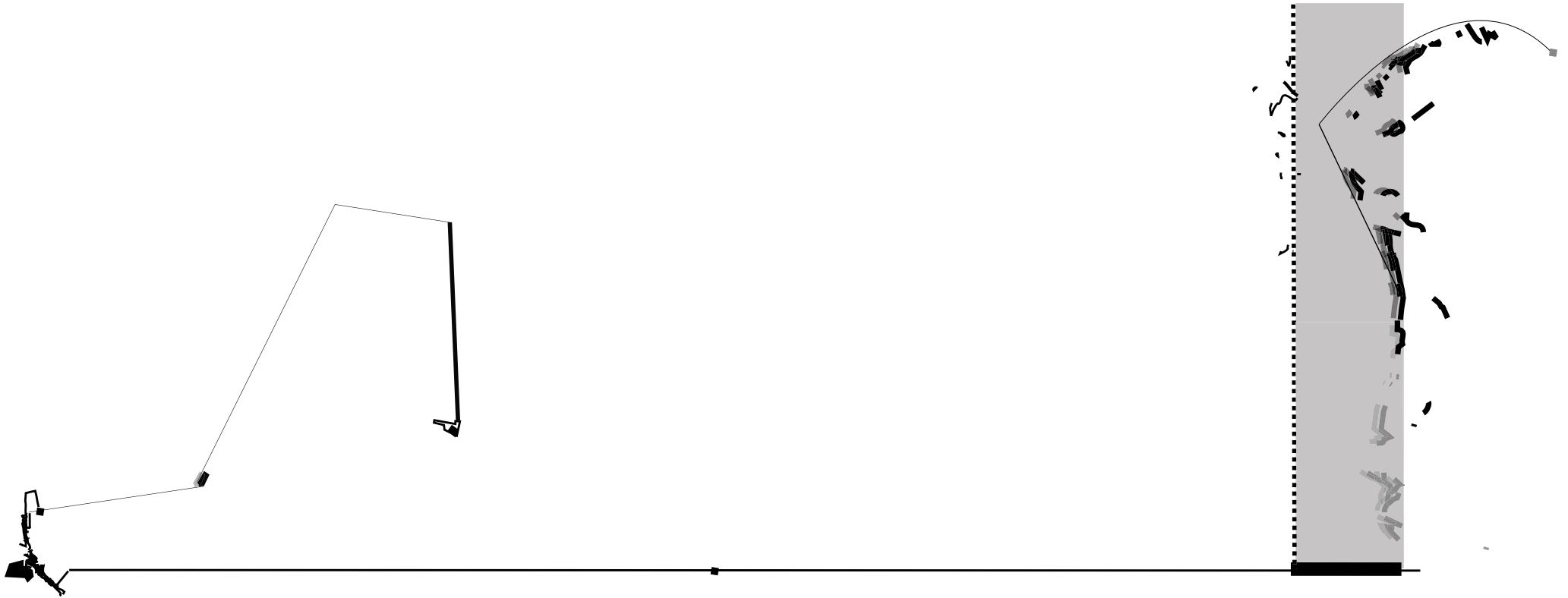

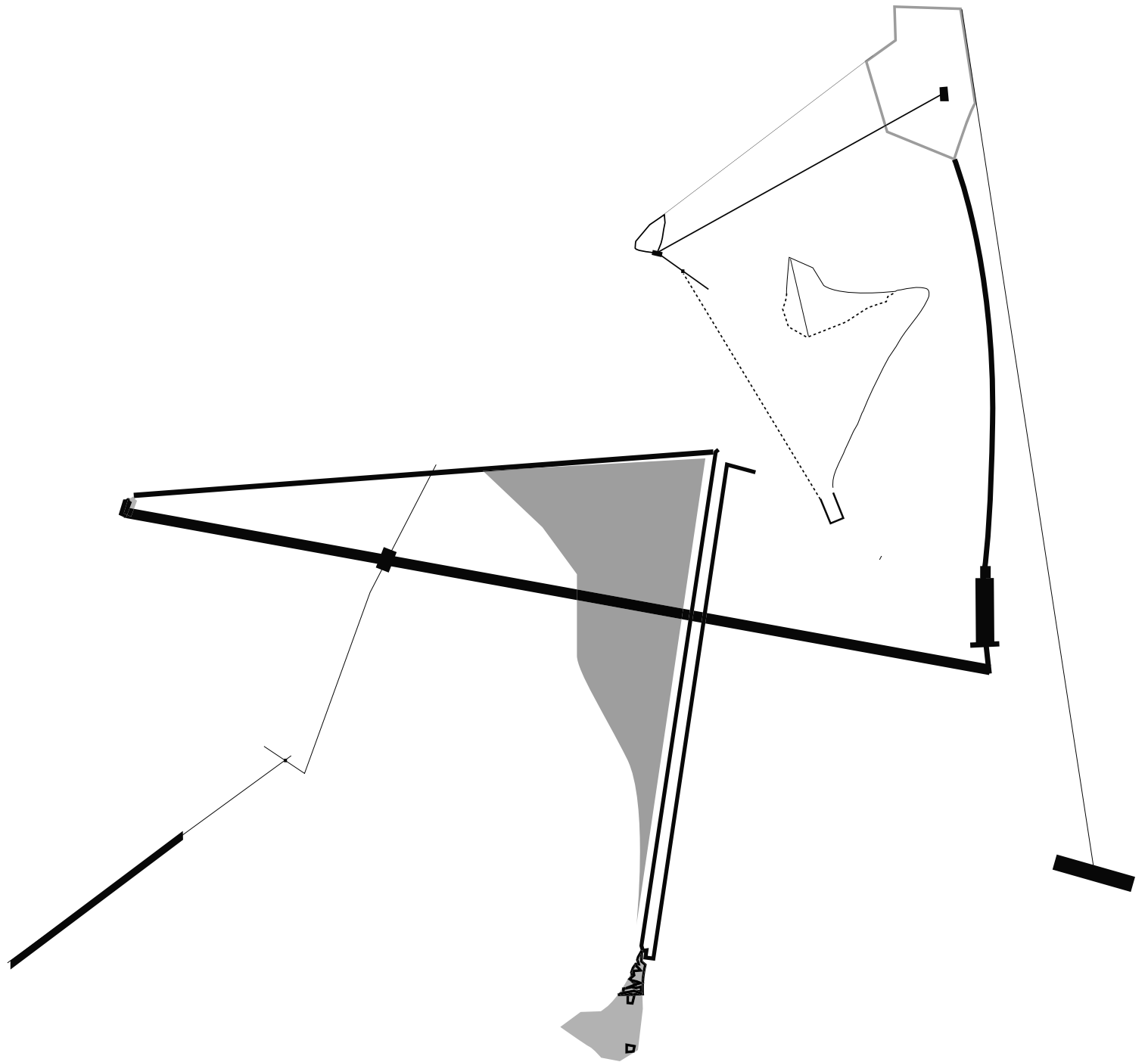

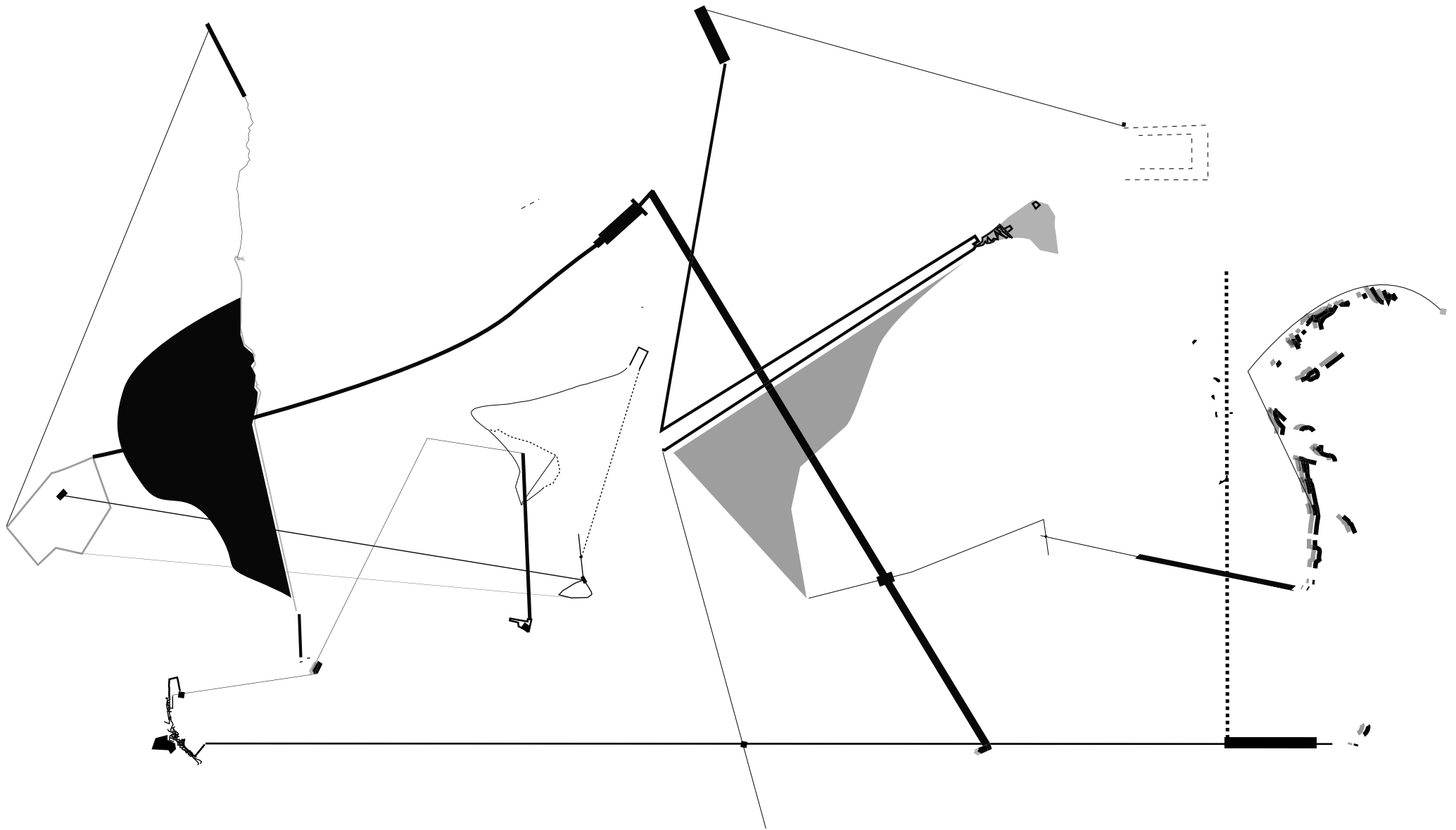

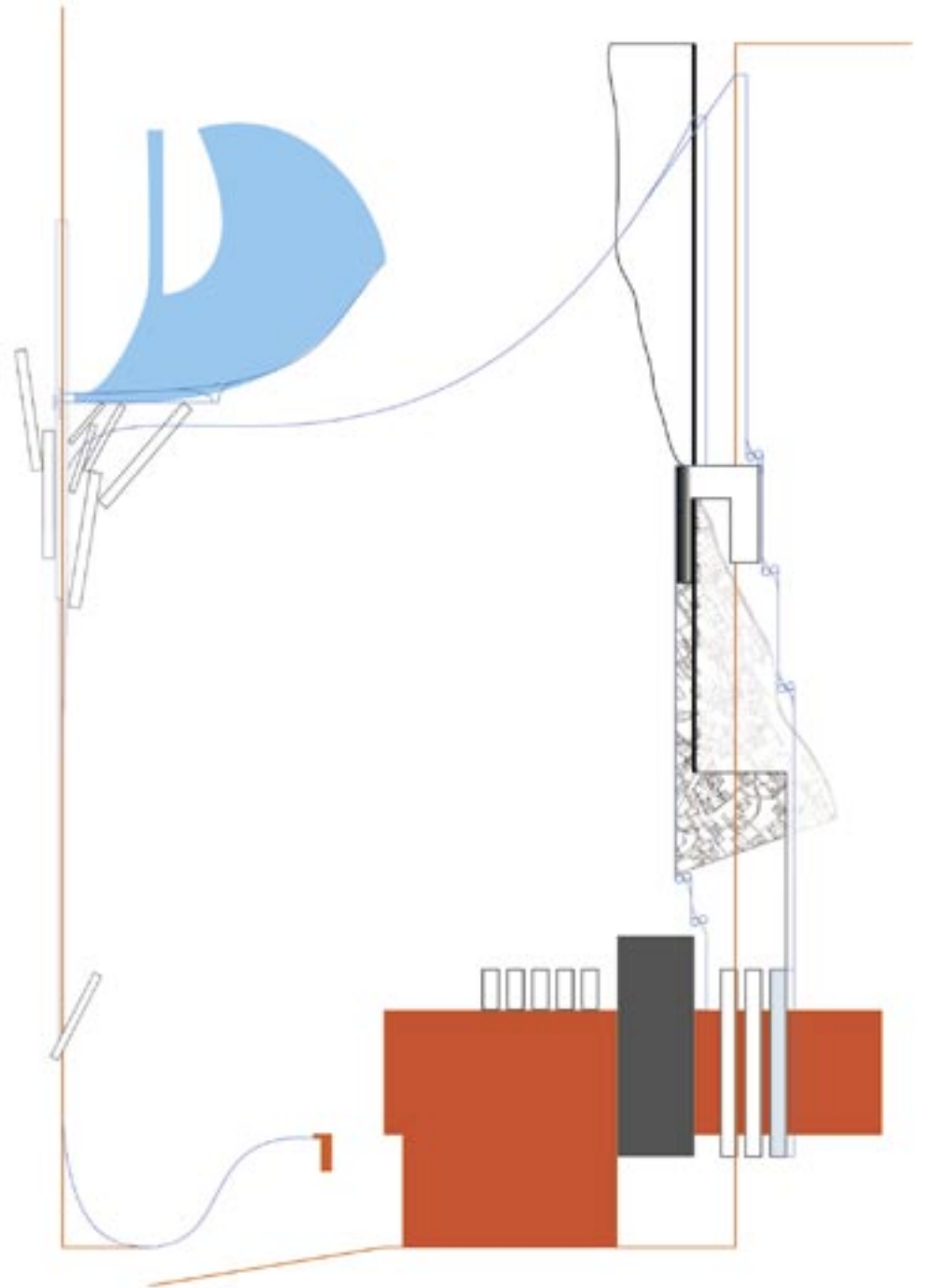

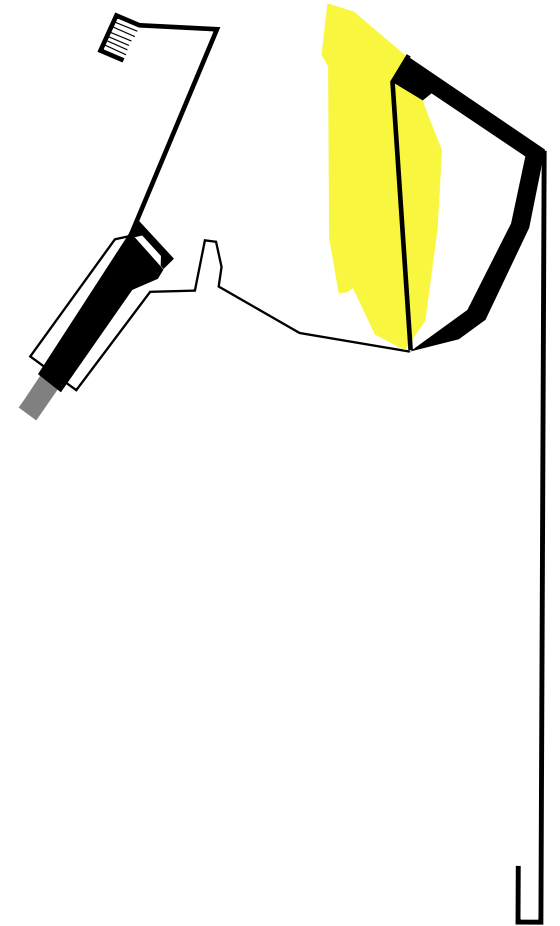
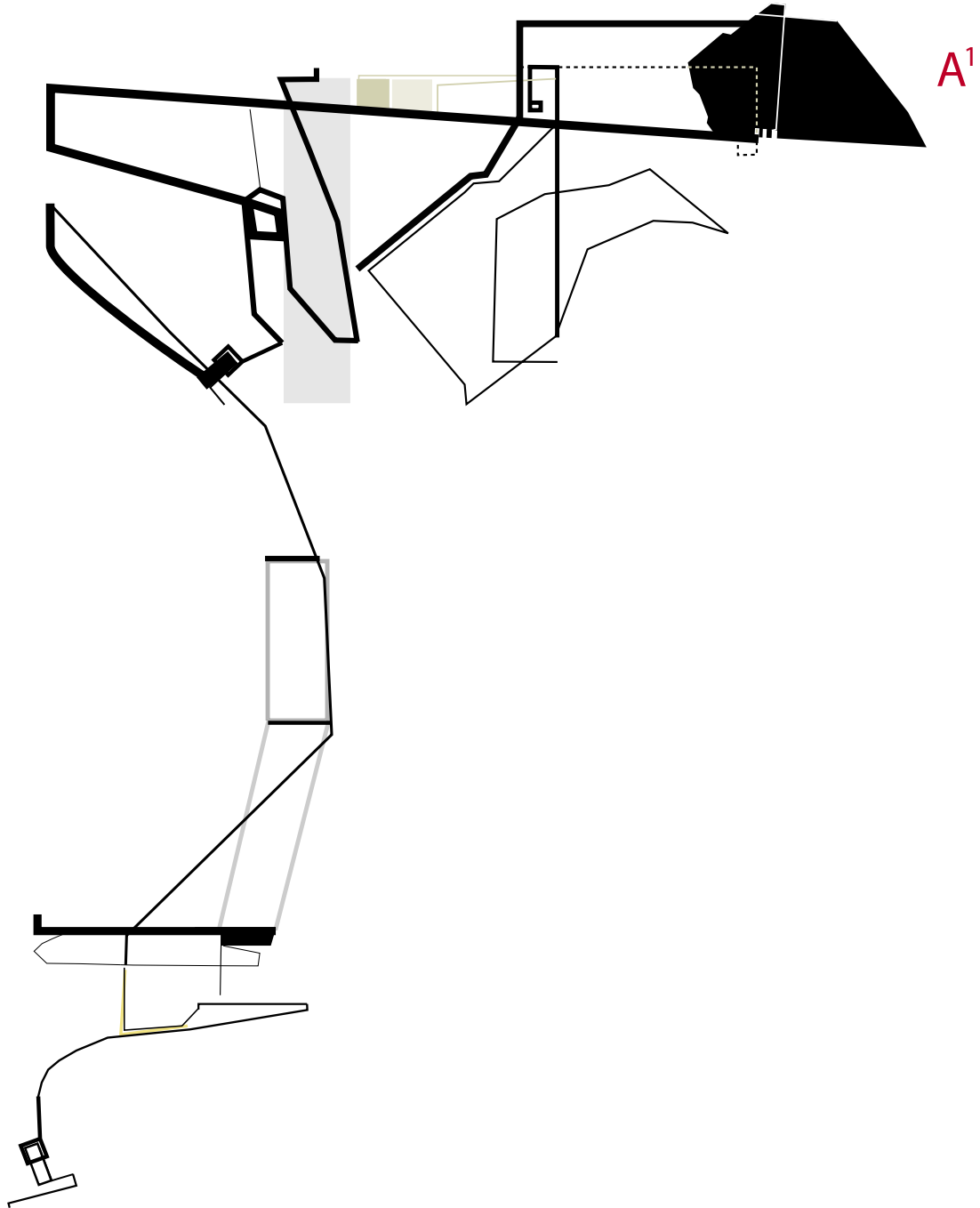

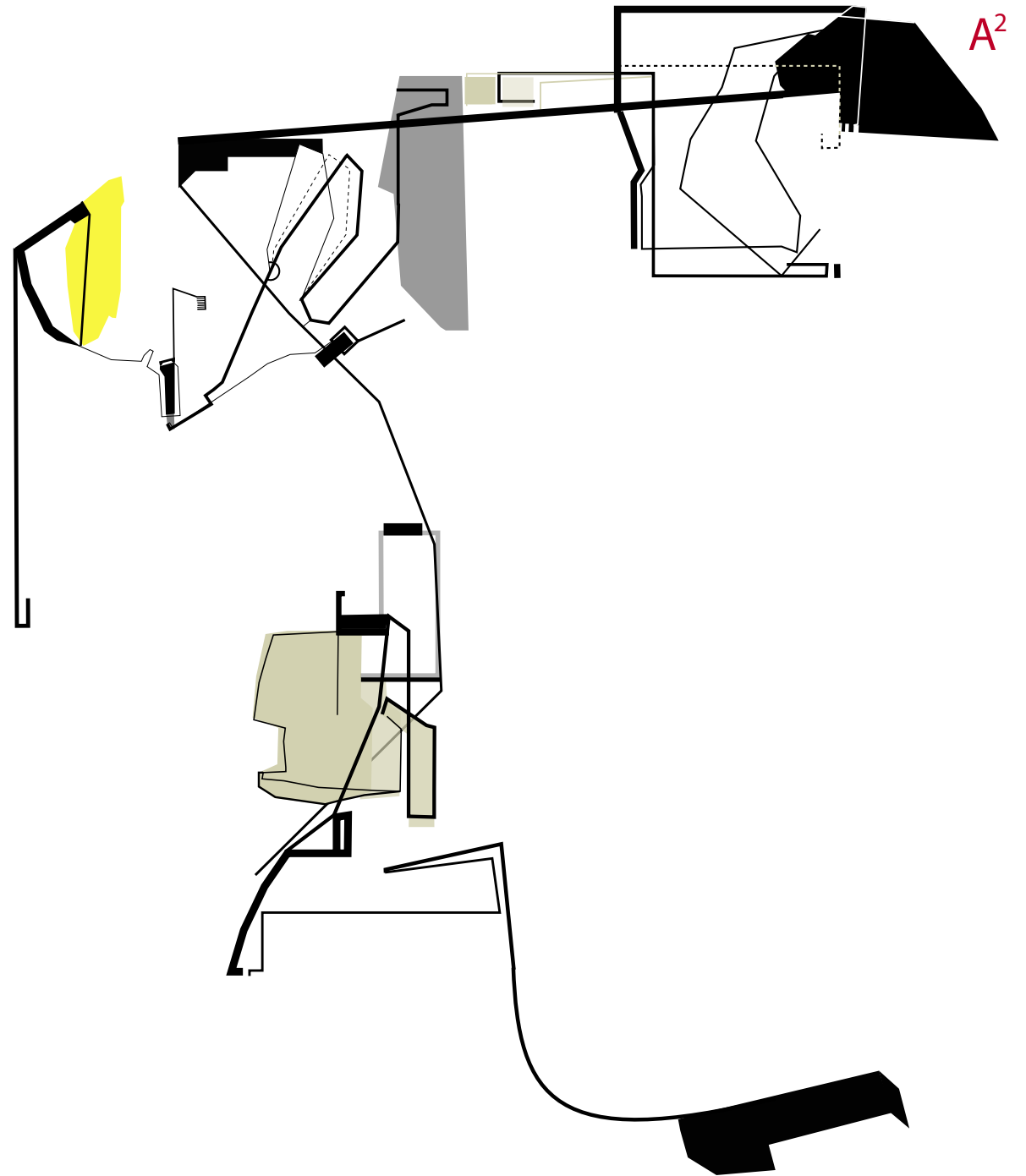

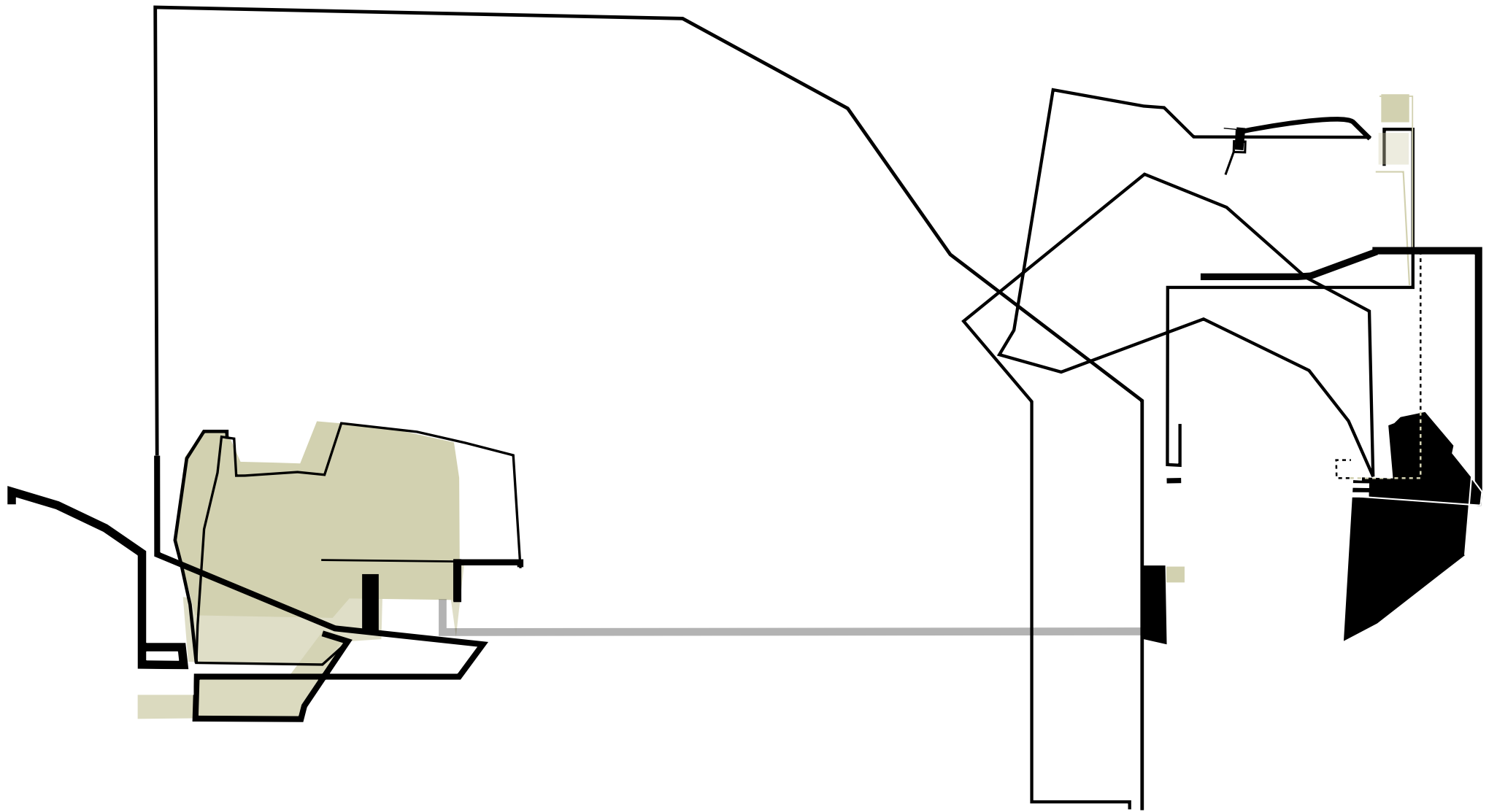

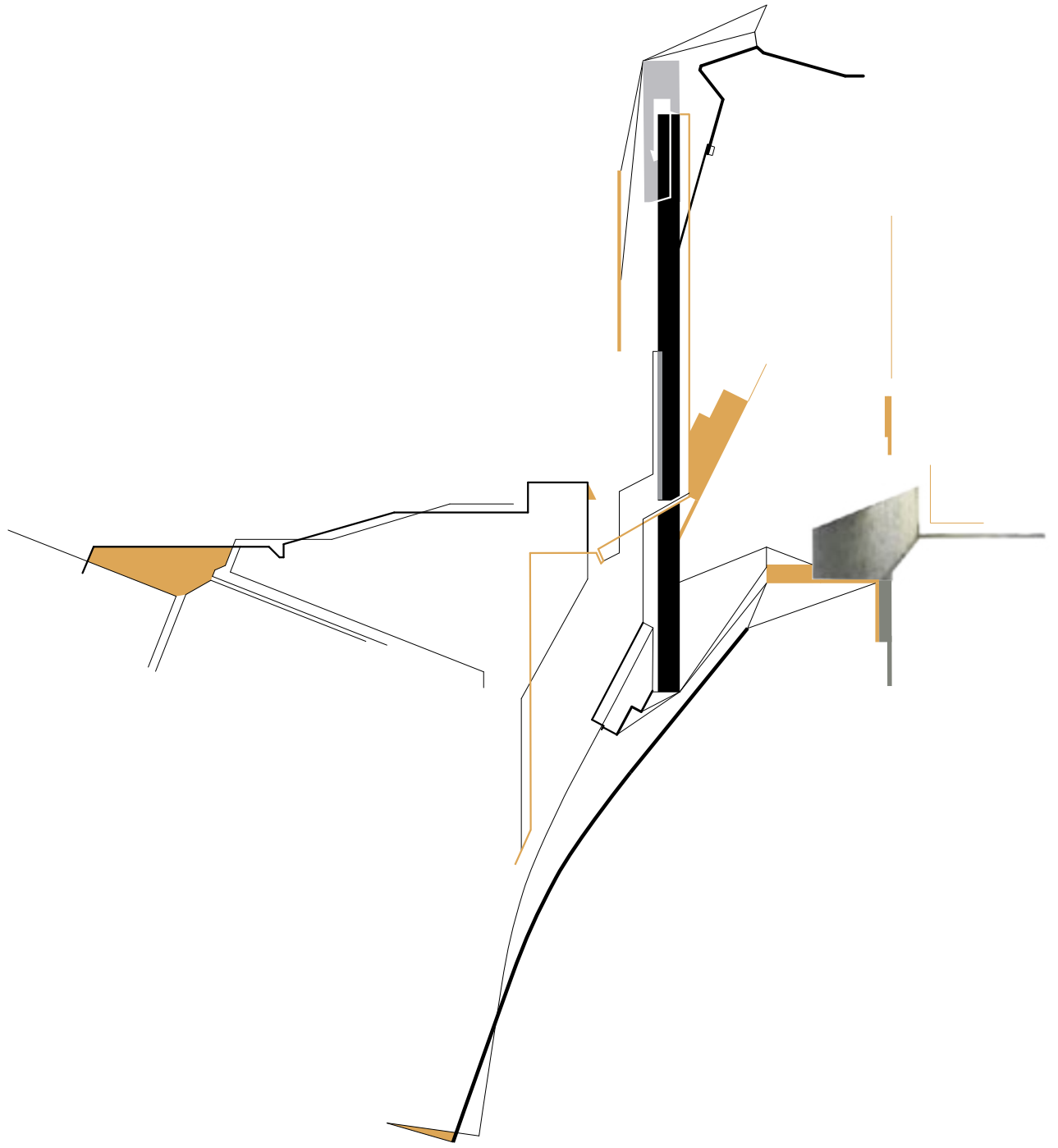

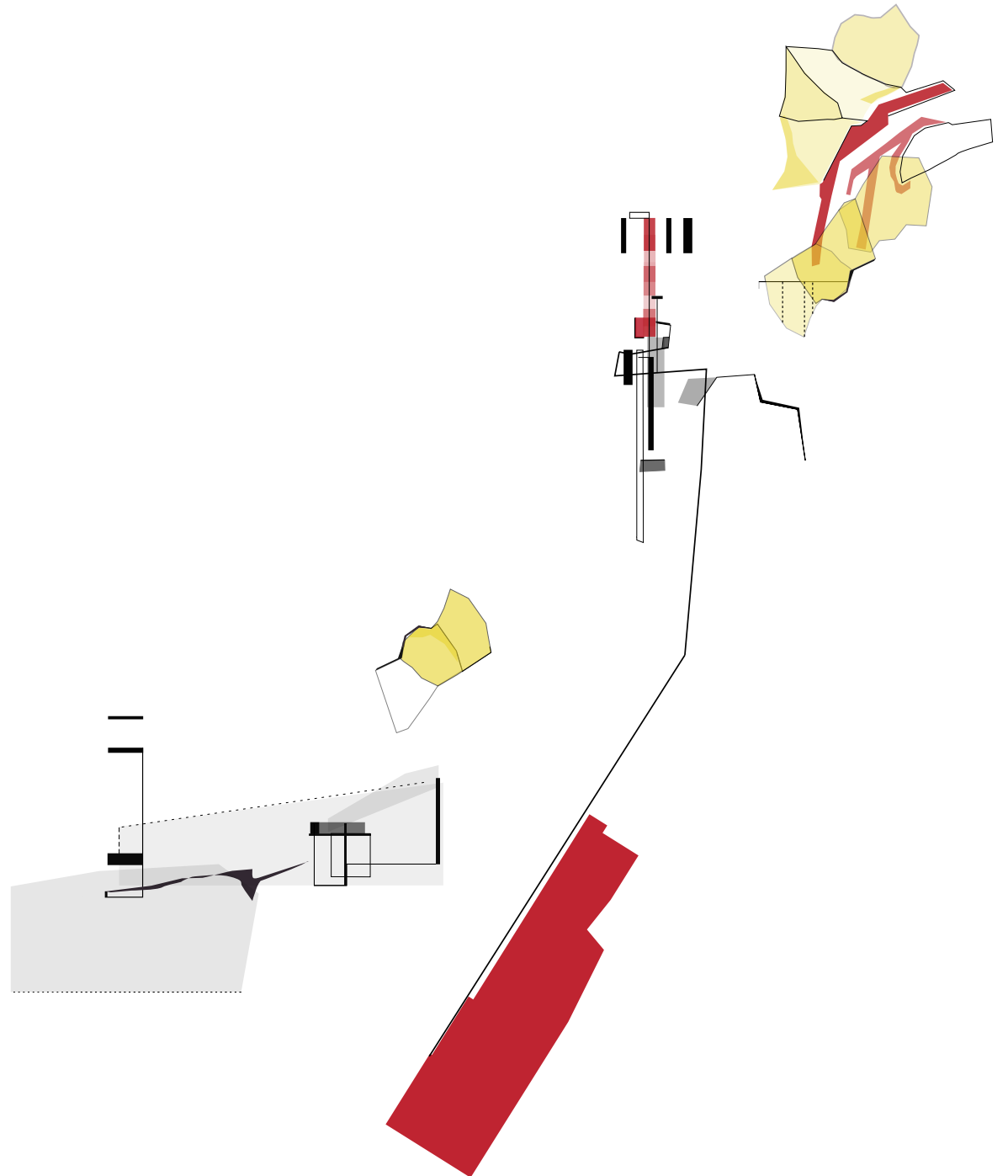

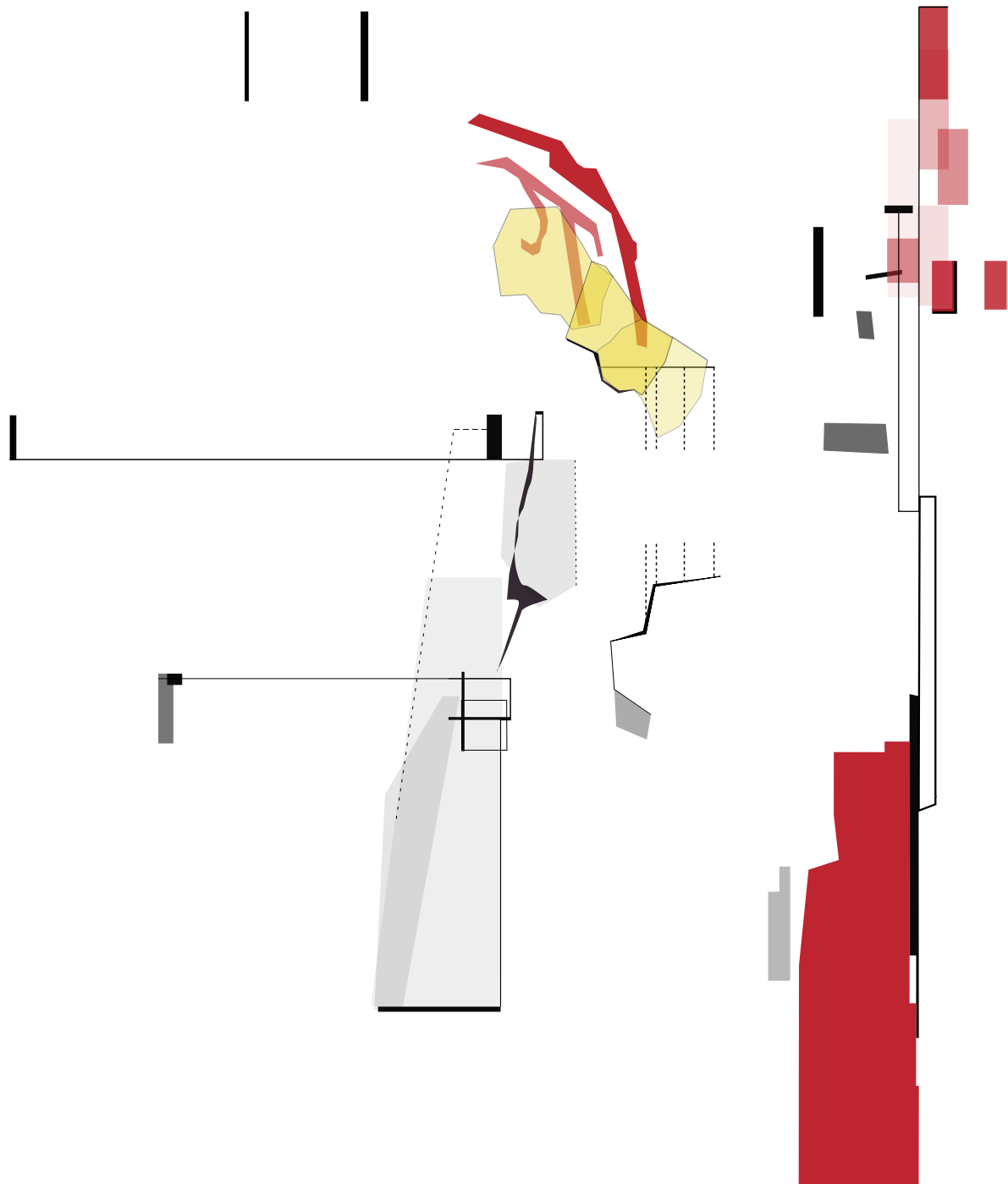

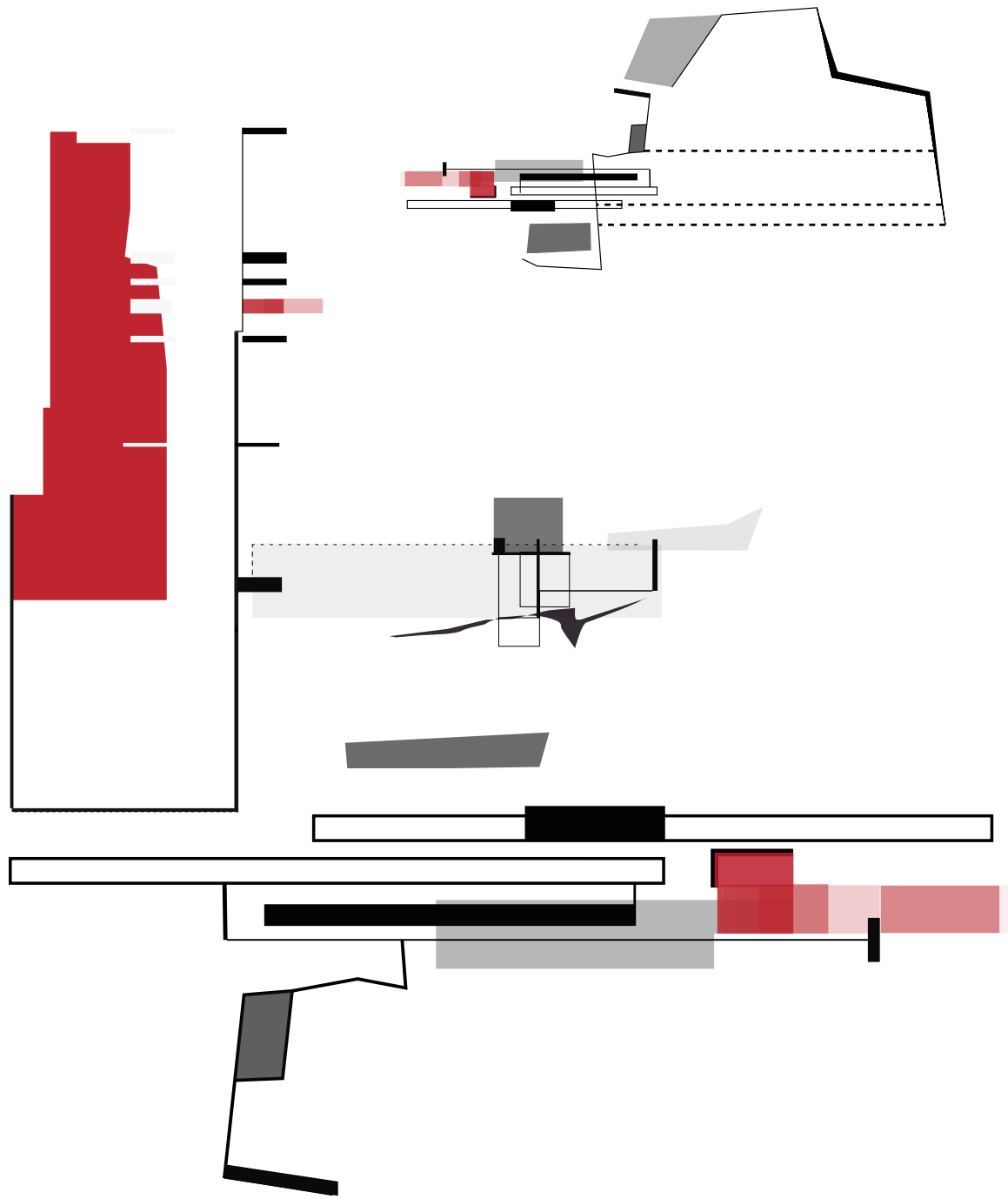

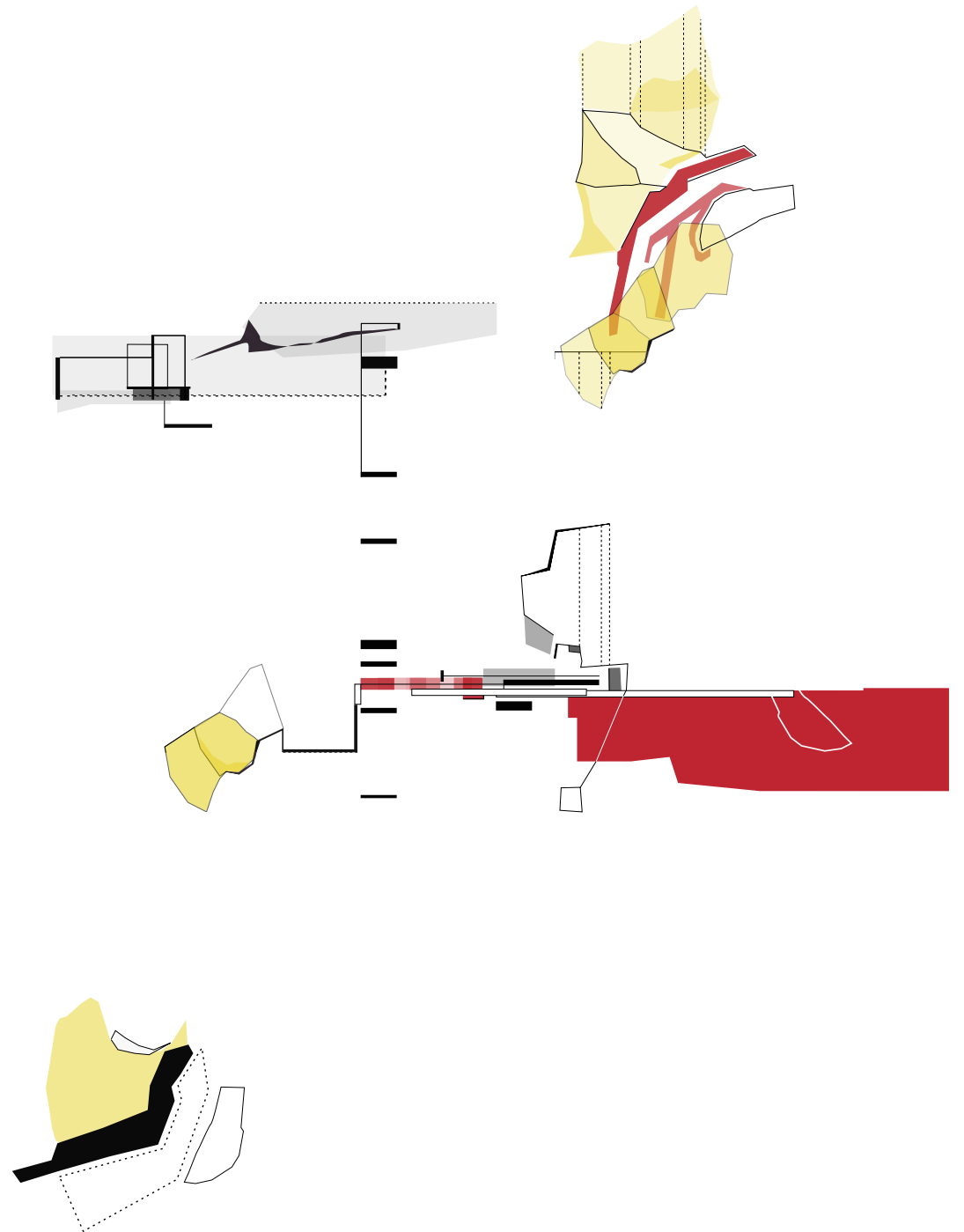

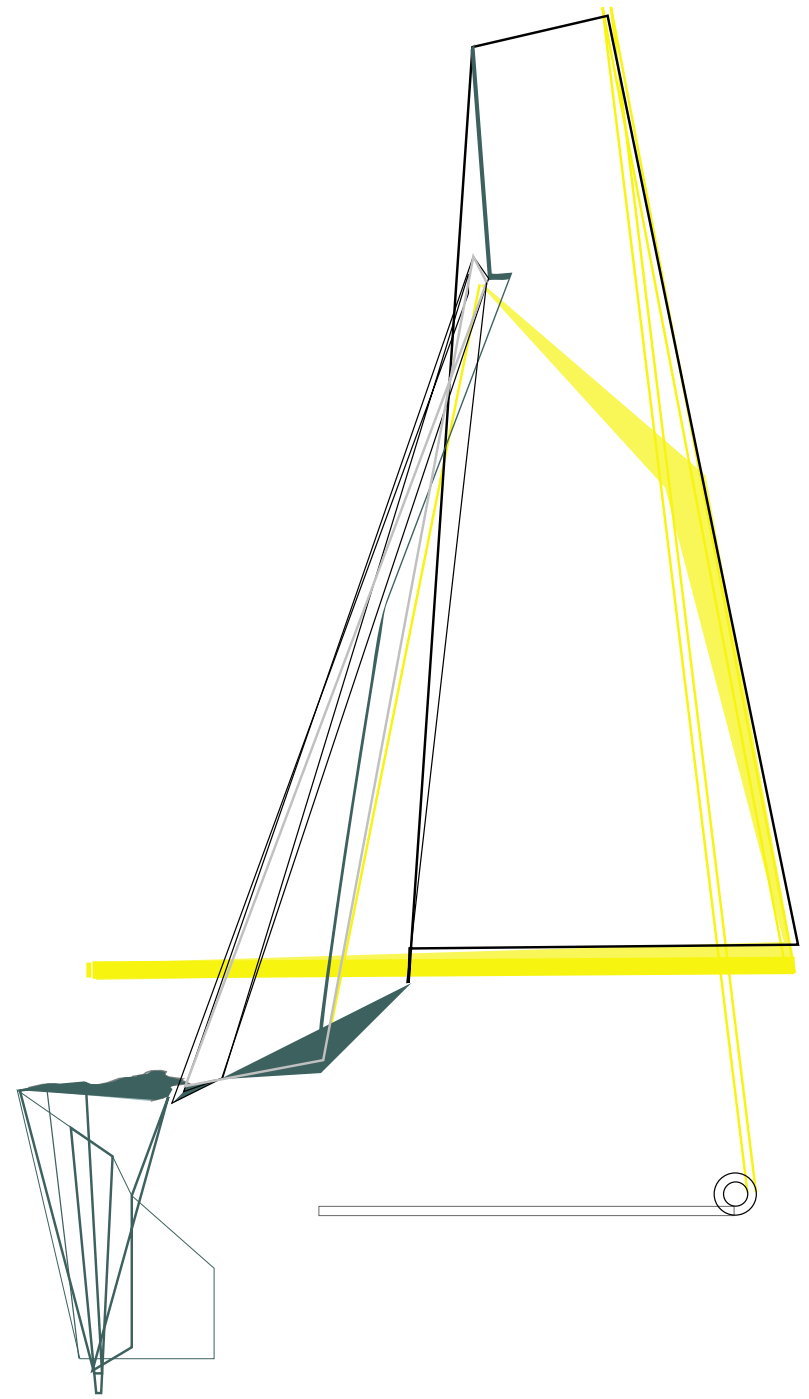
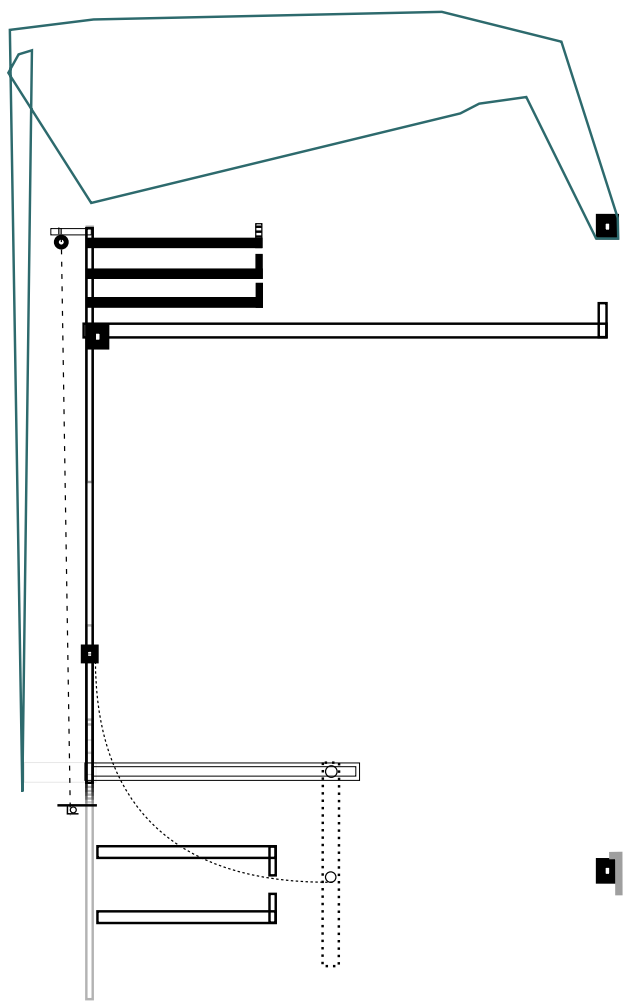

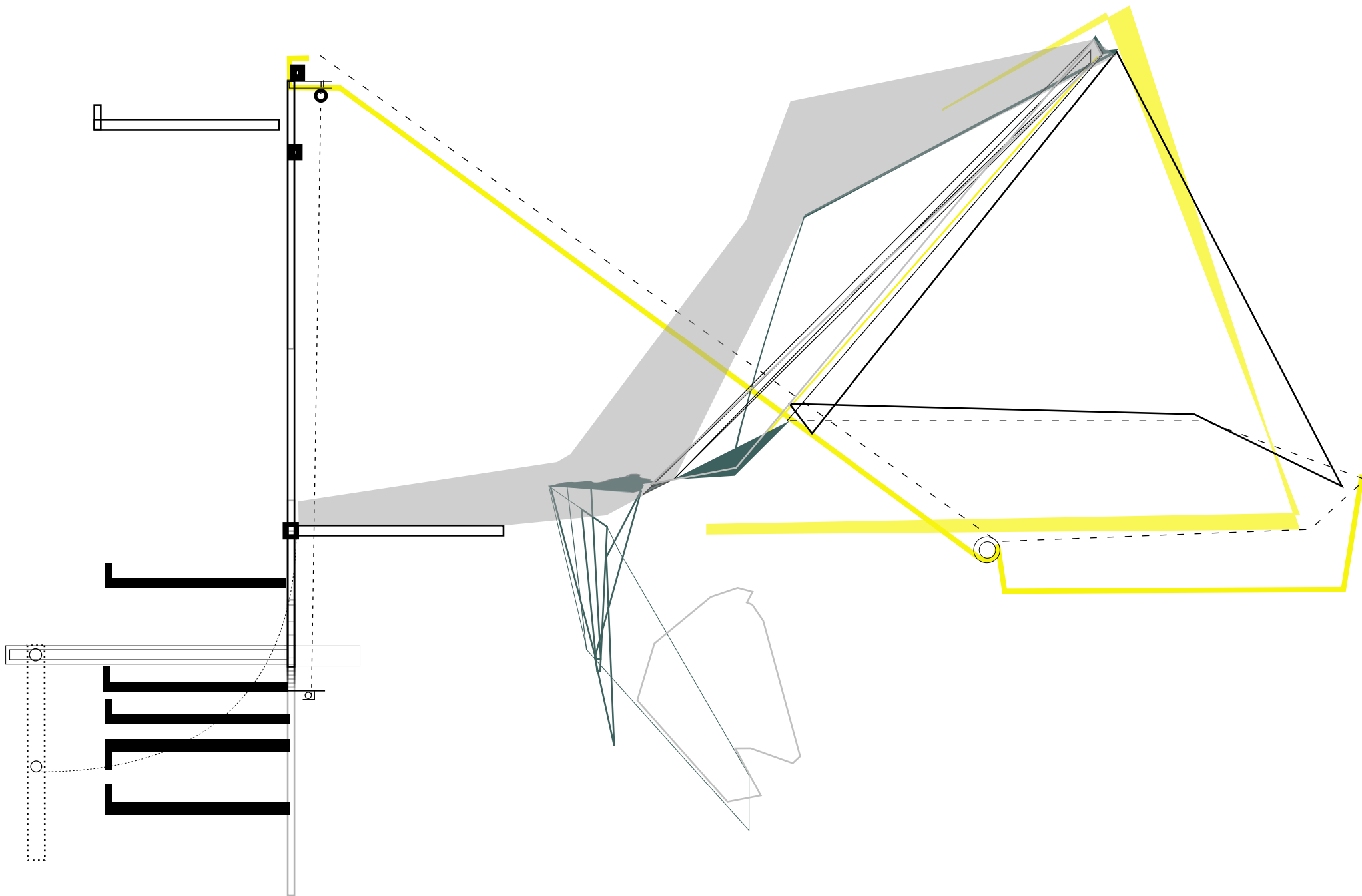

Mangfoldigheder

forelæsning af Kasper Nefer Olsen

Klik for at høre

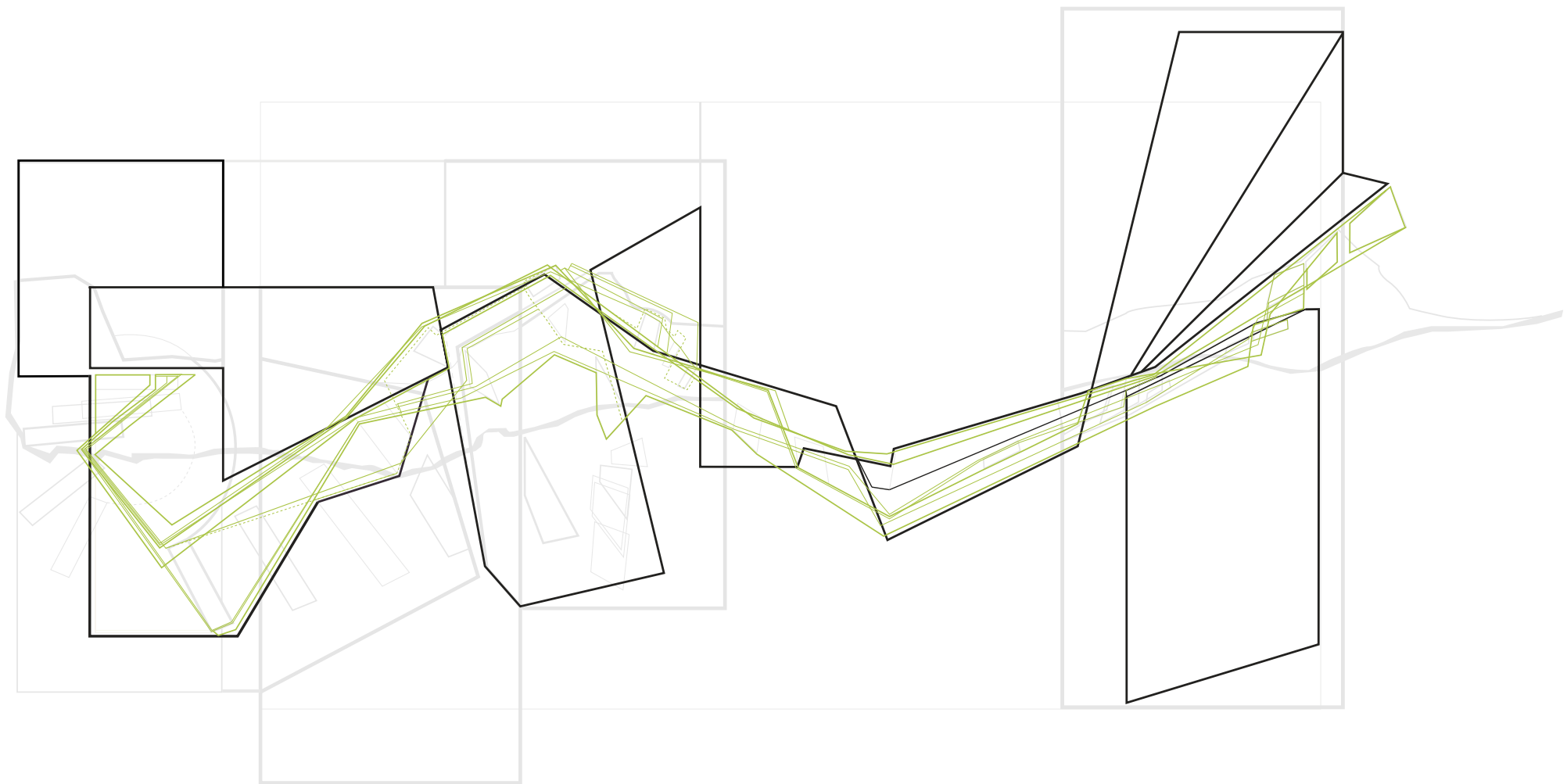

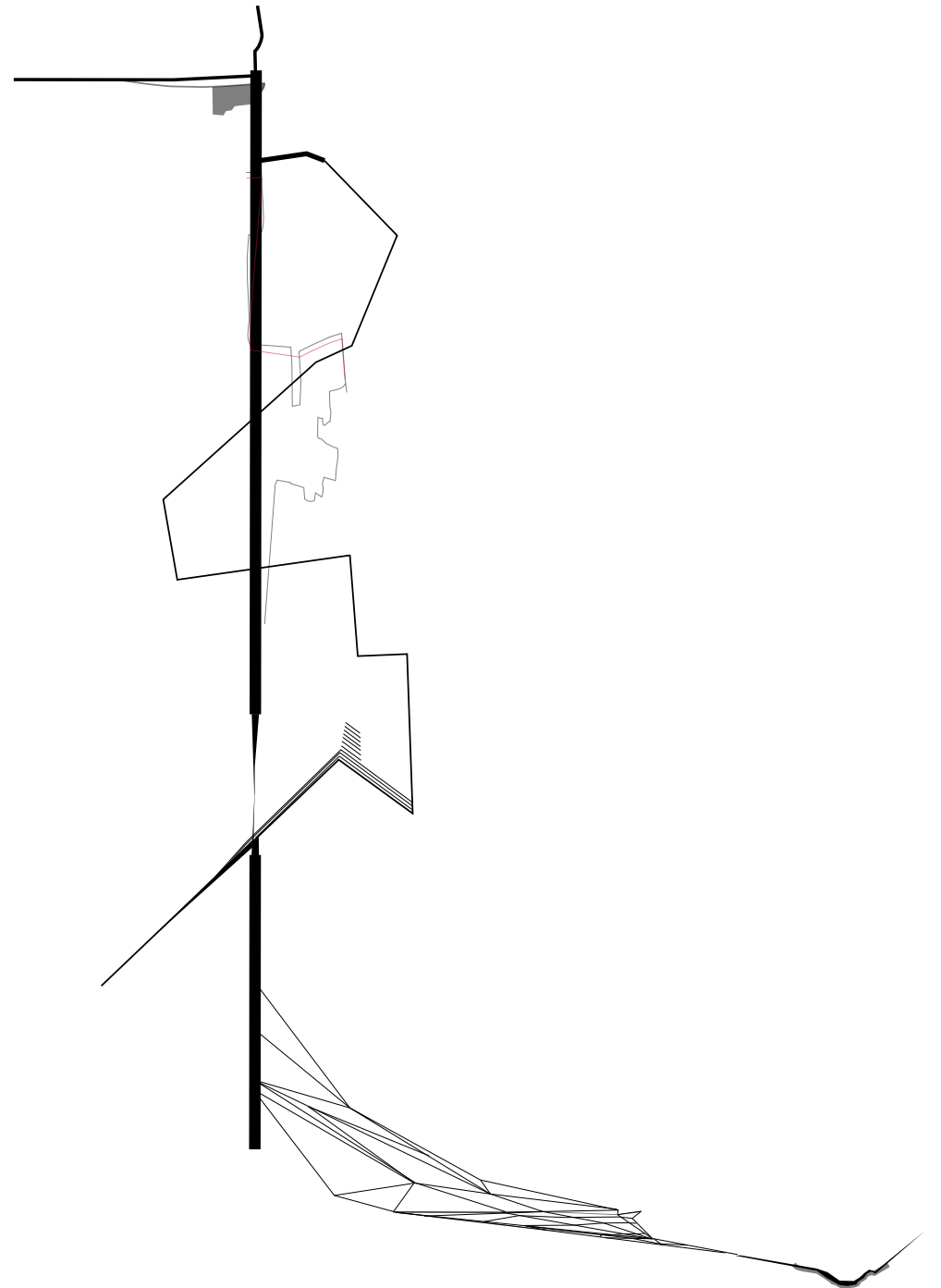

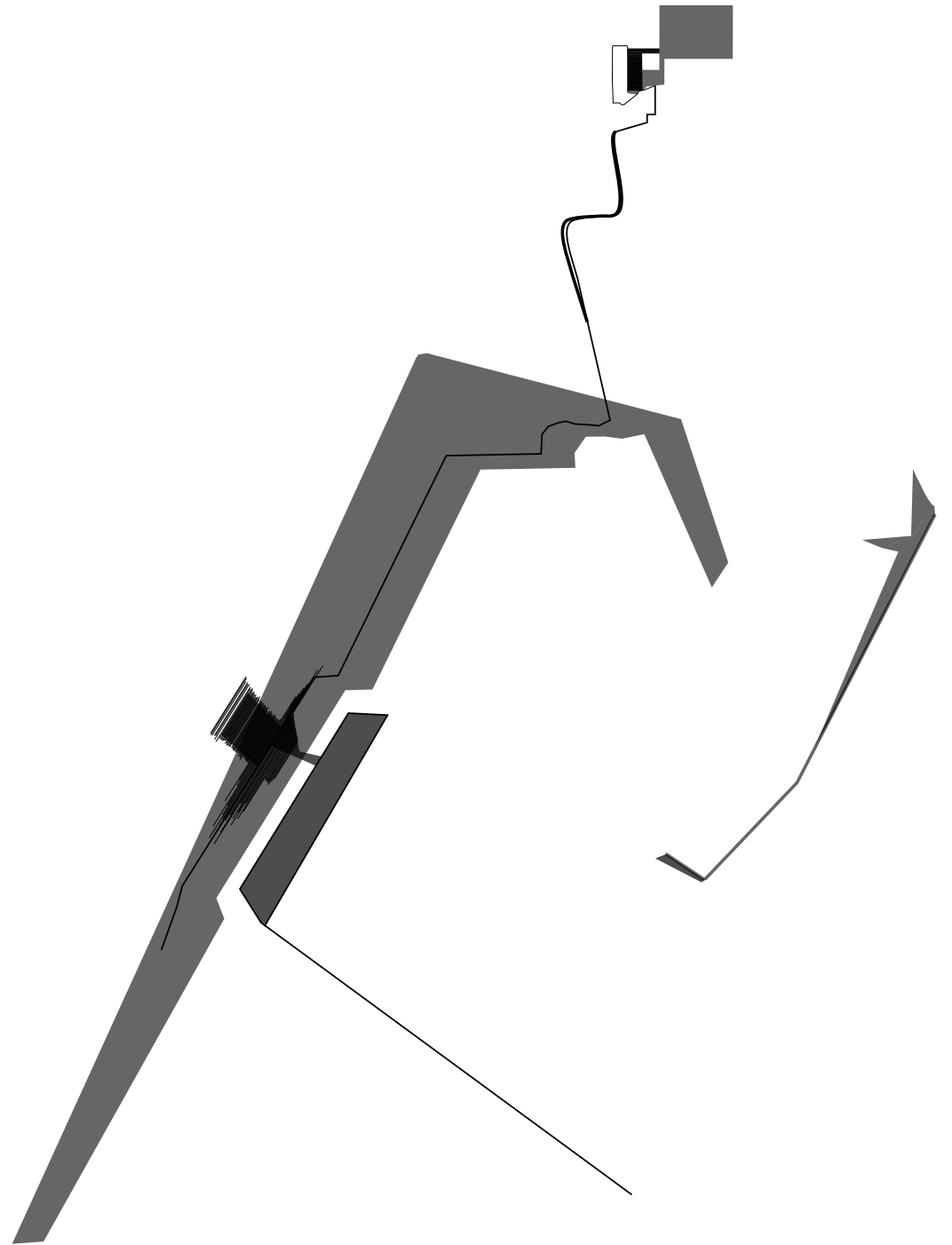



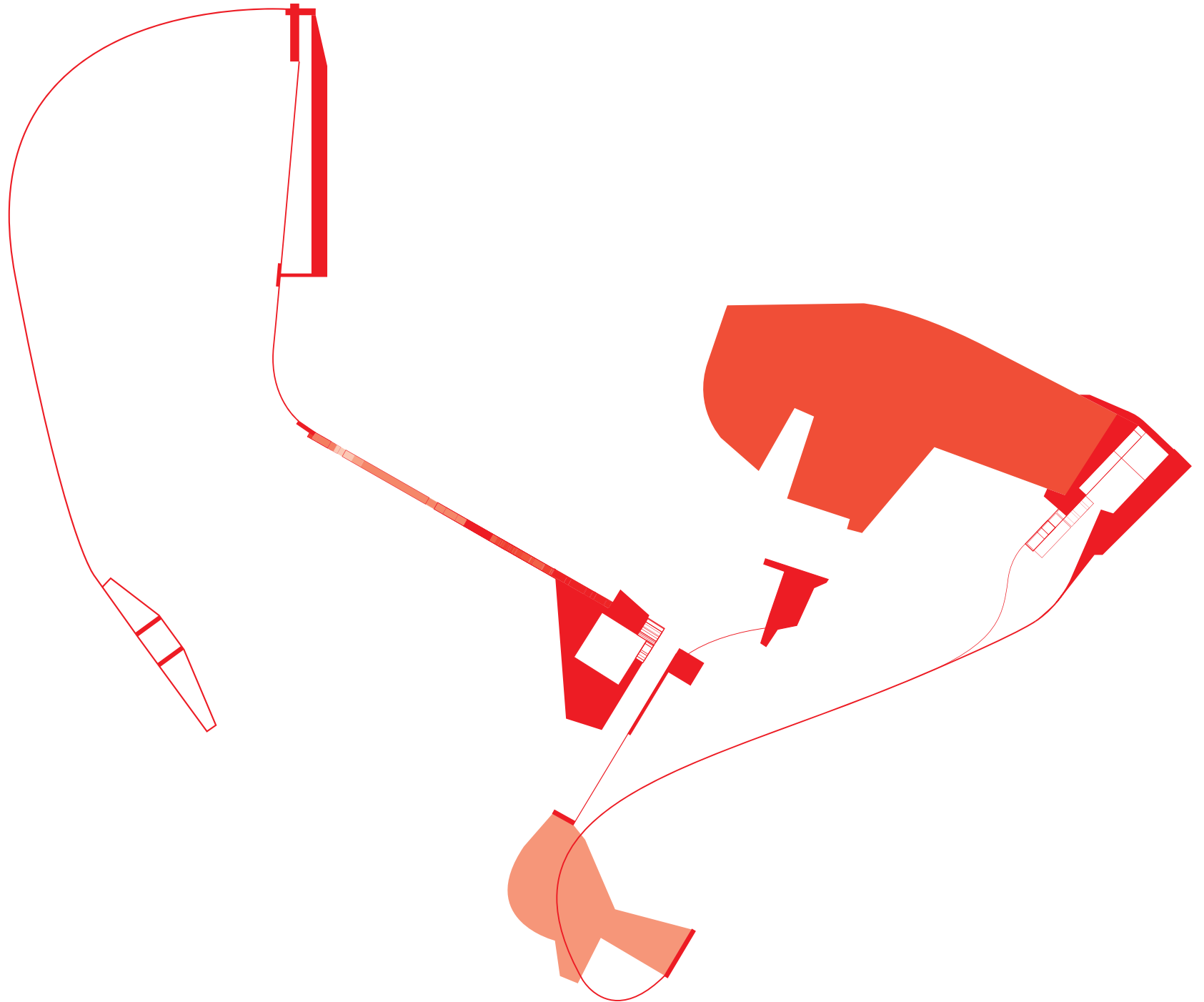

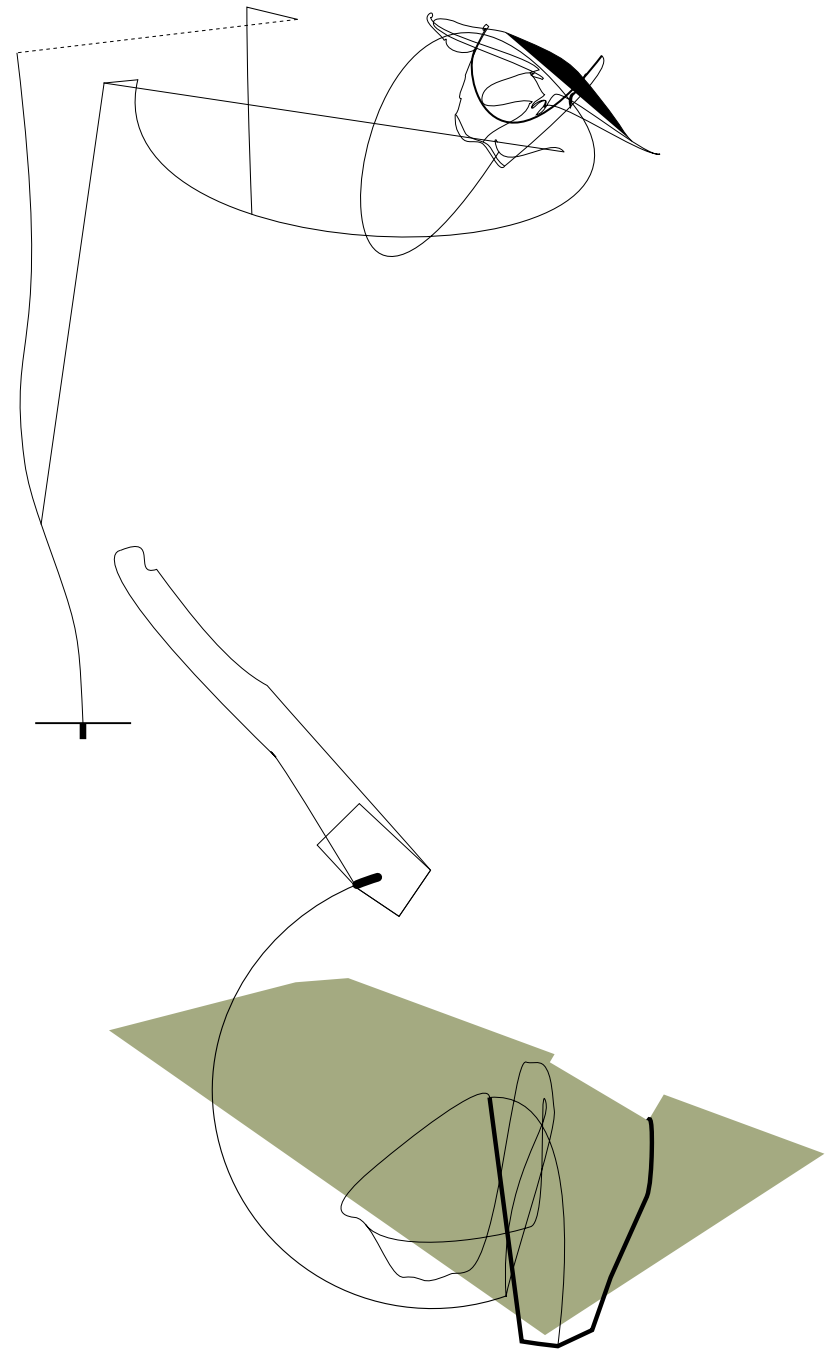

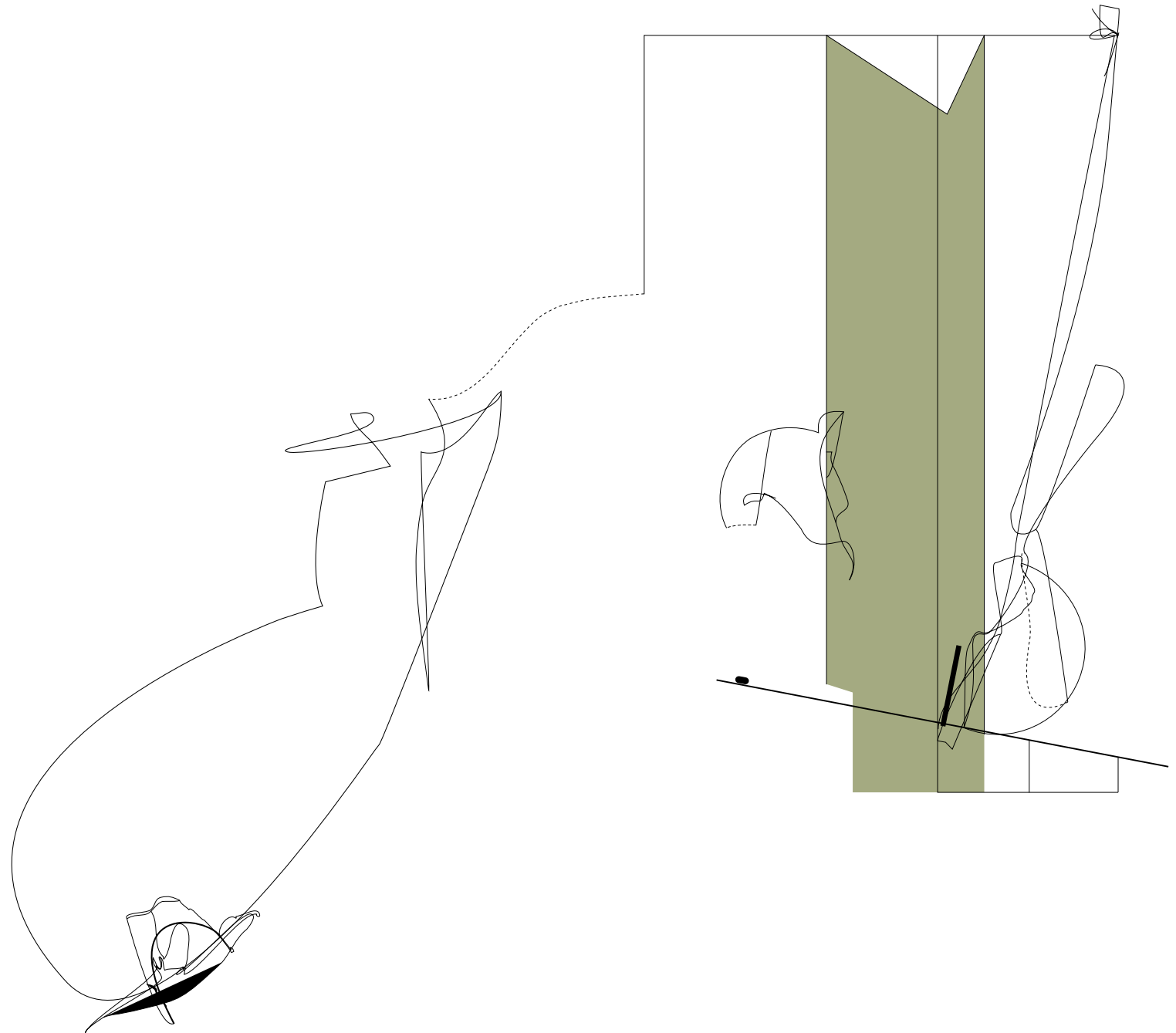

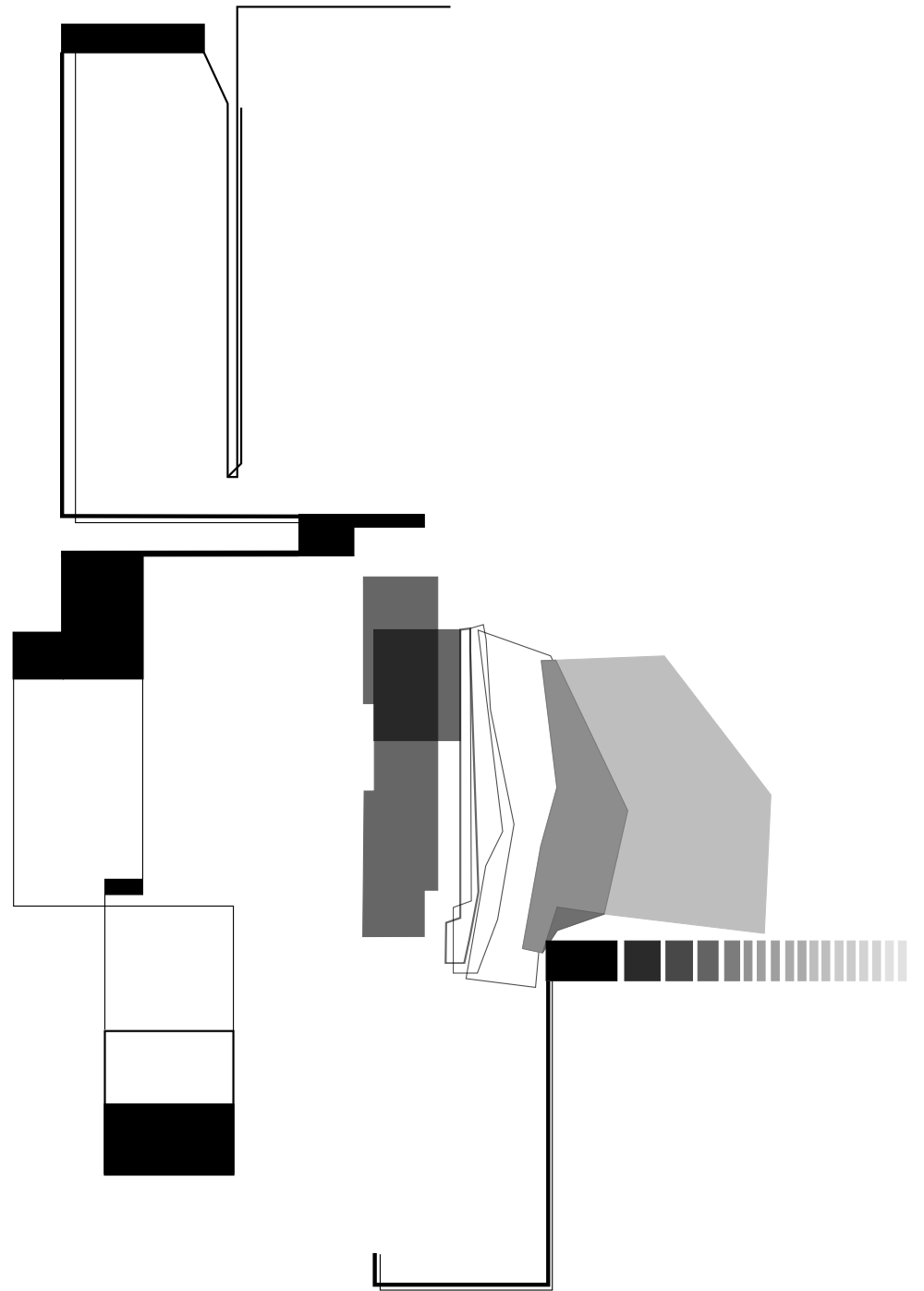

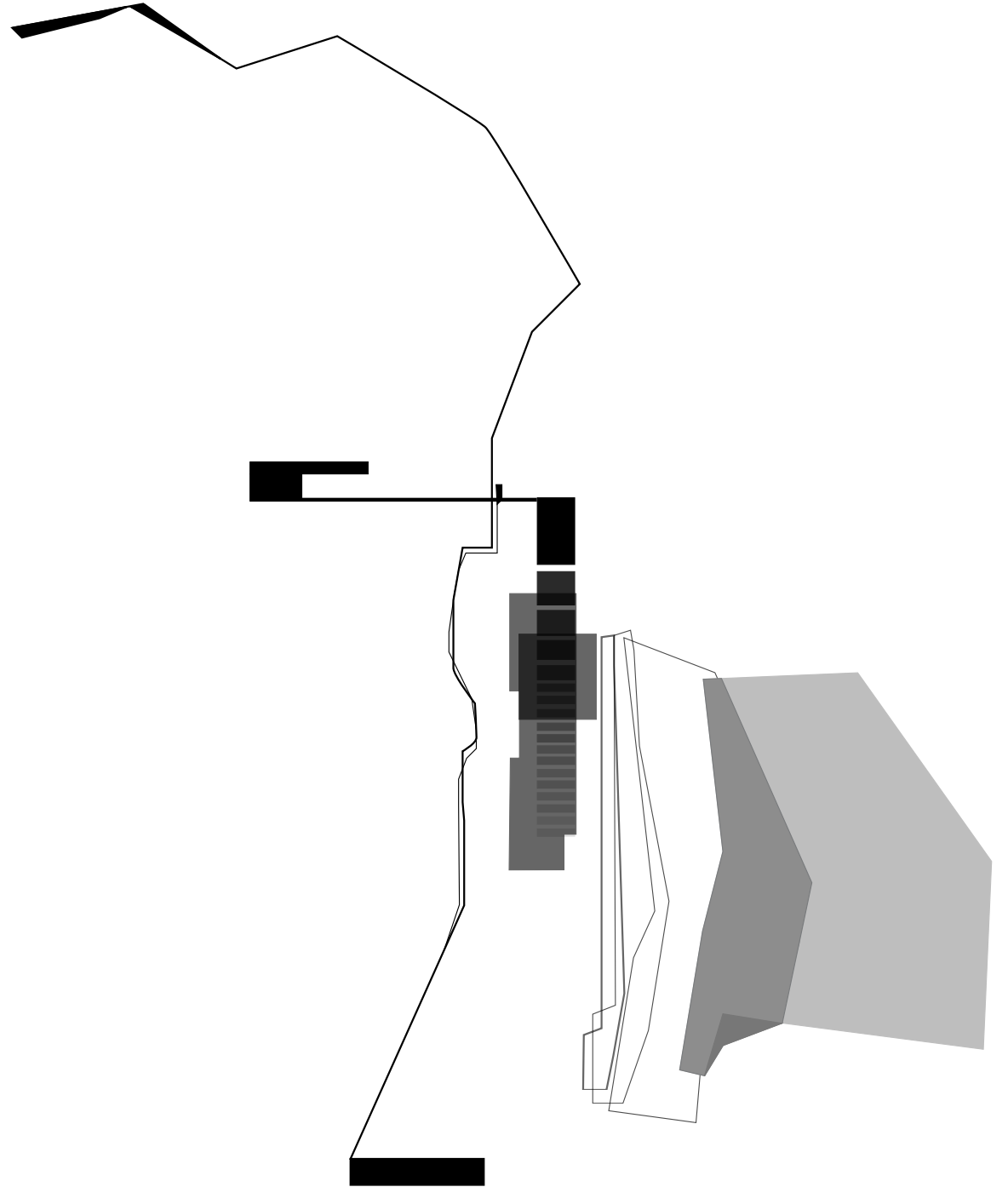

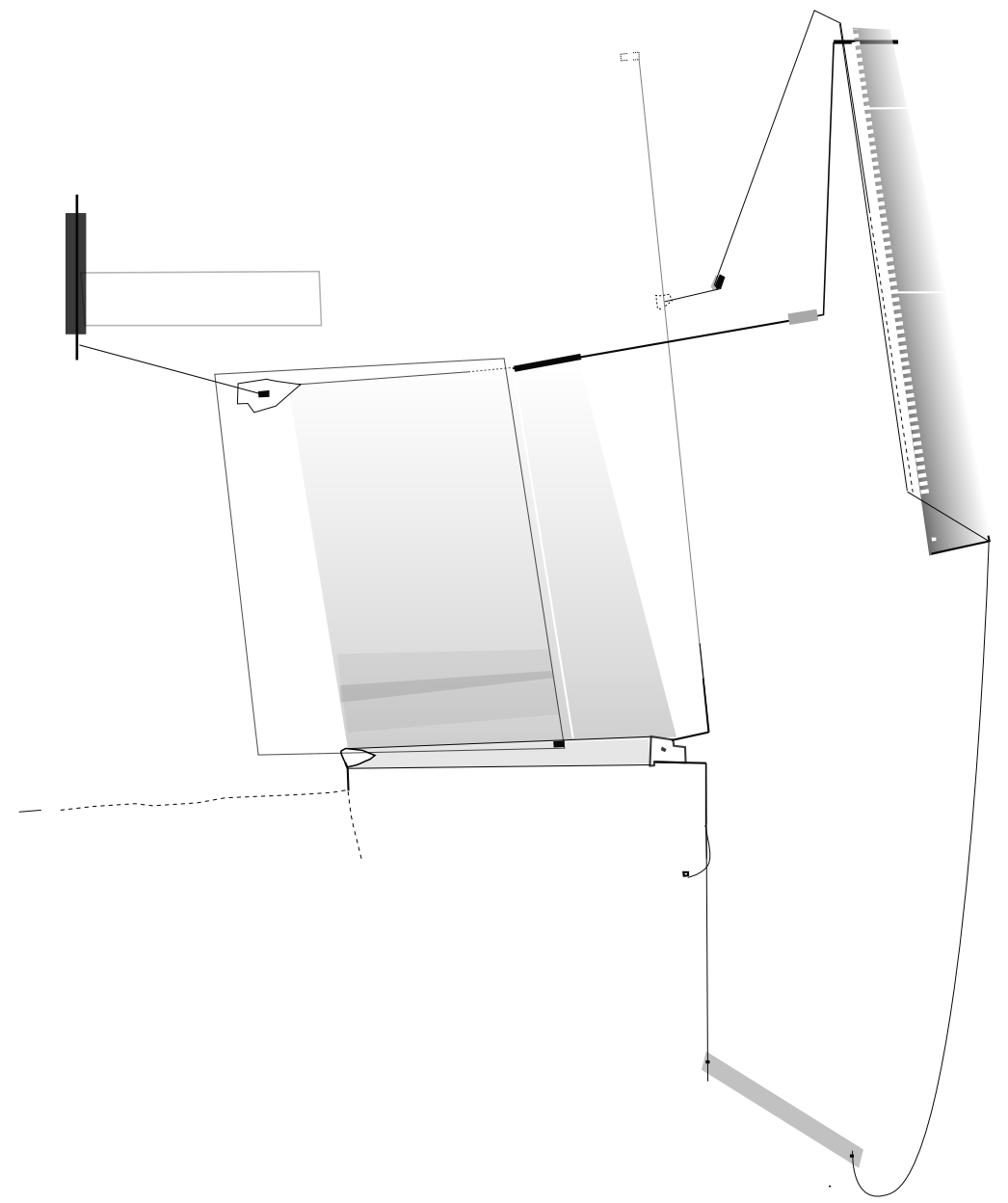

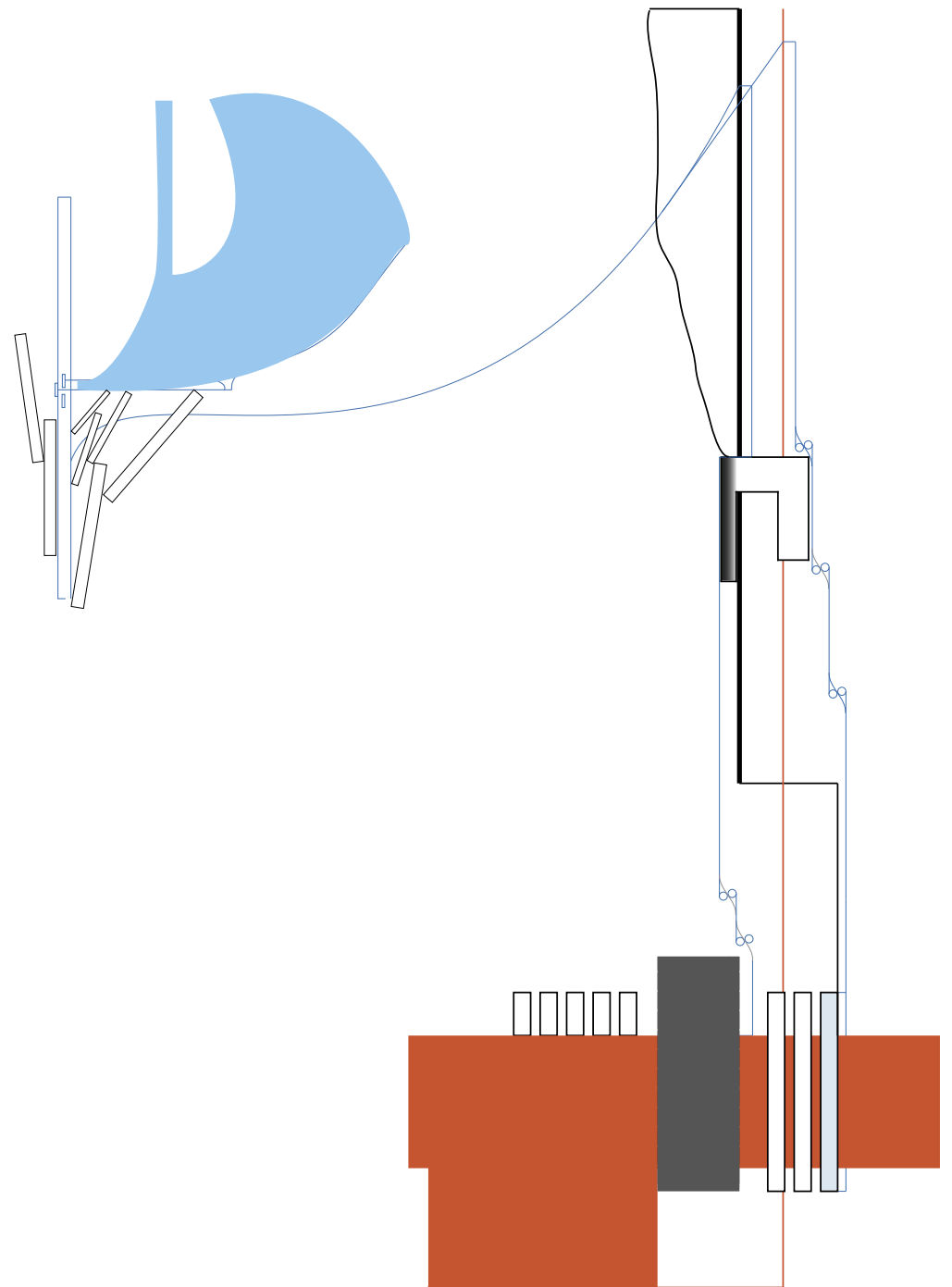

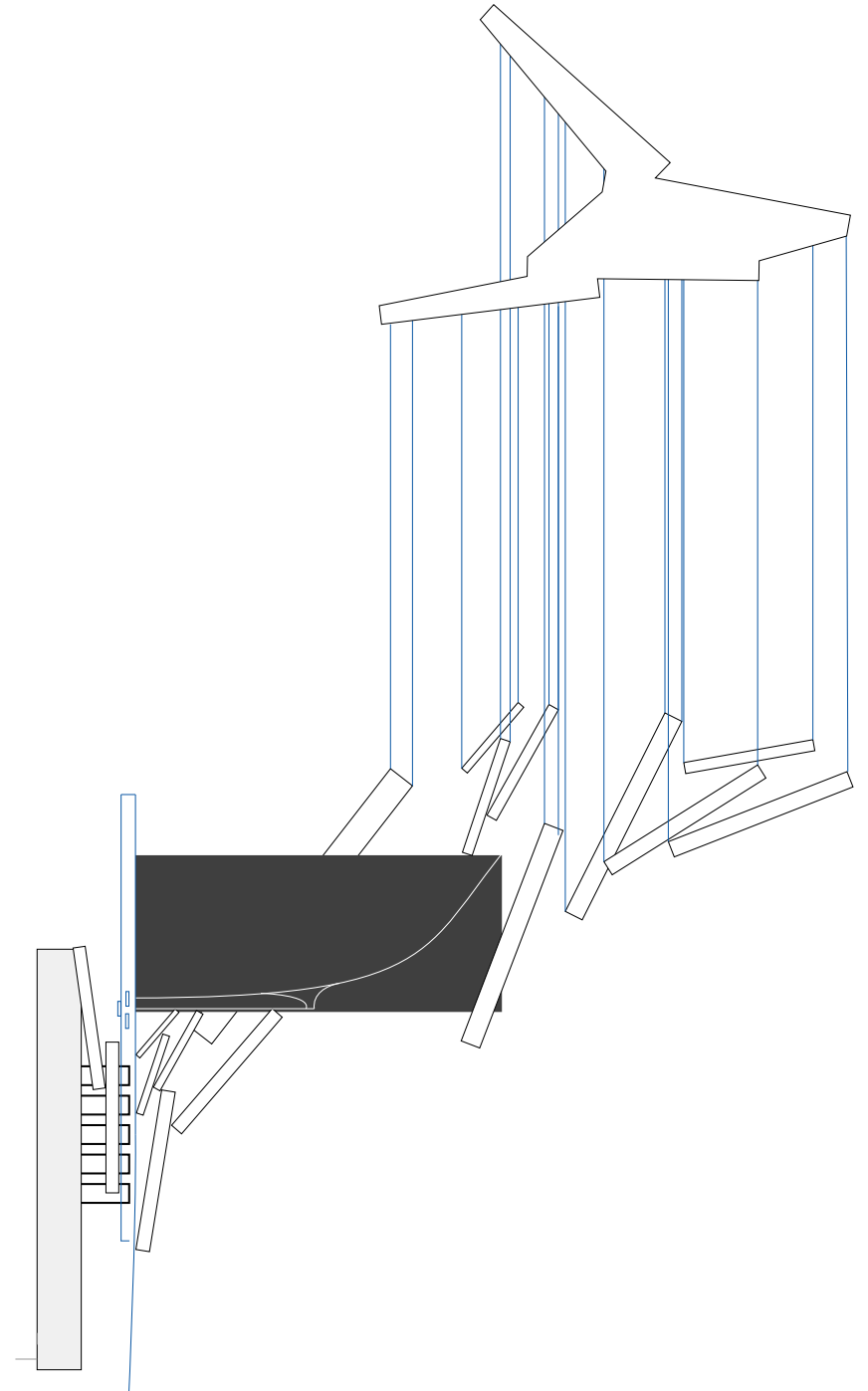

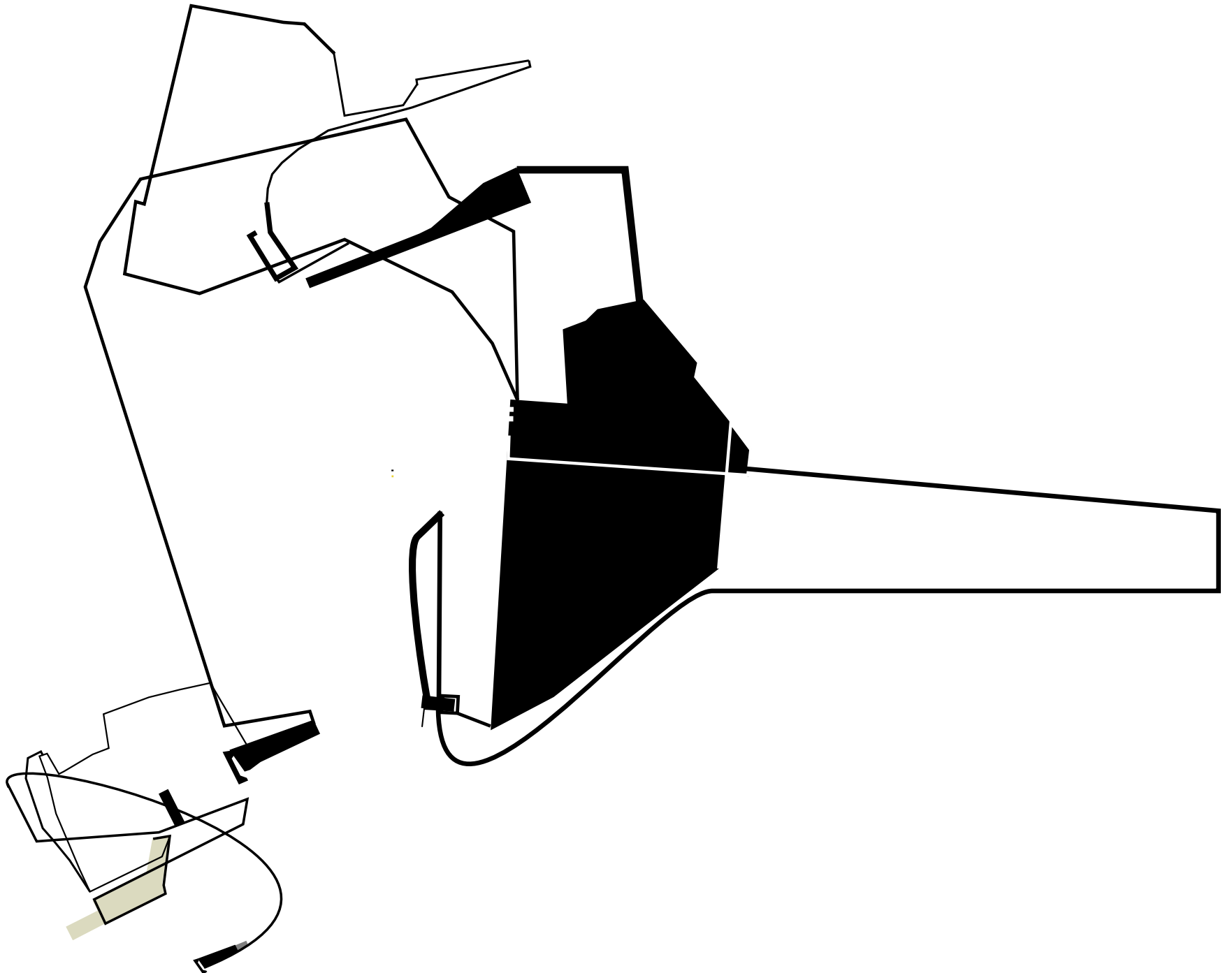

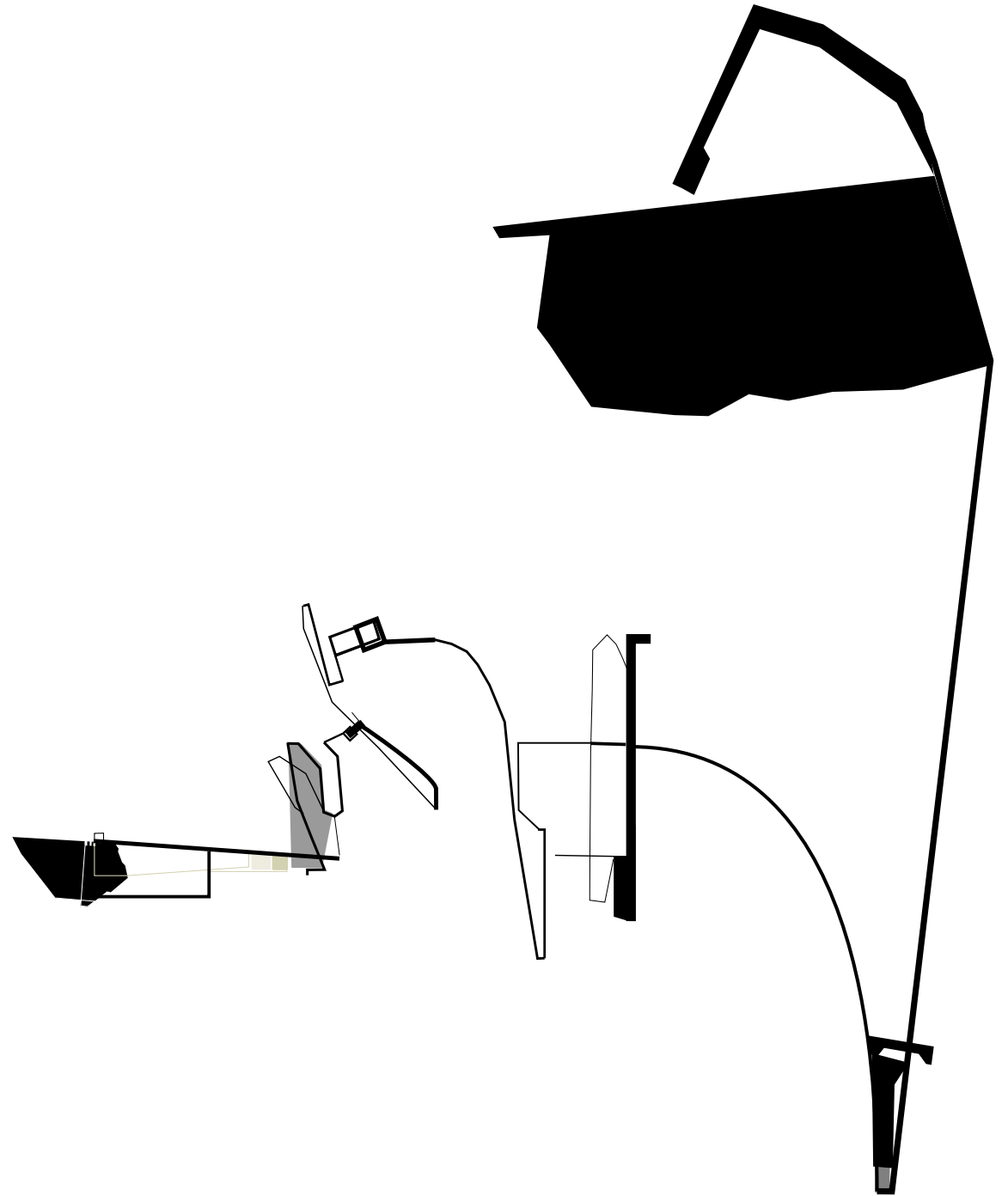

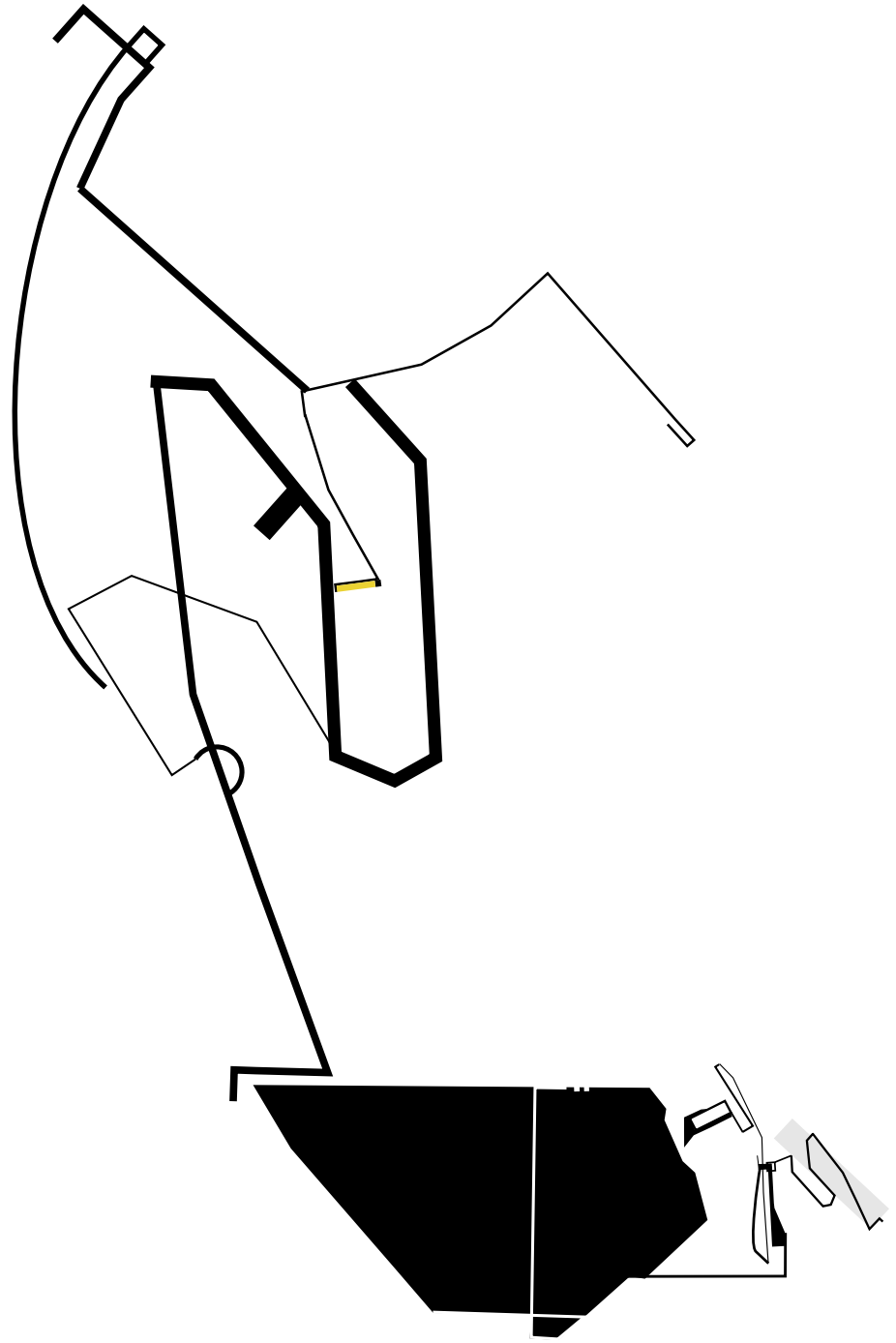

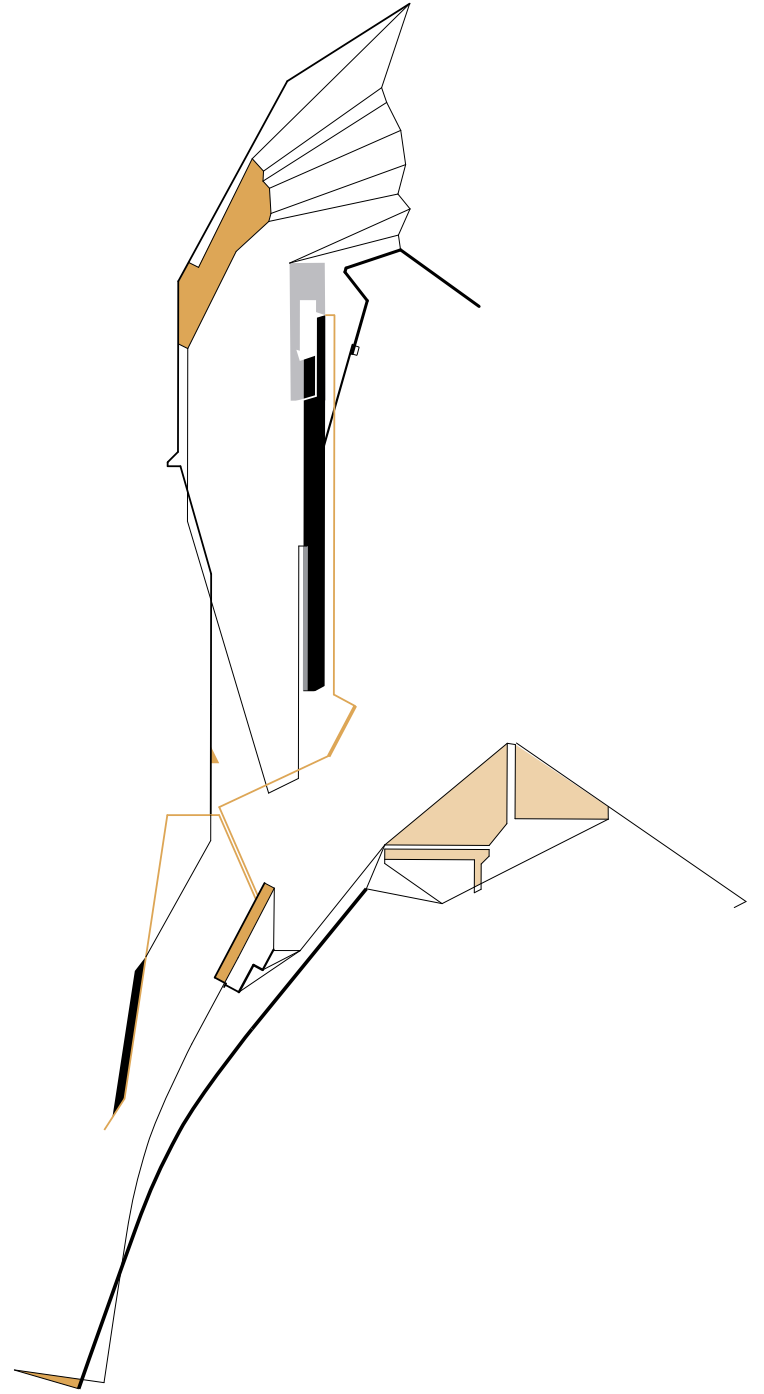

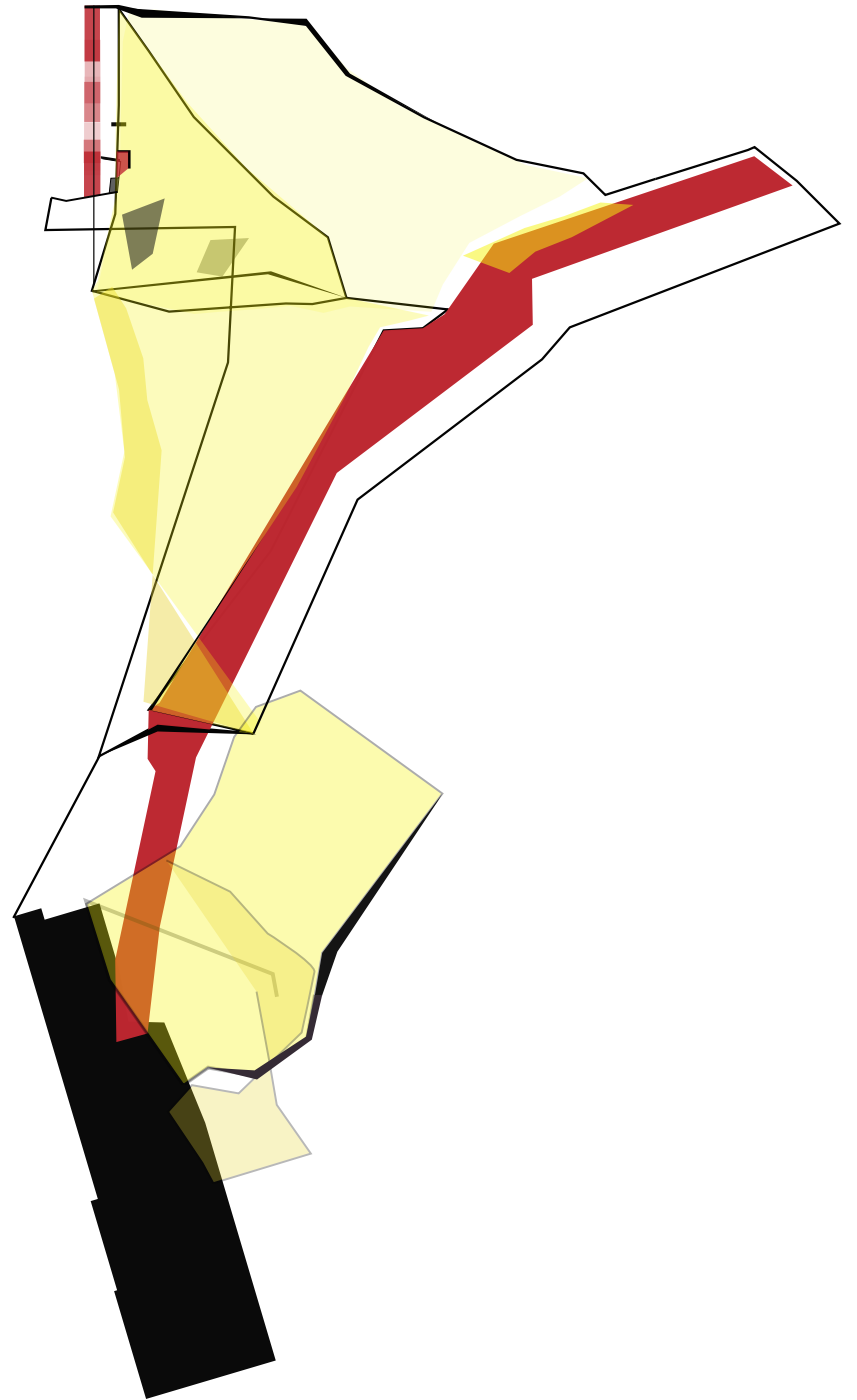

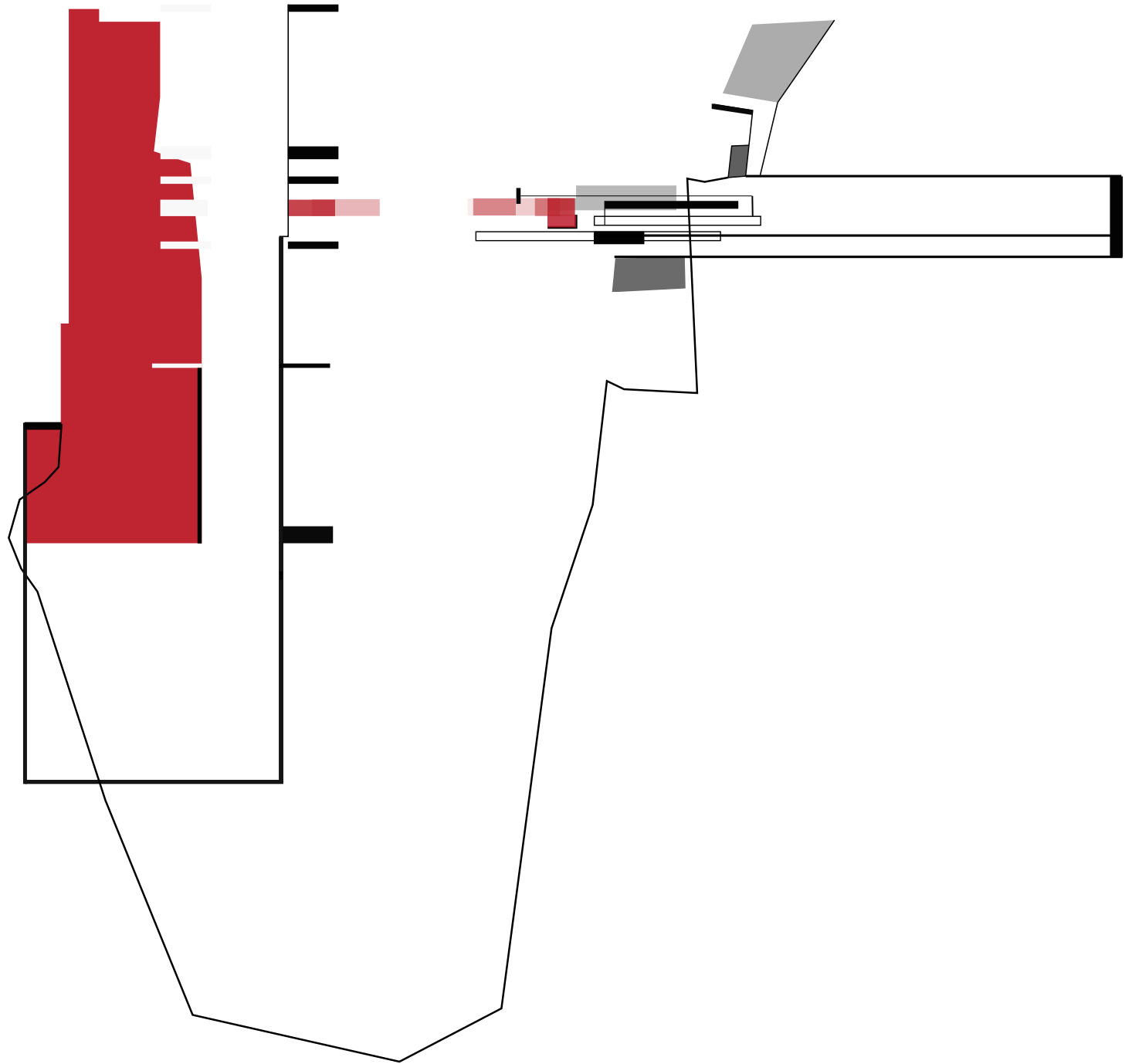

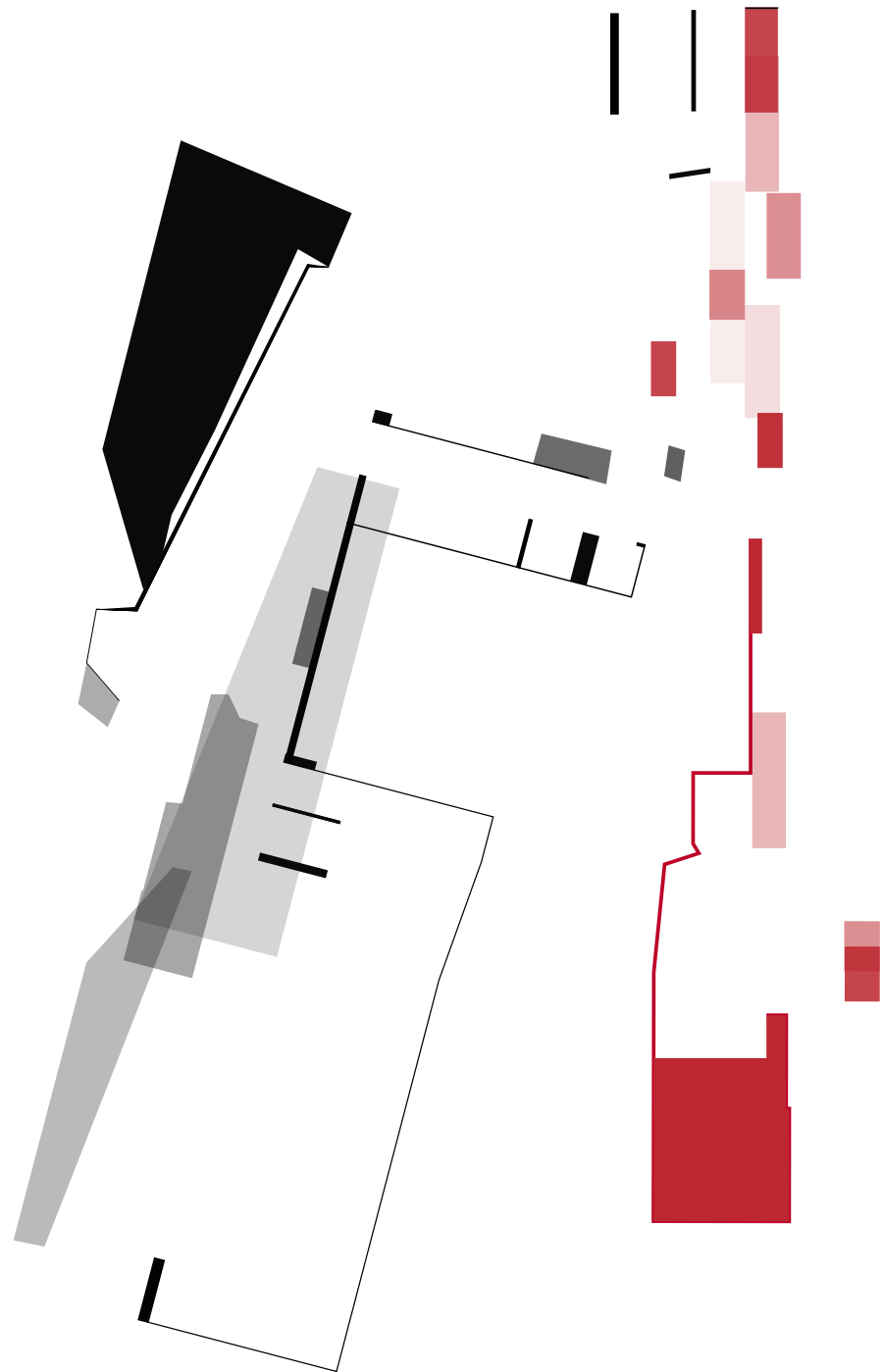

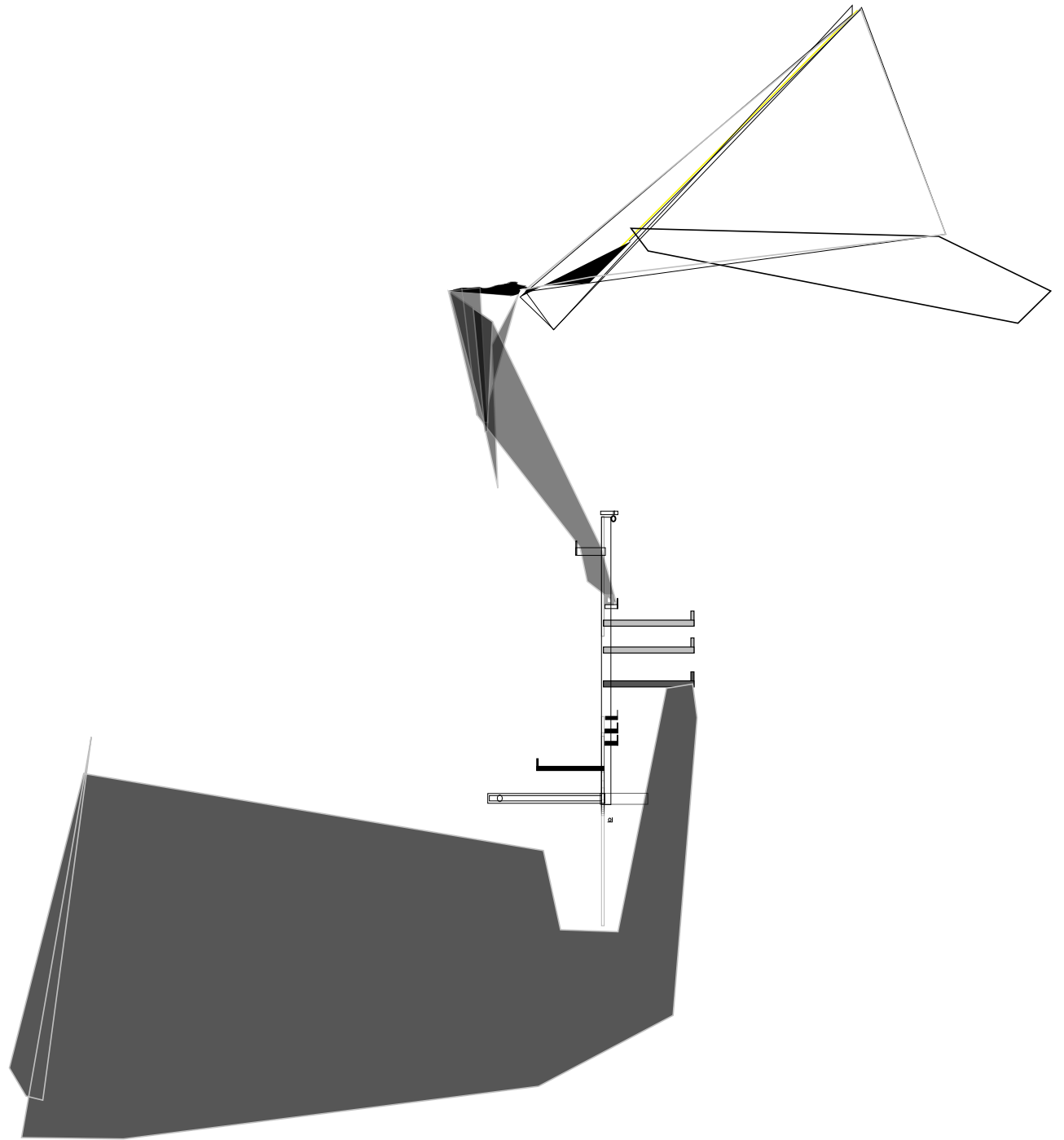

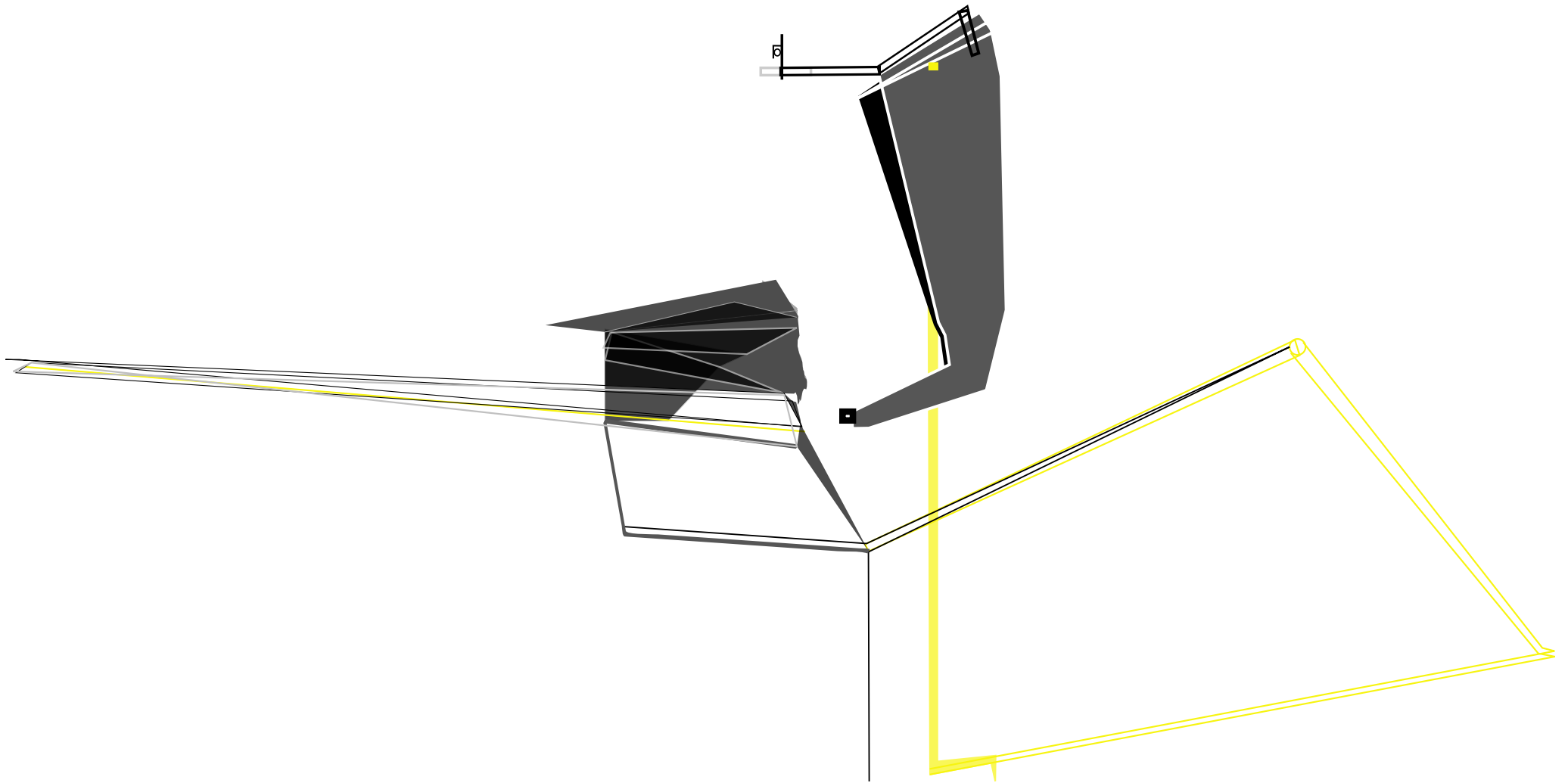

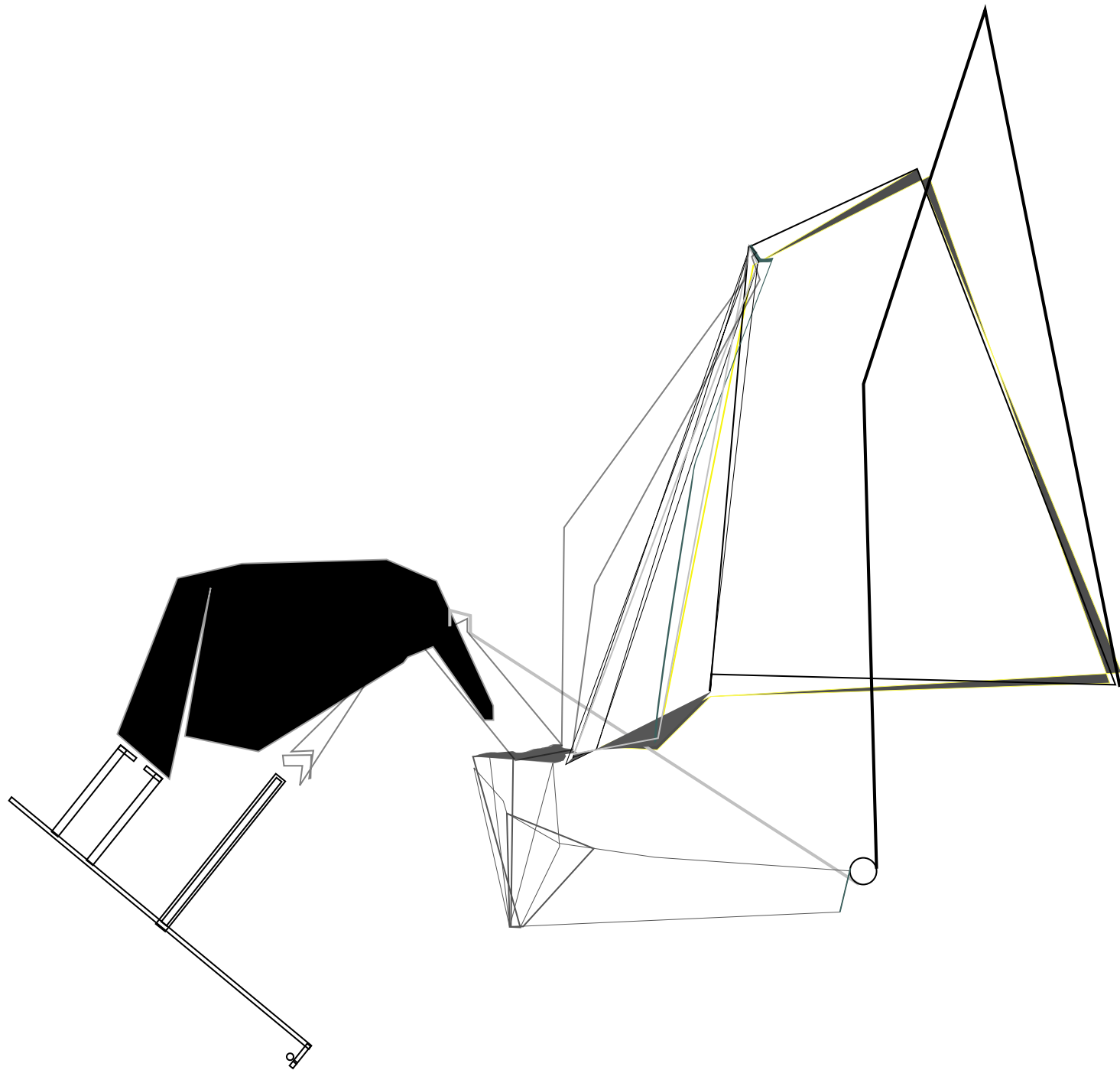

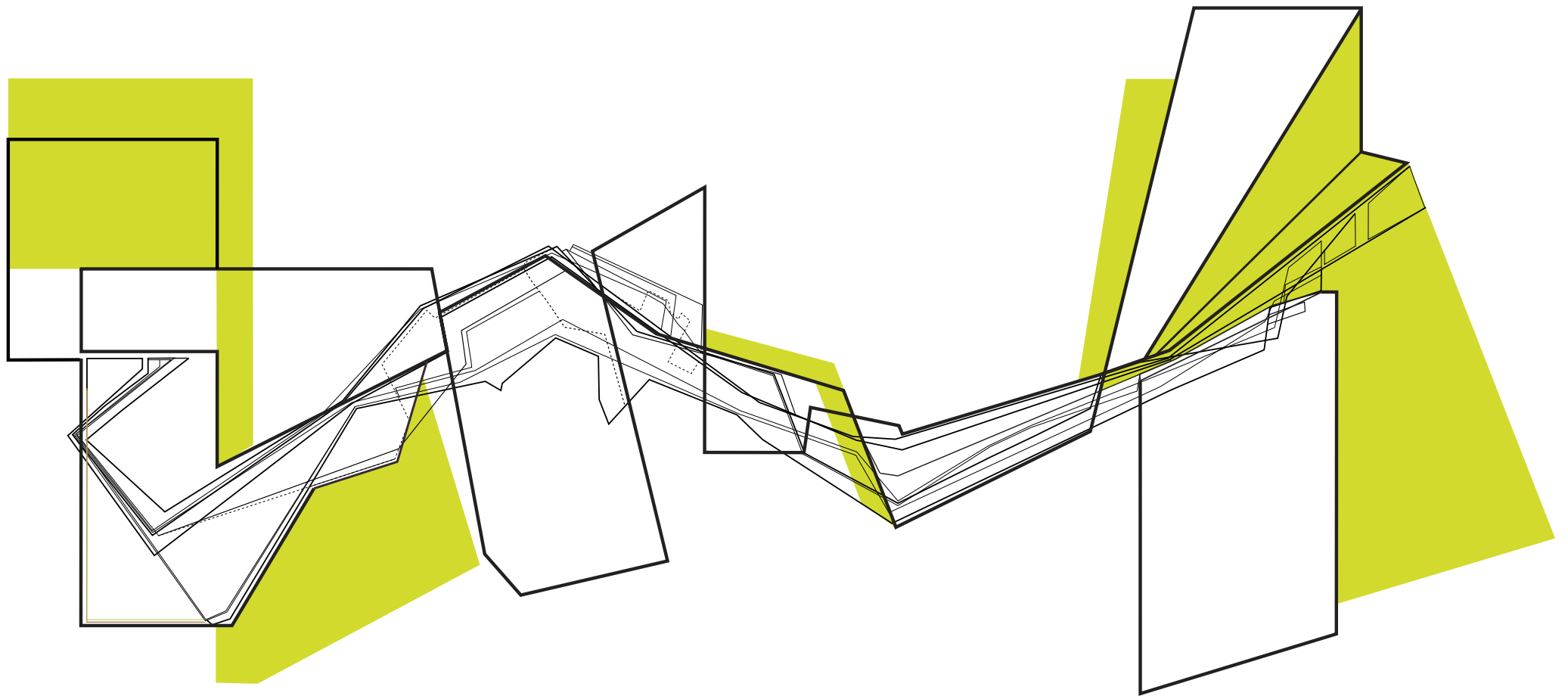

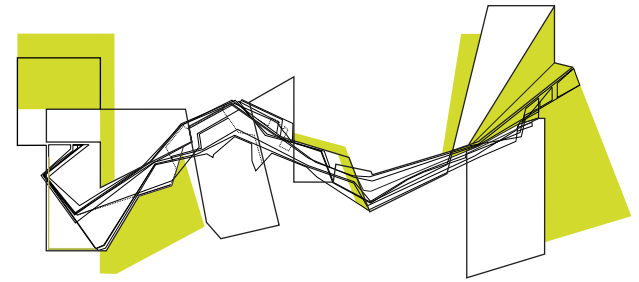

a

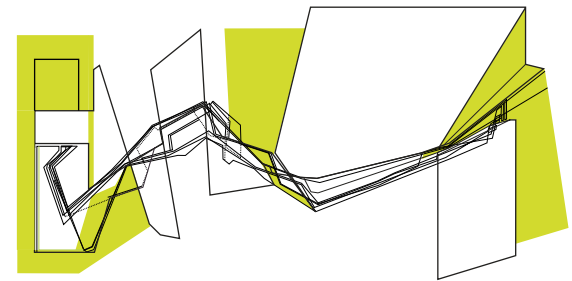

b

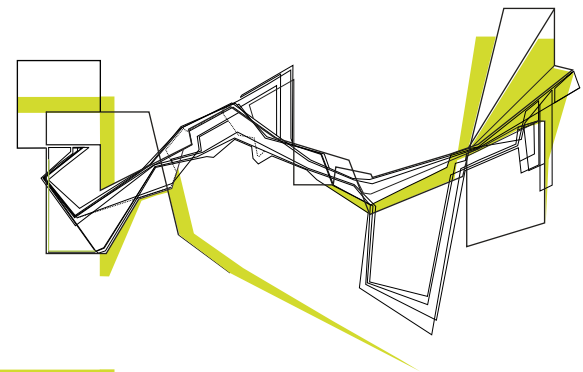

c

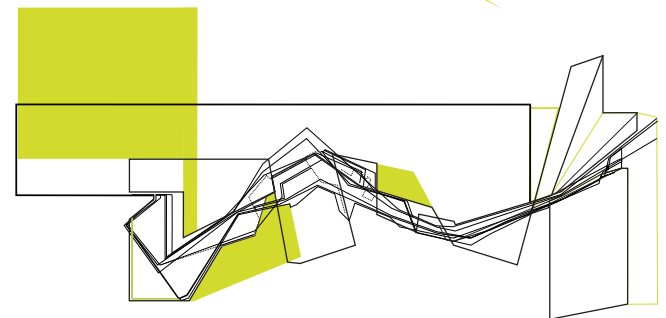

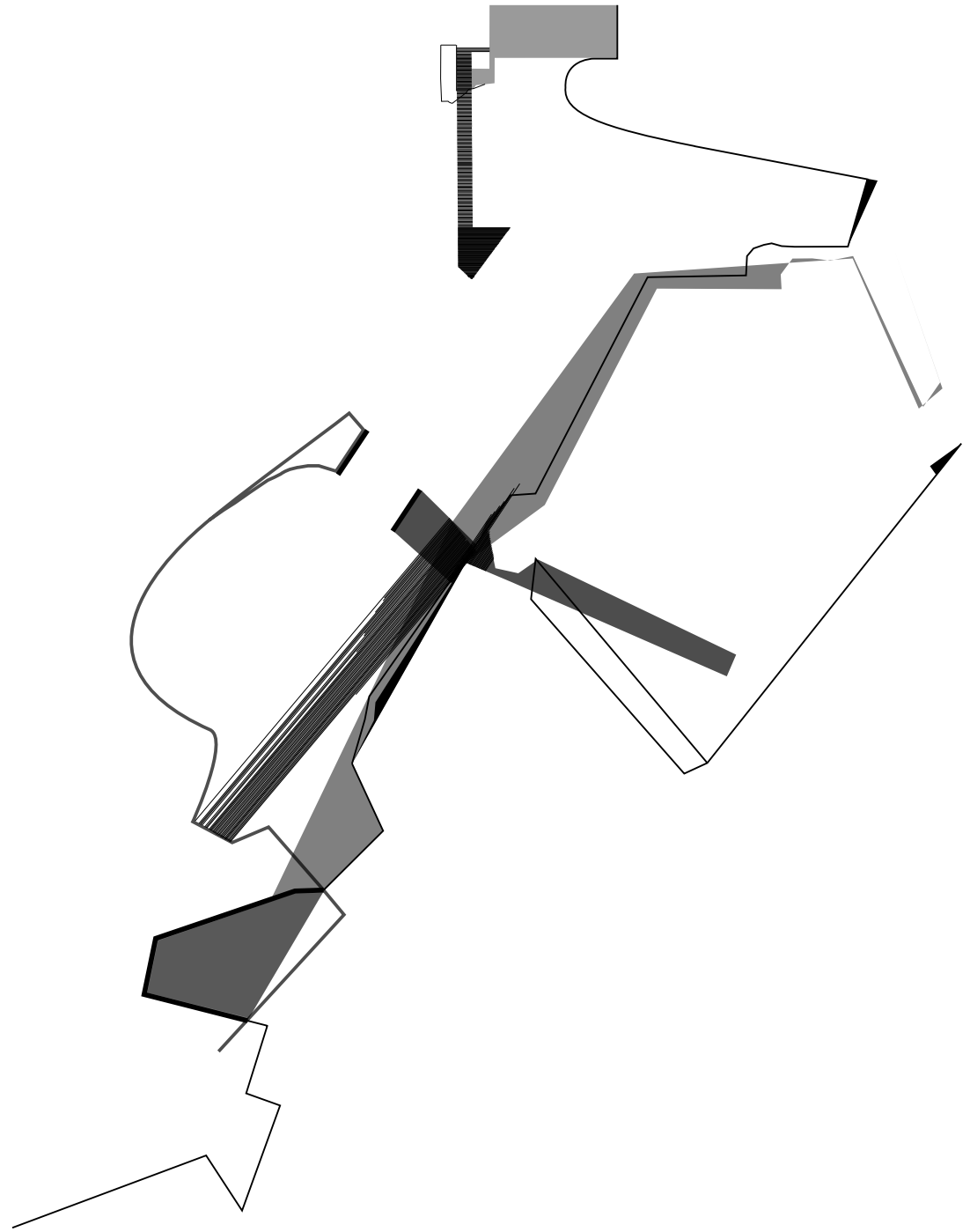

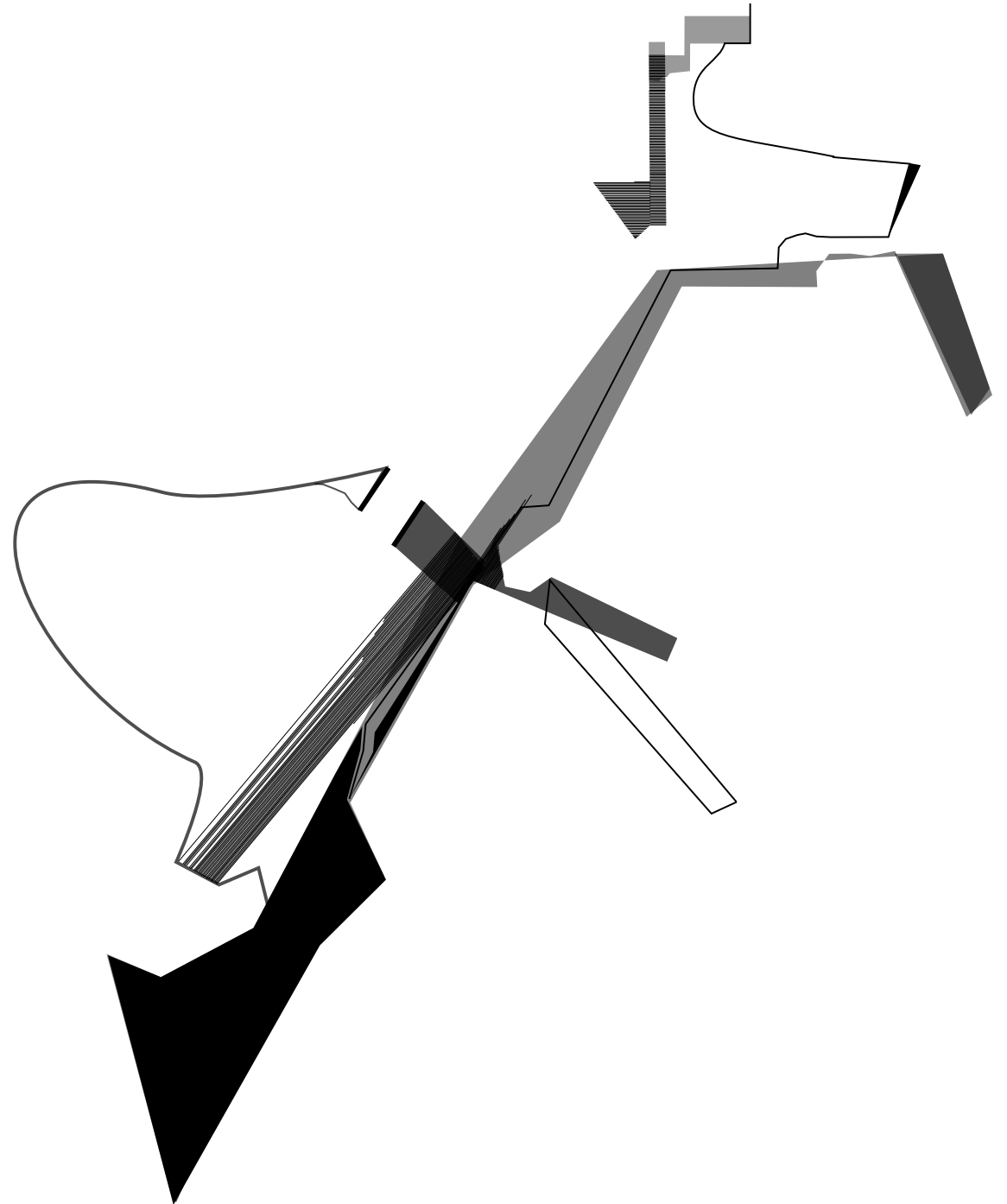

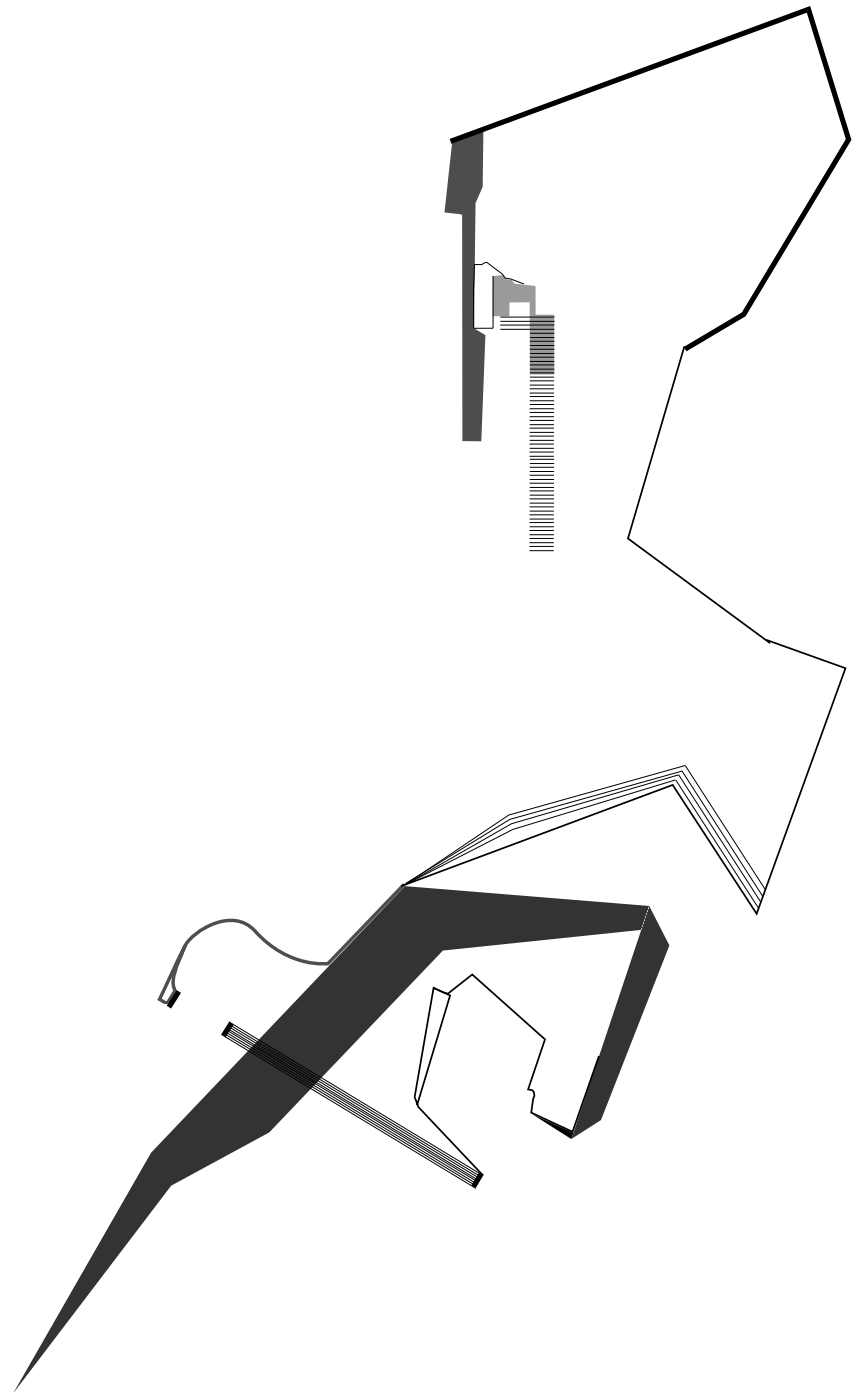

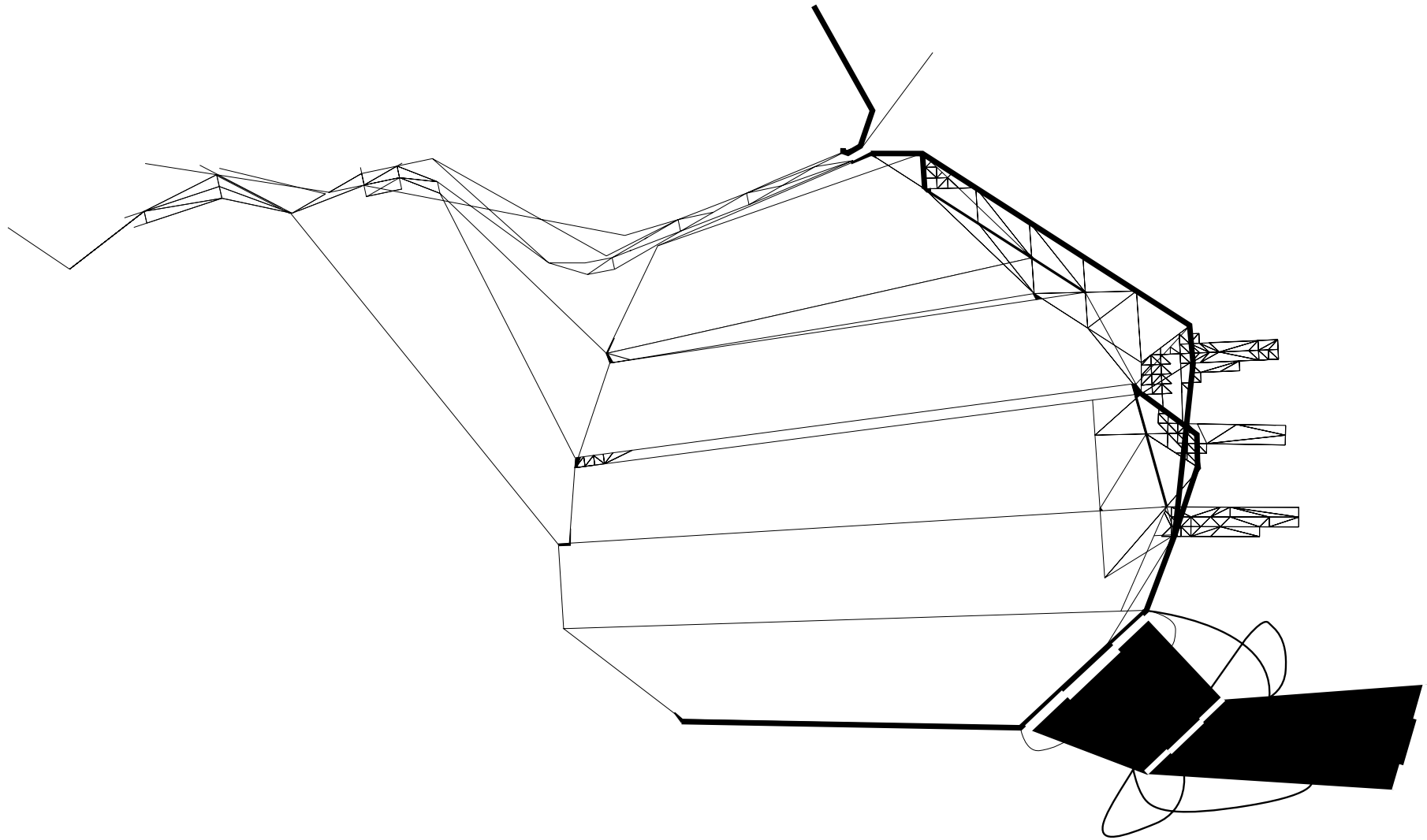



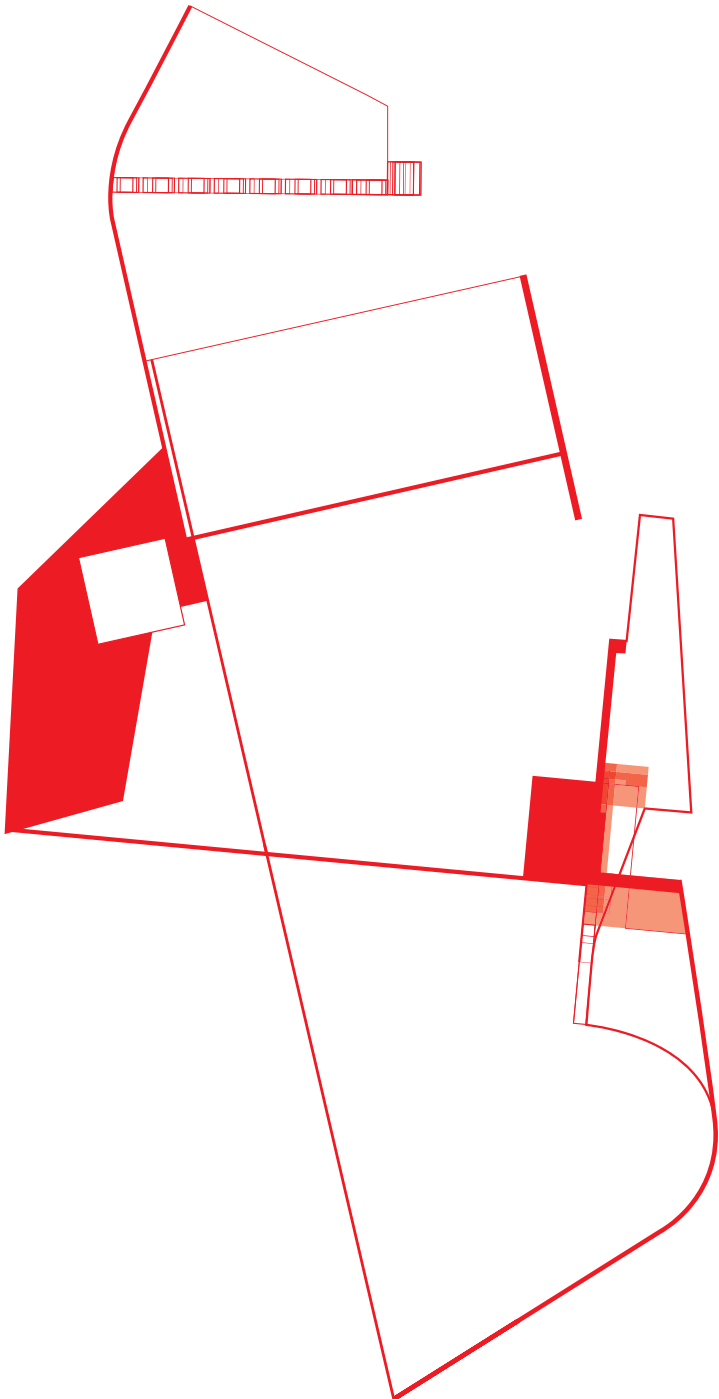

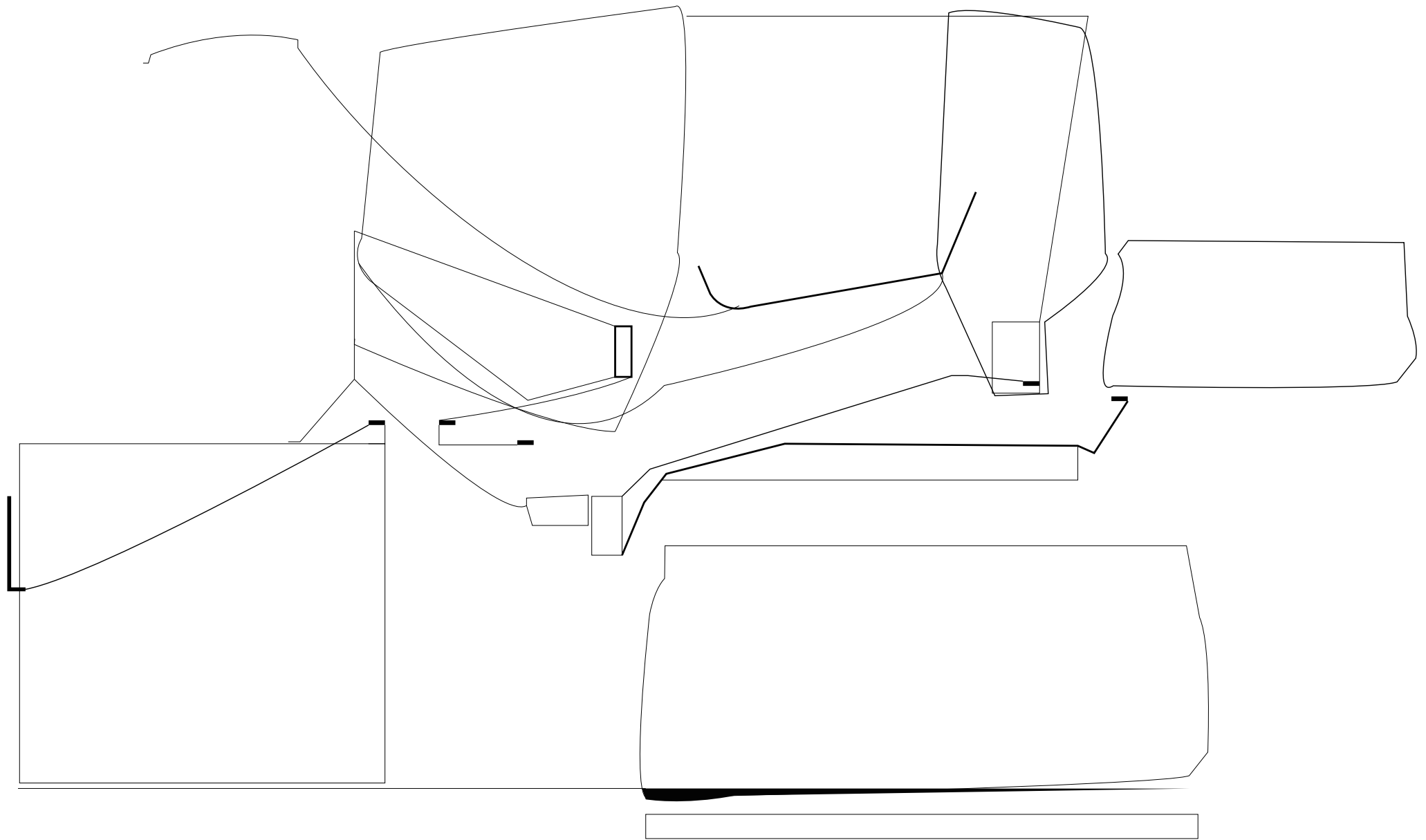

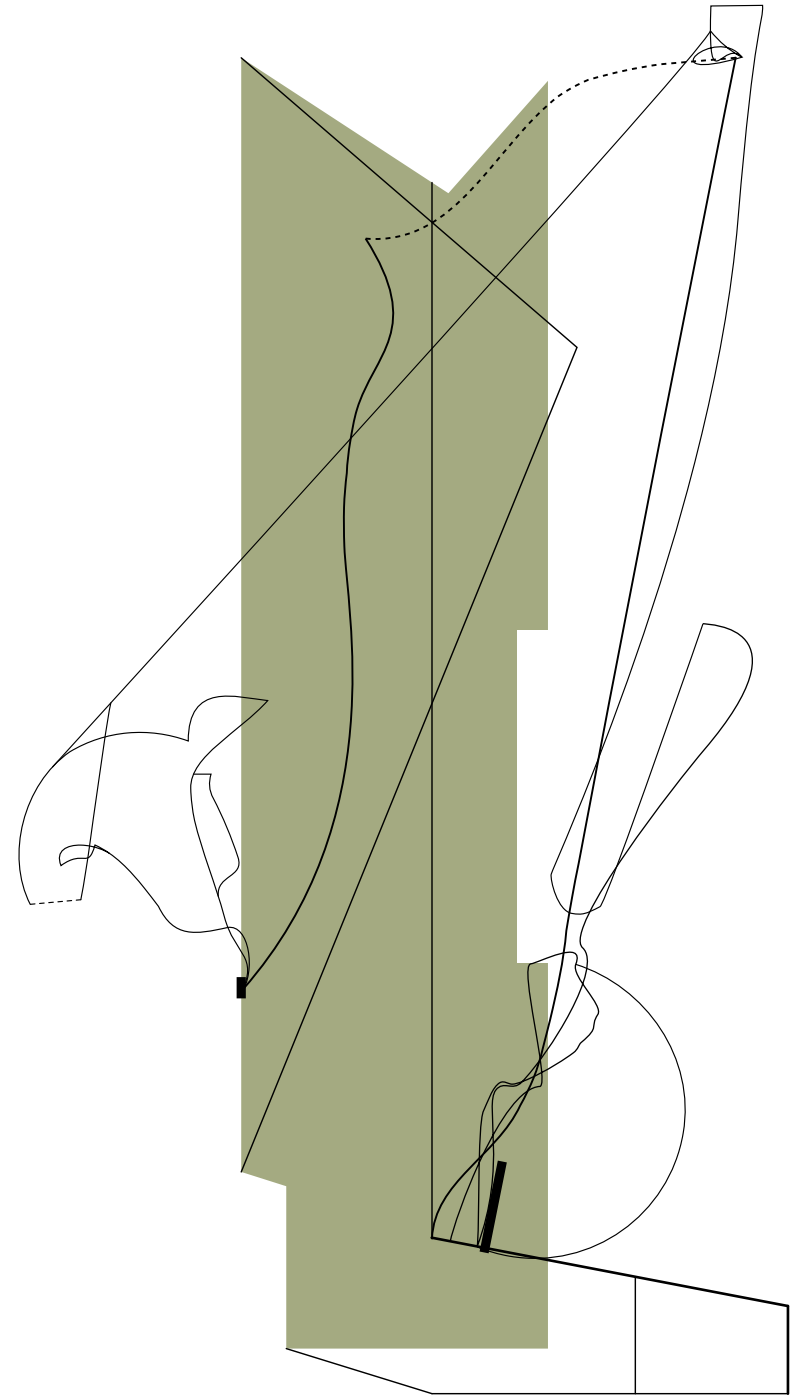

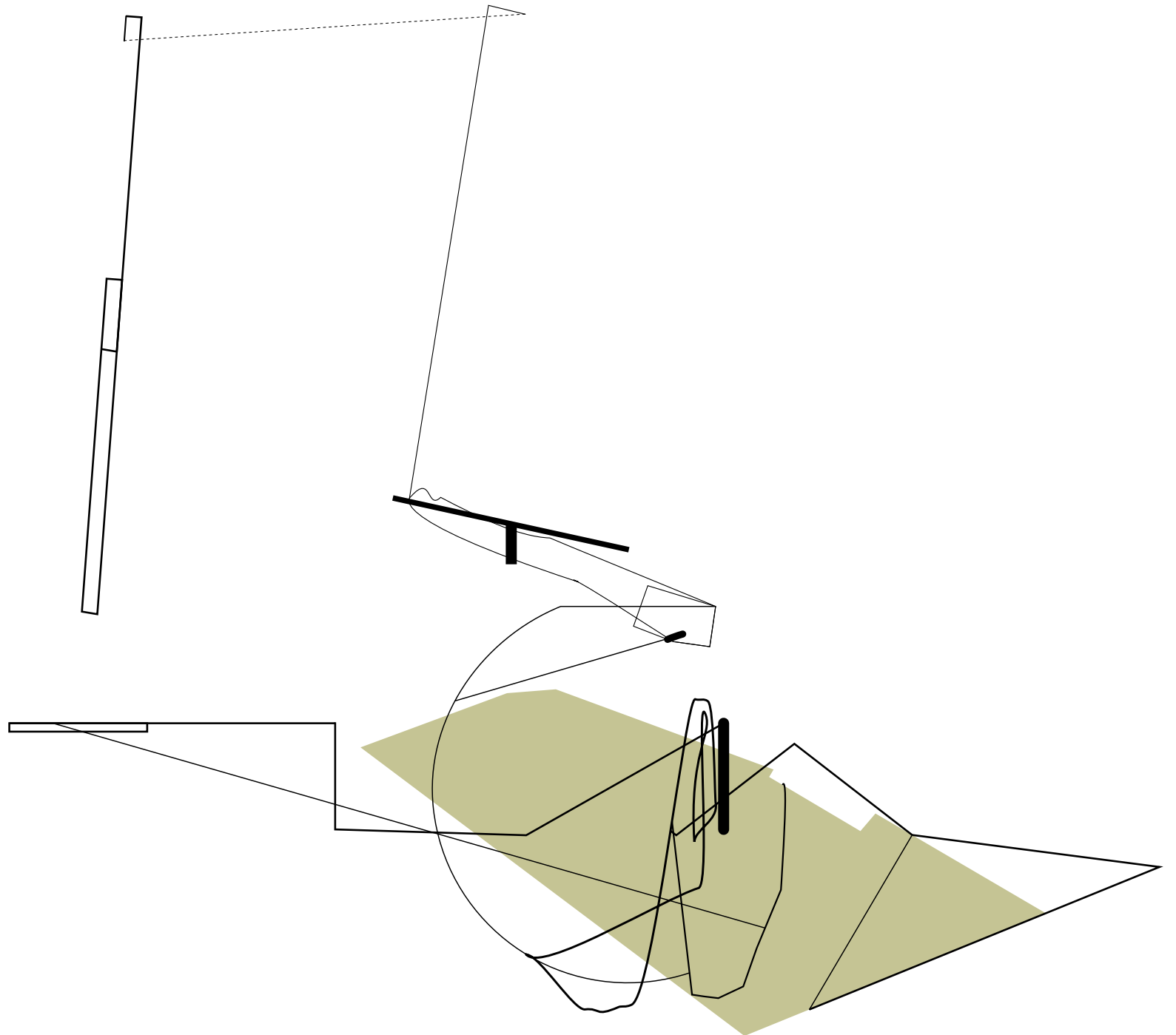

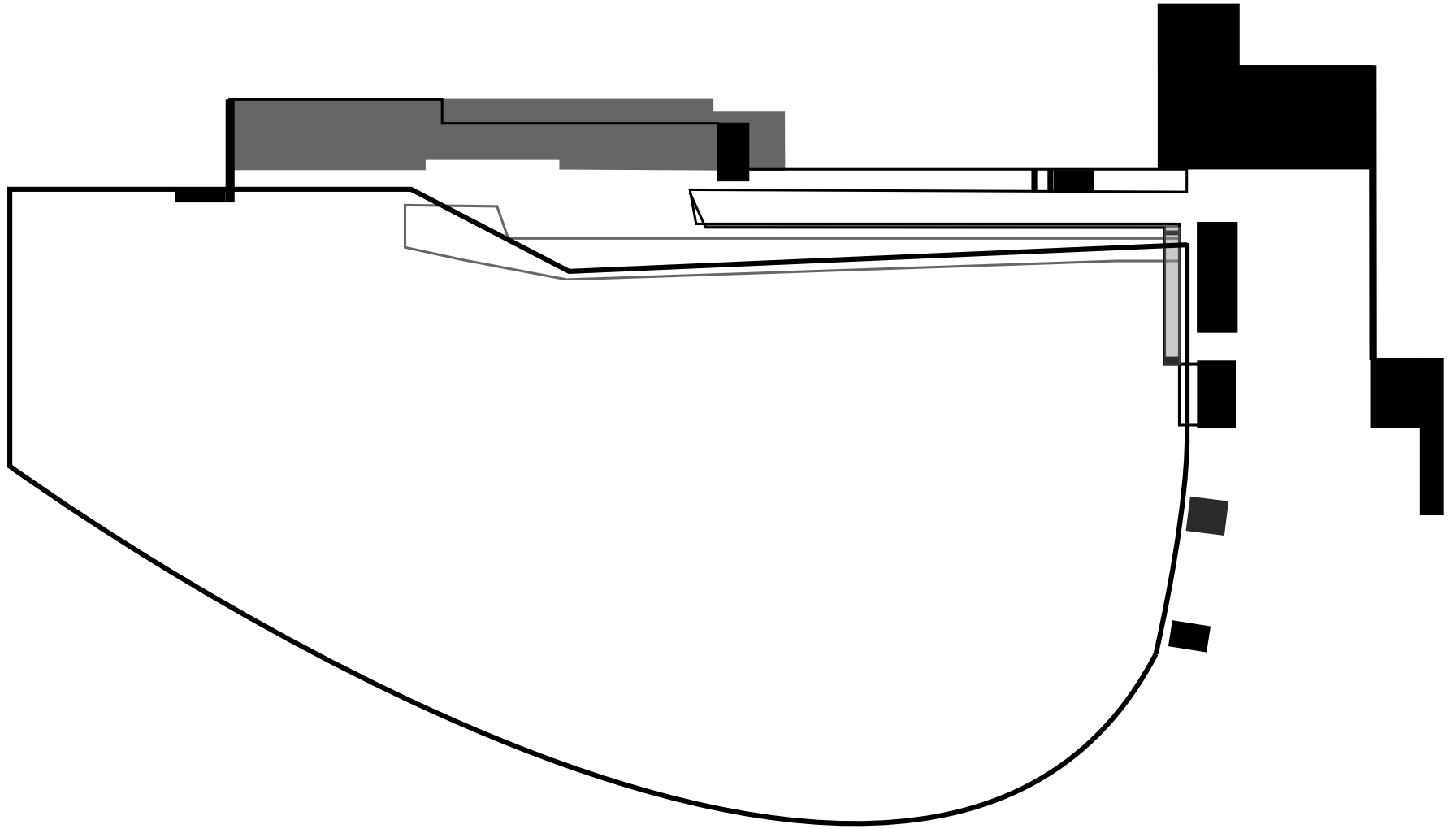

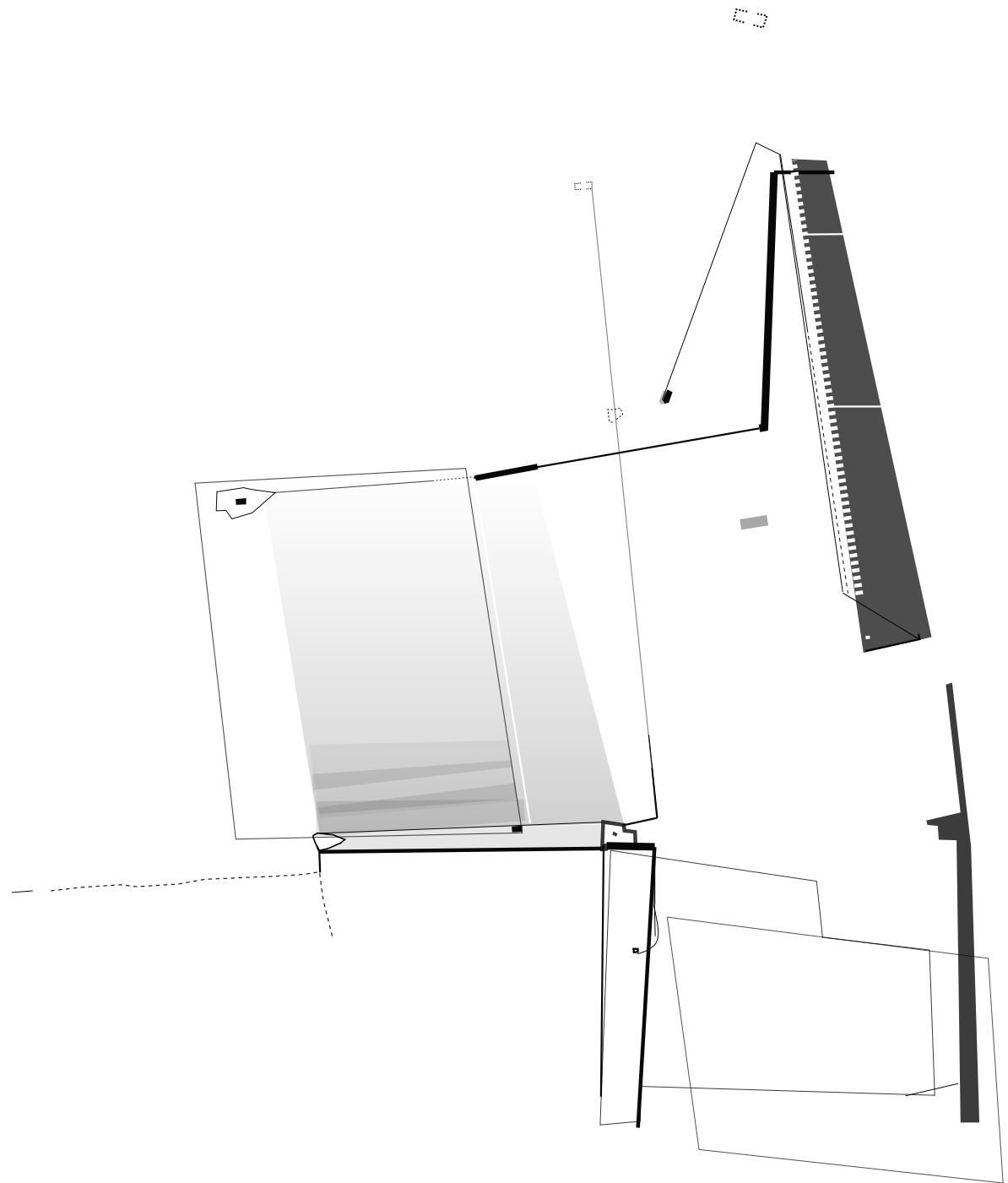

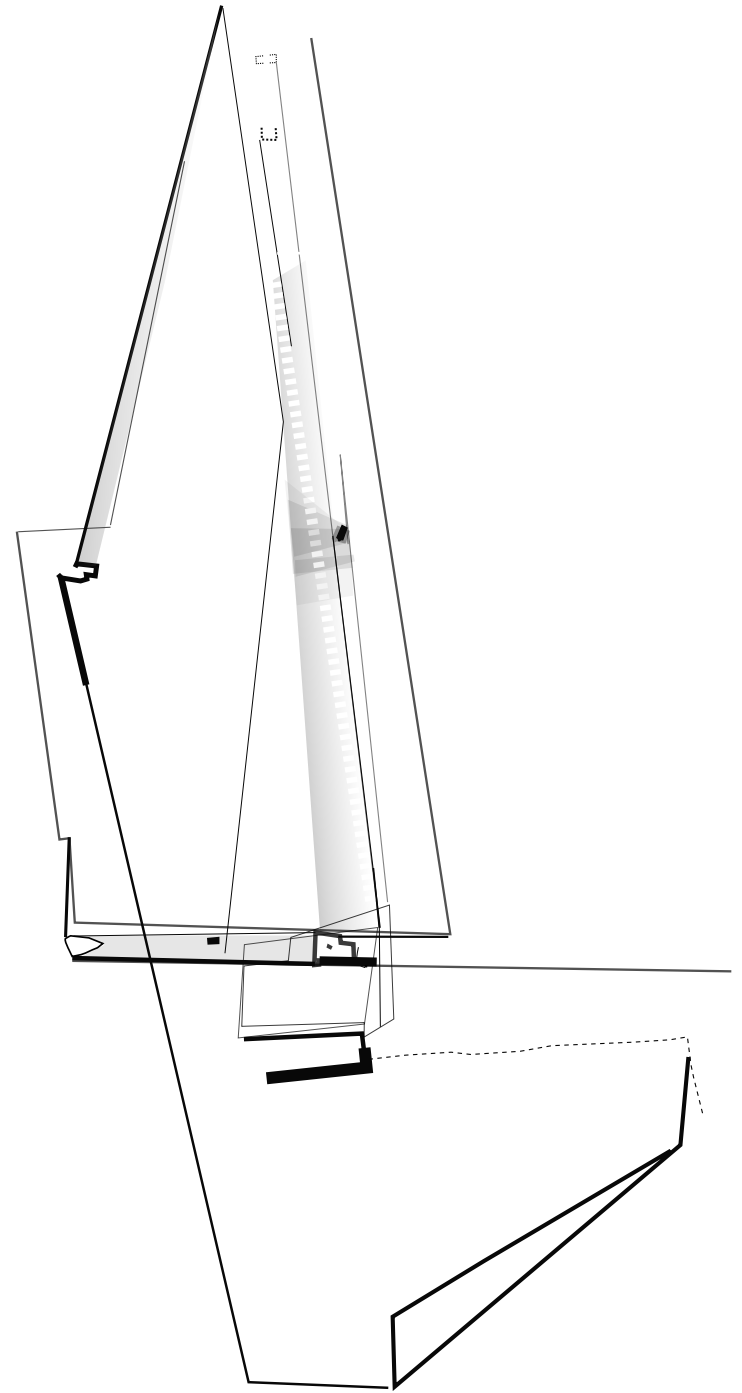

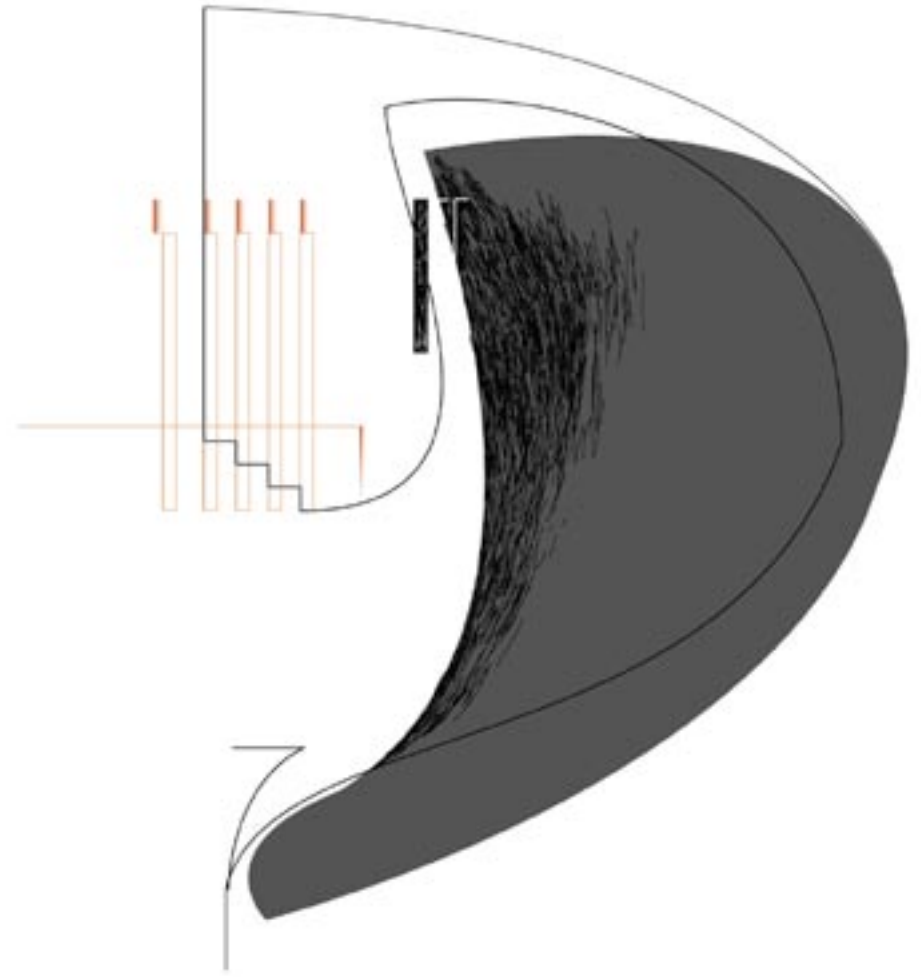

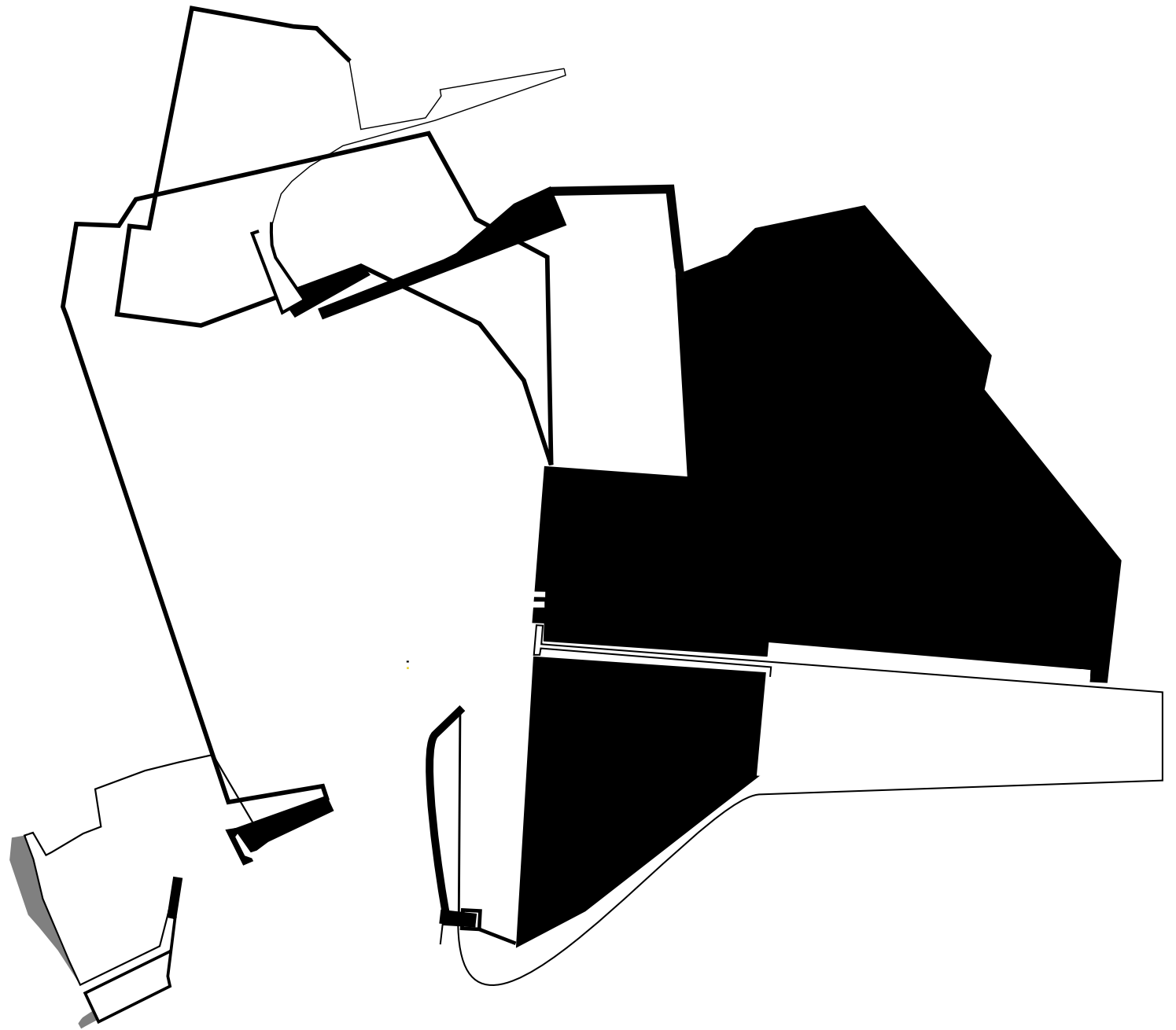

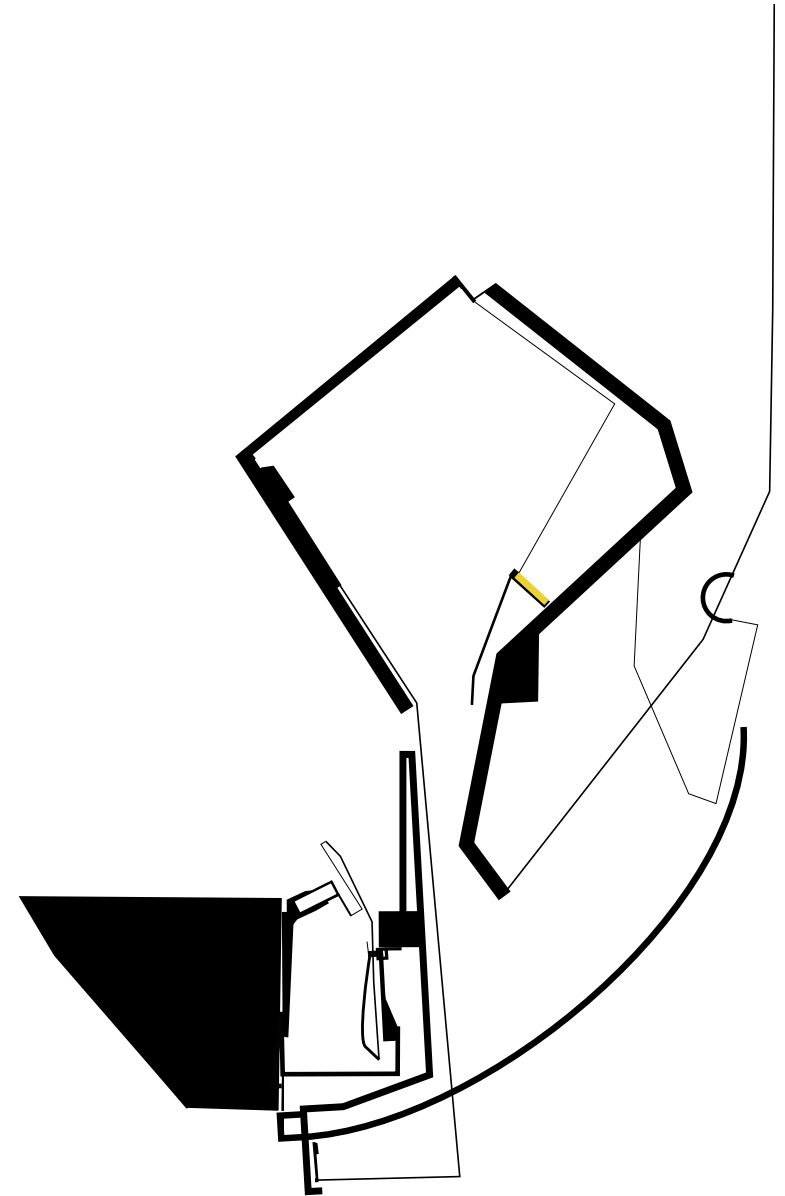
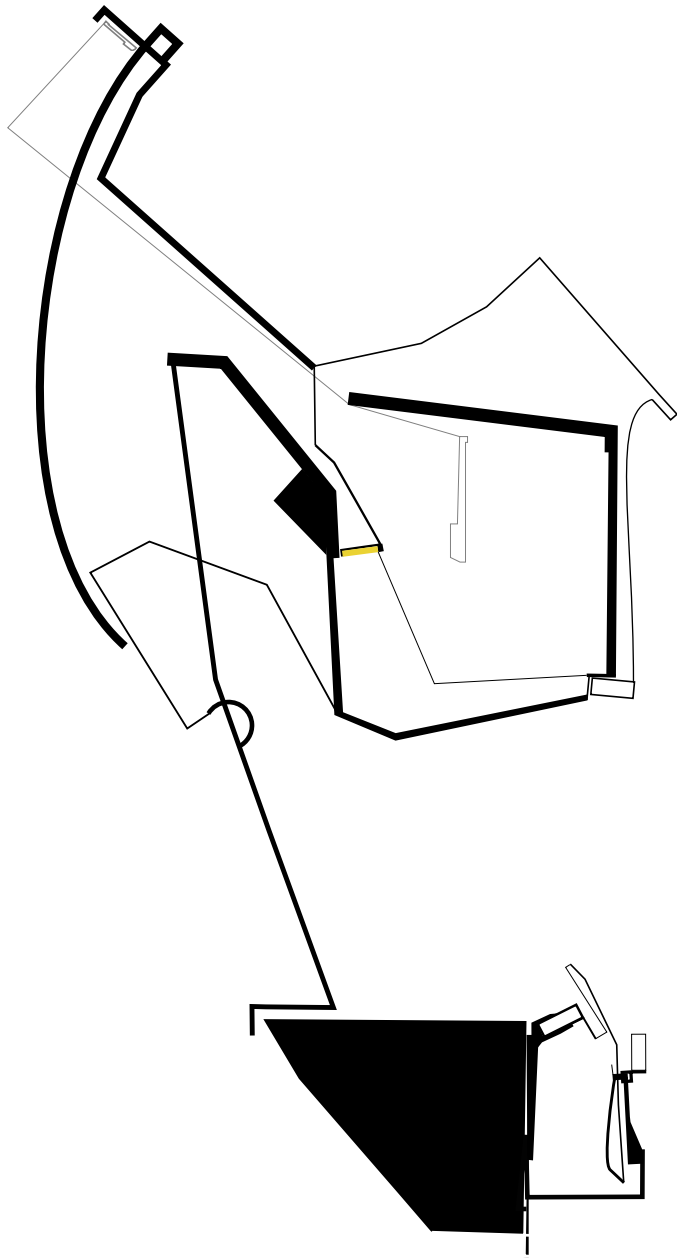

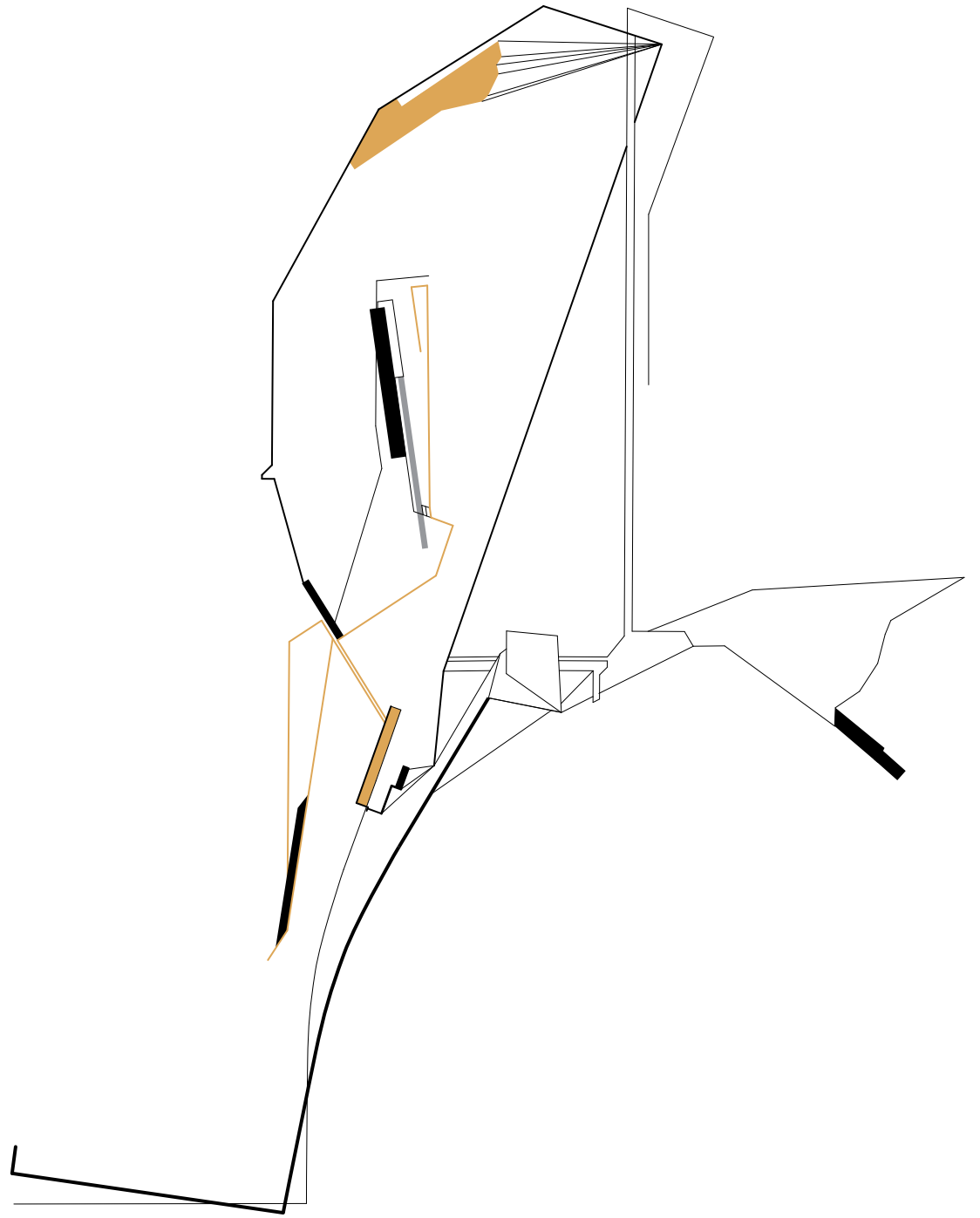

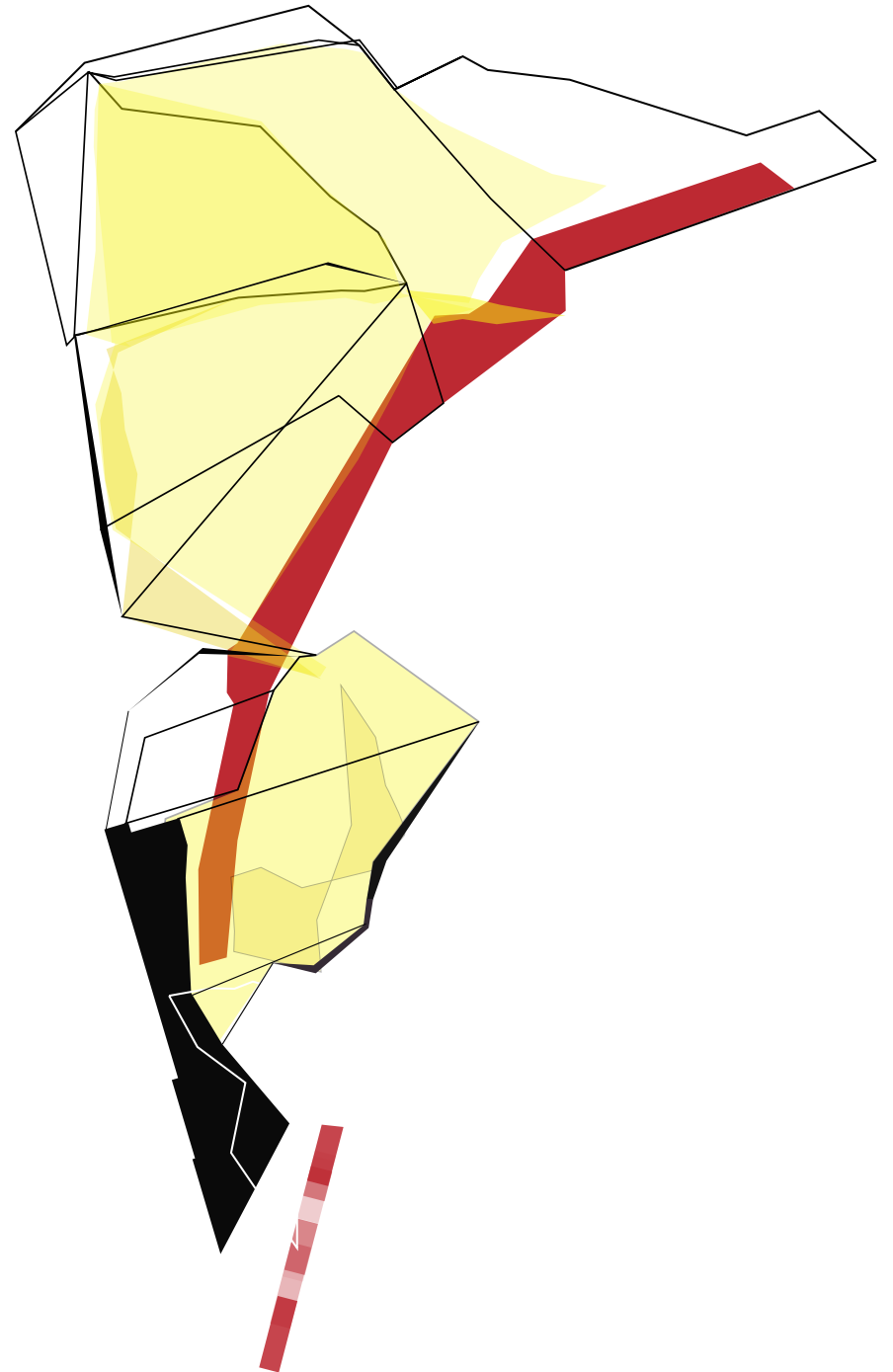

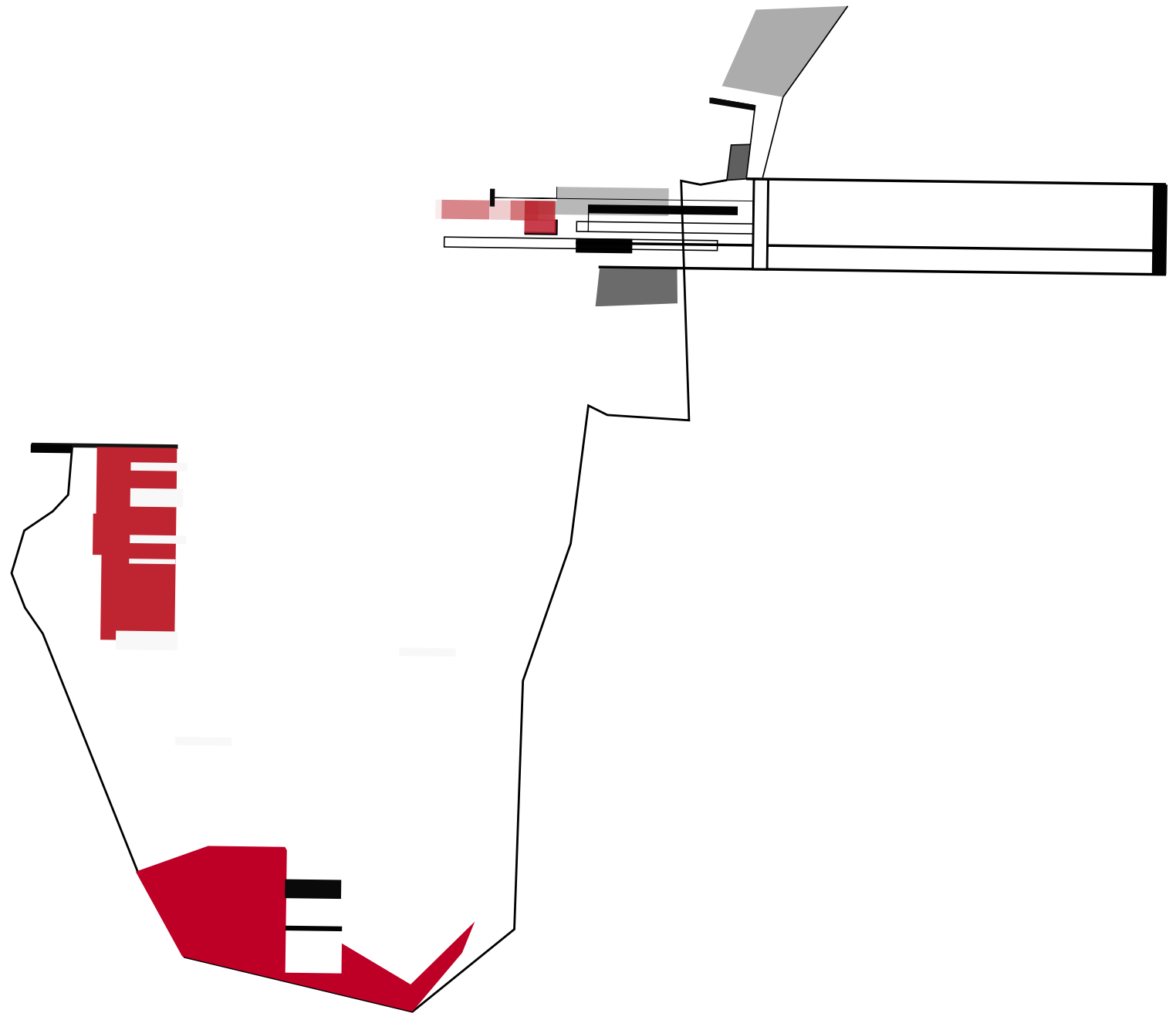

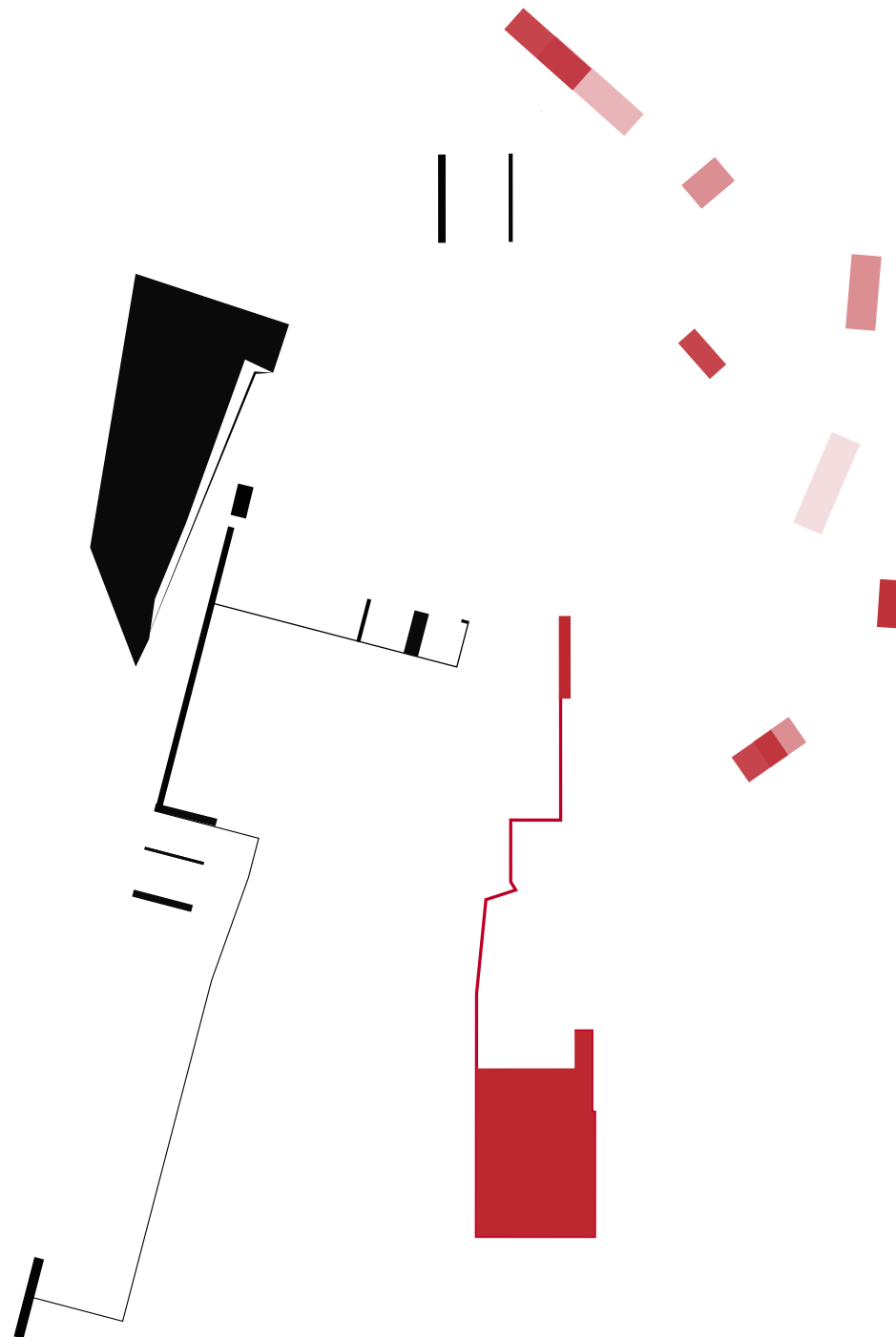

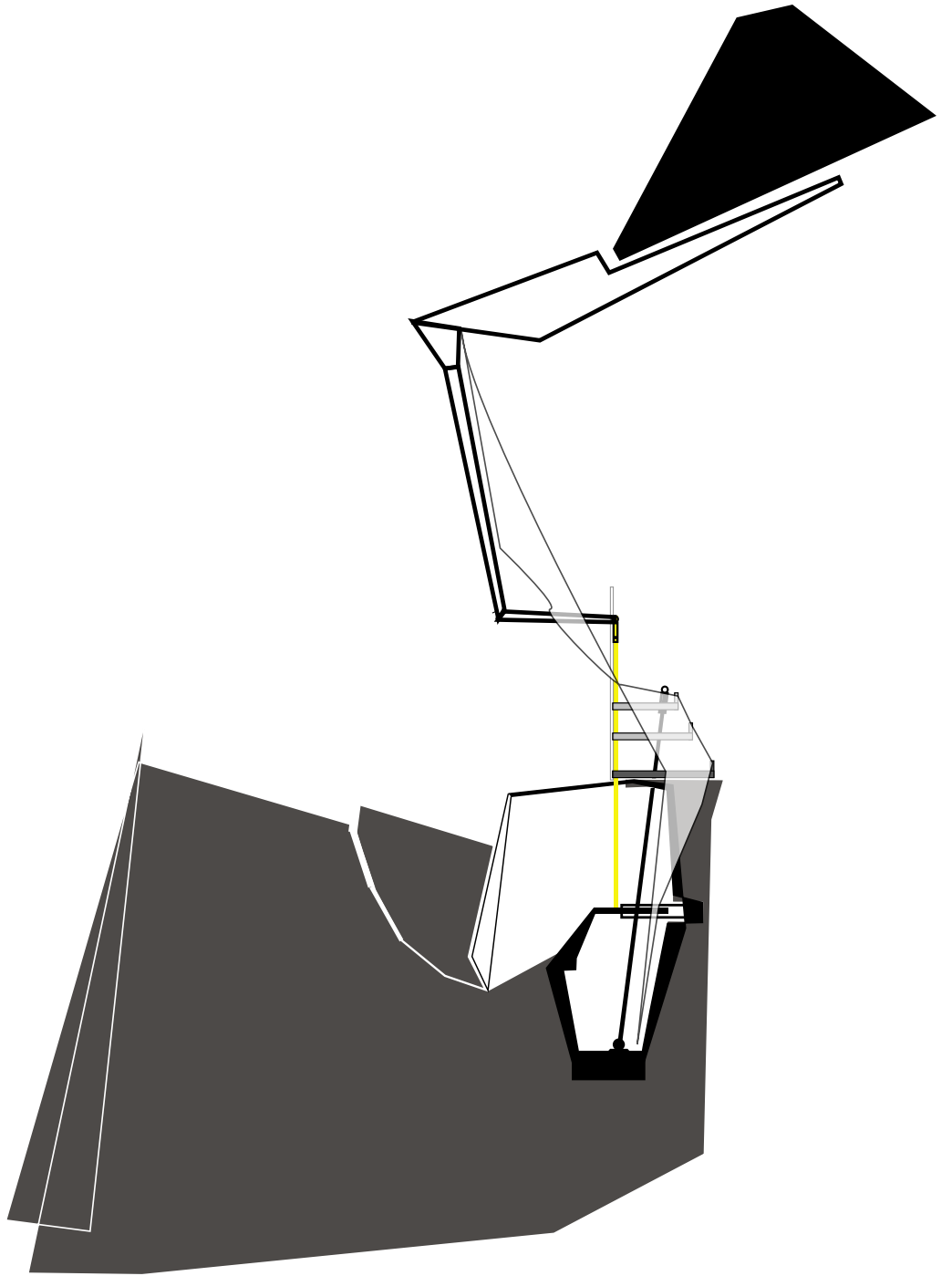

13. marts 2006

- Opstil en "tavle" der sammenstiller egenskaber på tværs af gruppens tegninger. Udpeg afgrænsede karakteristiske konfigurationer i tegningerne og skab en kategorisering på tværs af materialet der grupperer sammenlignelige egenskaber og karakteristika. Udvælg kategorierne på en måde så de undgår en simpel forskelstækning hvor egenskaberne opstilles som binære modsætninger. Skab i stedet kategorier der både skiller og samler, både rækker ud og foldes ind, etc.

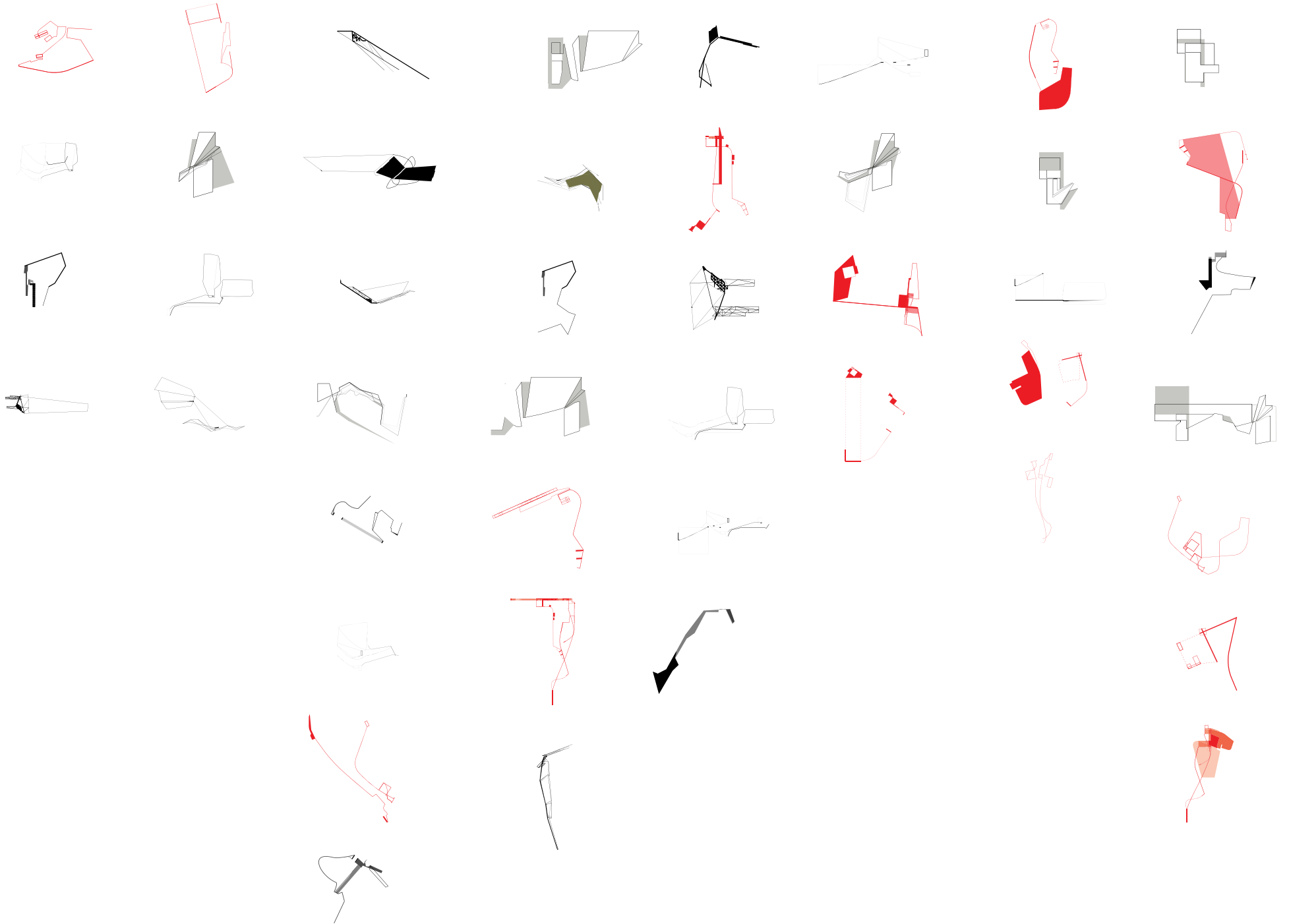

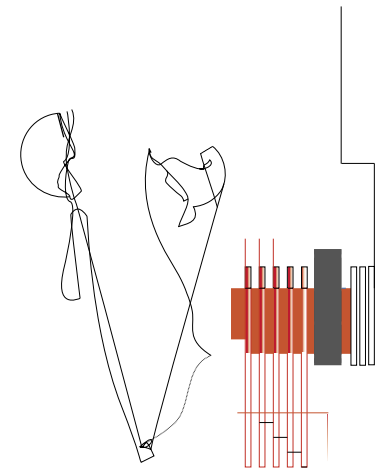
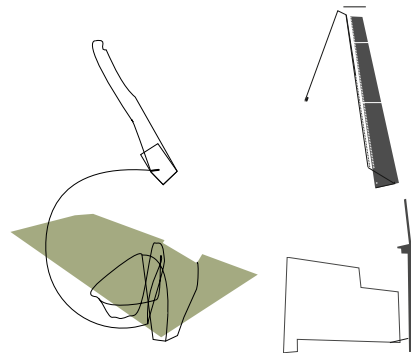
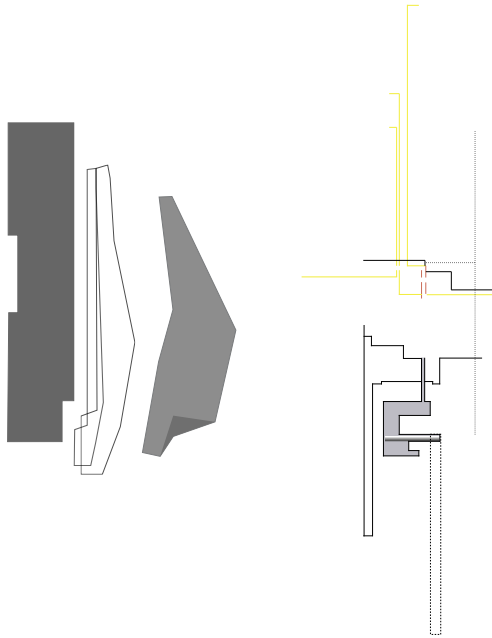
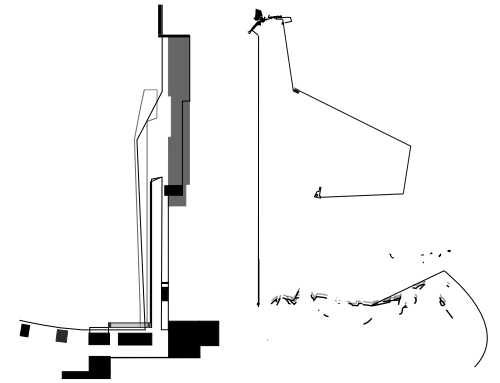
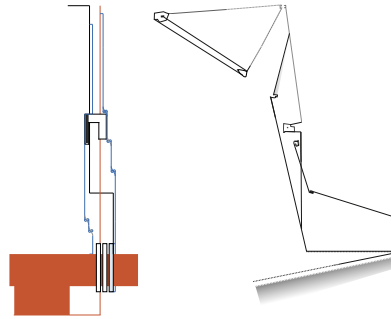
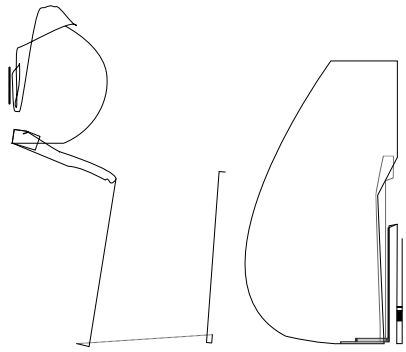

kobling/frisætning

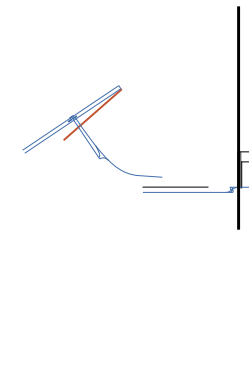
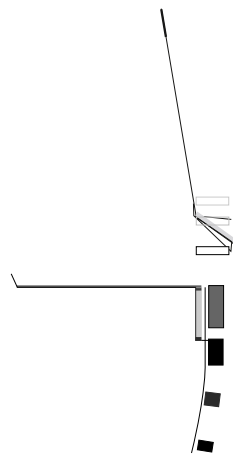
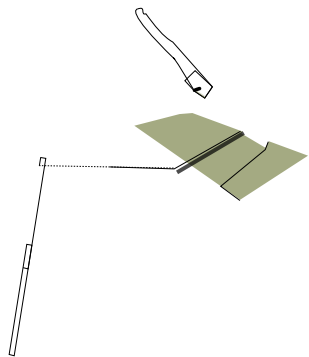

udspænding/sammentrækning

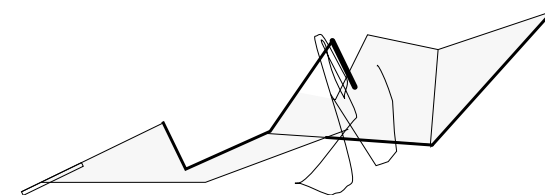
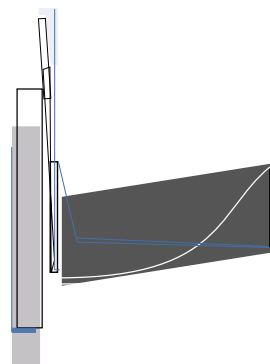
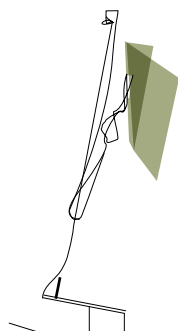

glidning/forsætning

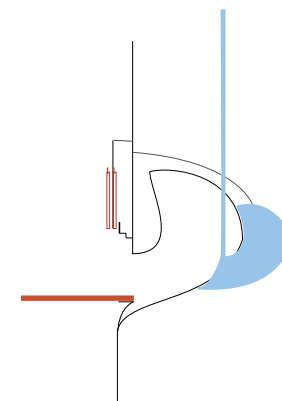
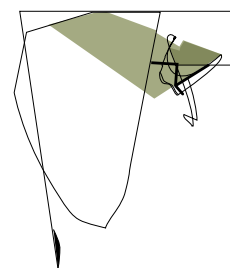
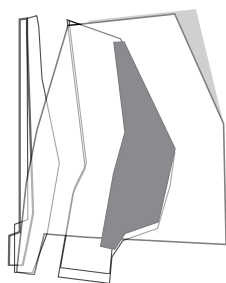

indeksikal/relativ

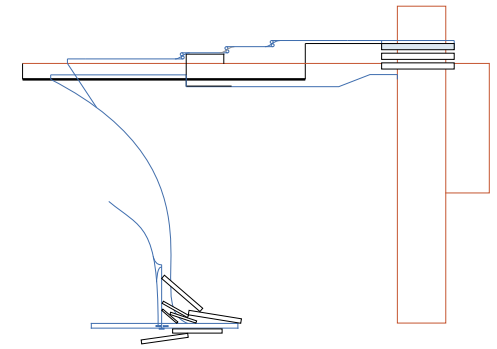
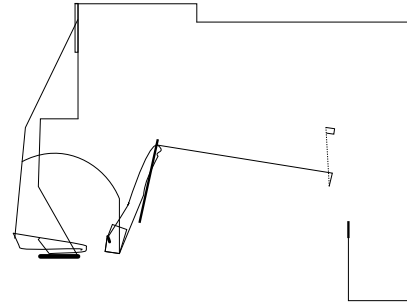
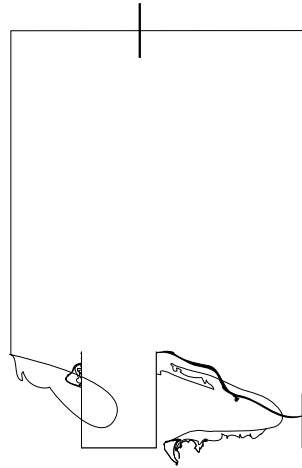

indskrevet/udfoldet

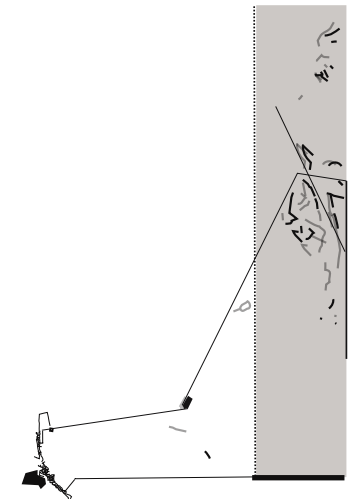
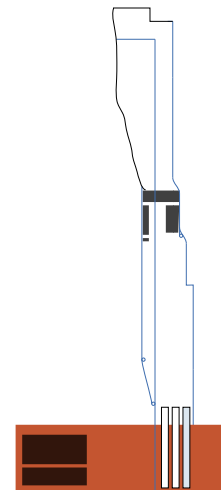
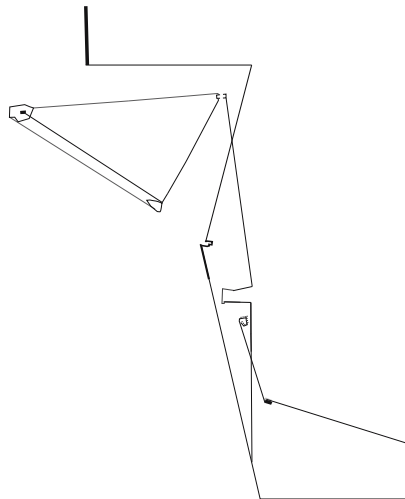

styrt/futteral

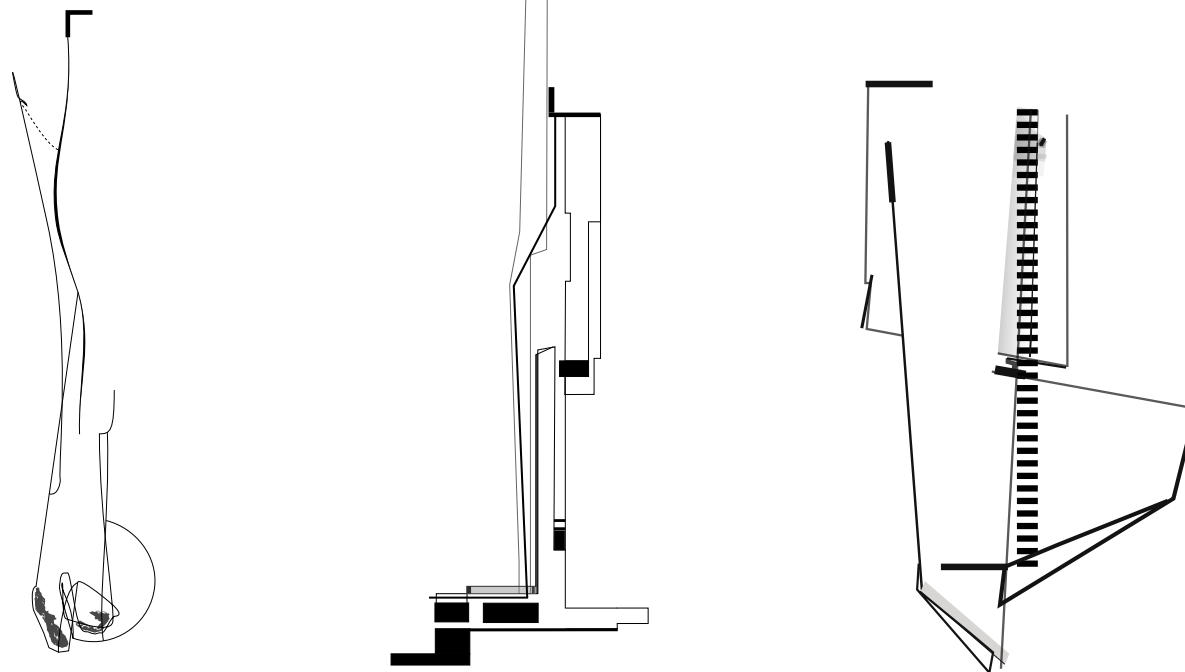

flankeret/stribet

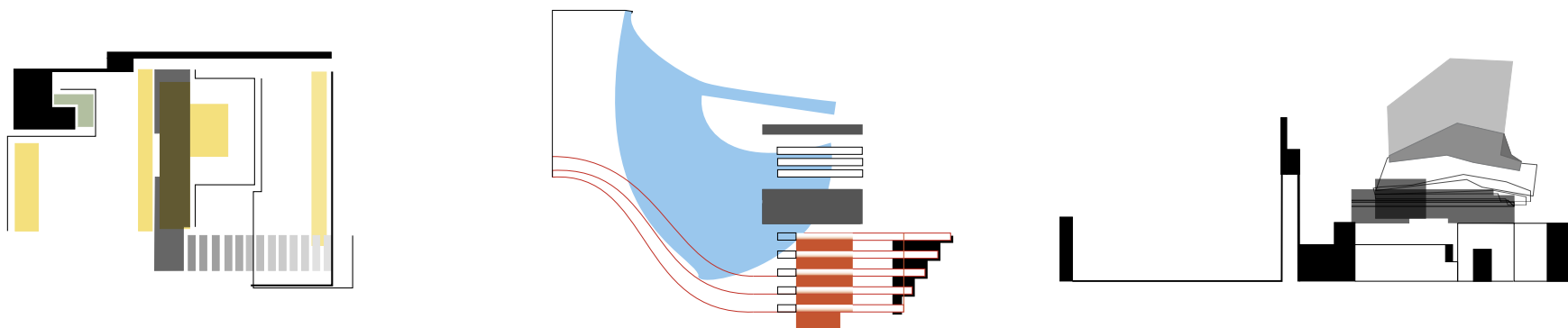

UDMÅLER

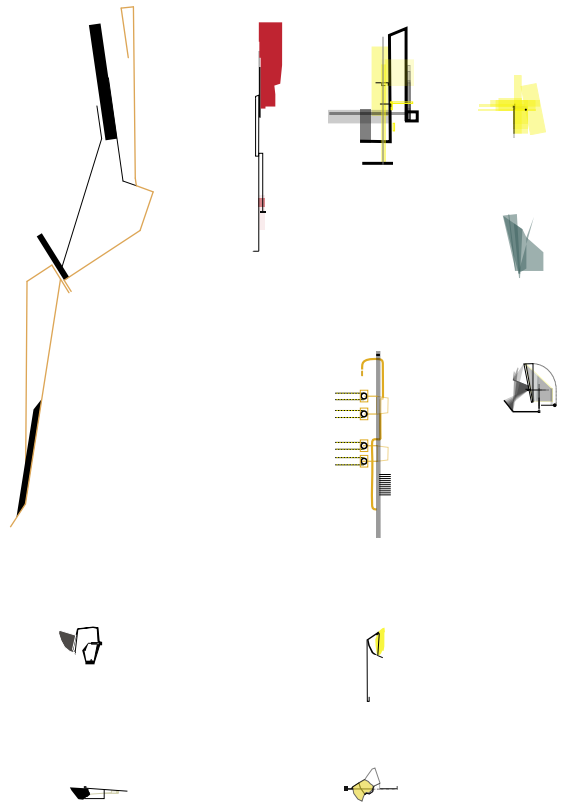

VÆGT

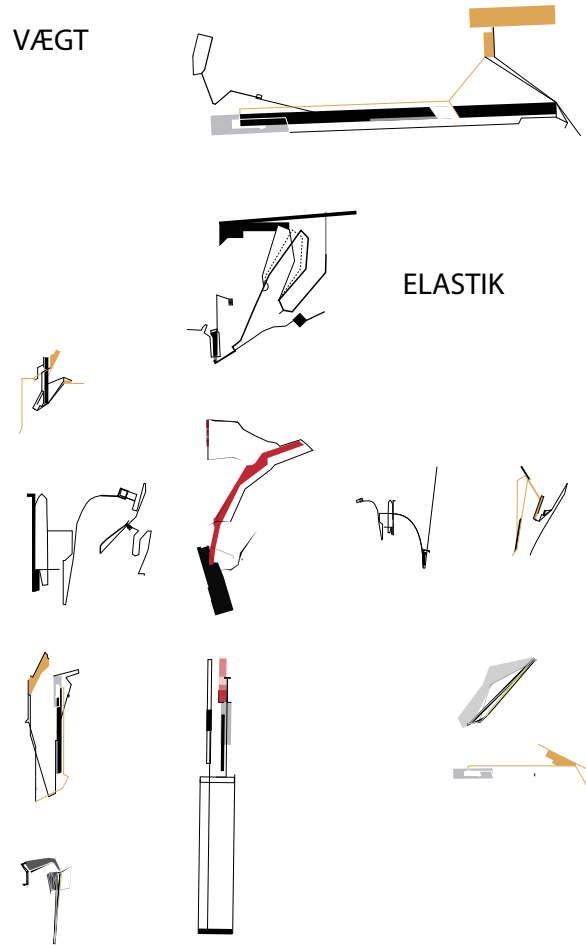

UDSVING

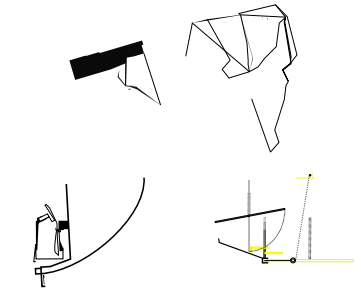

ELASTIK

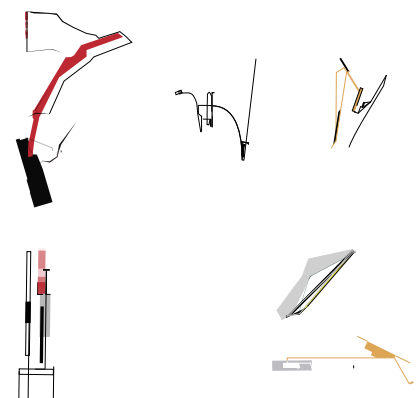

KROP

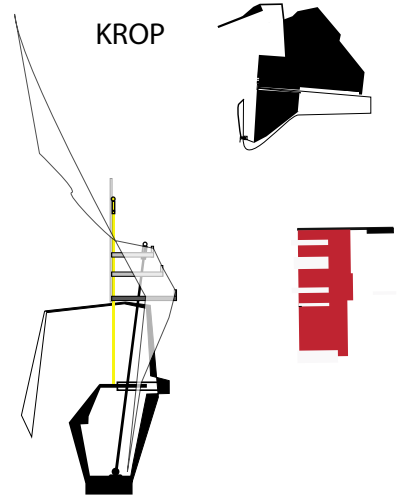

PENDUL

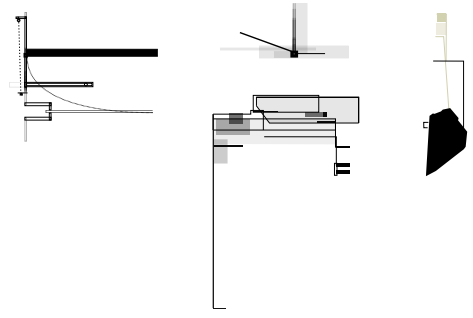

STEMPEL

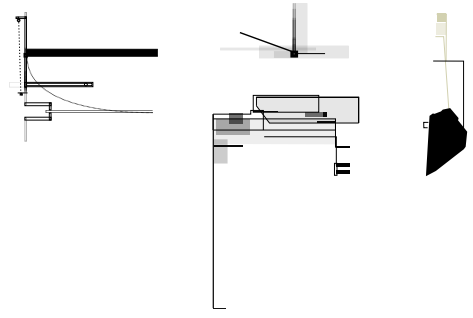

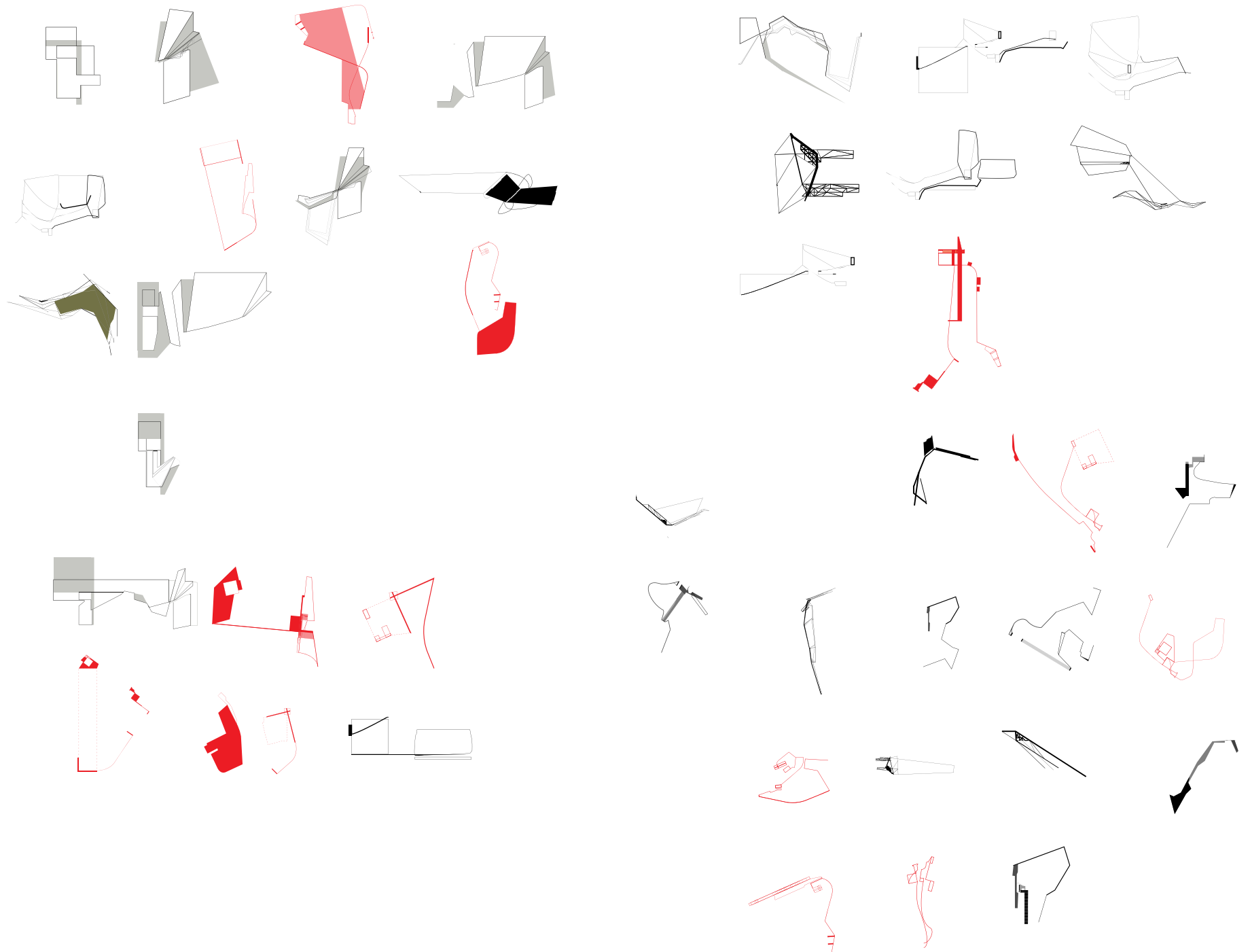

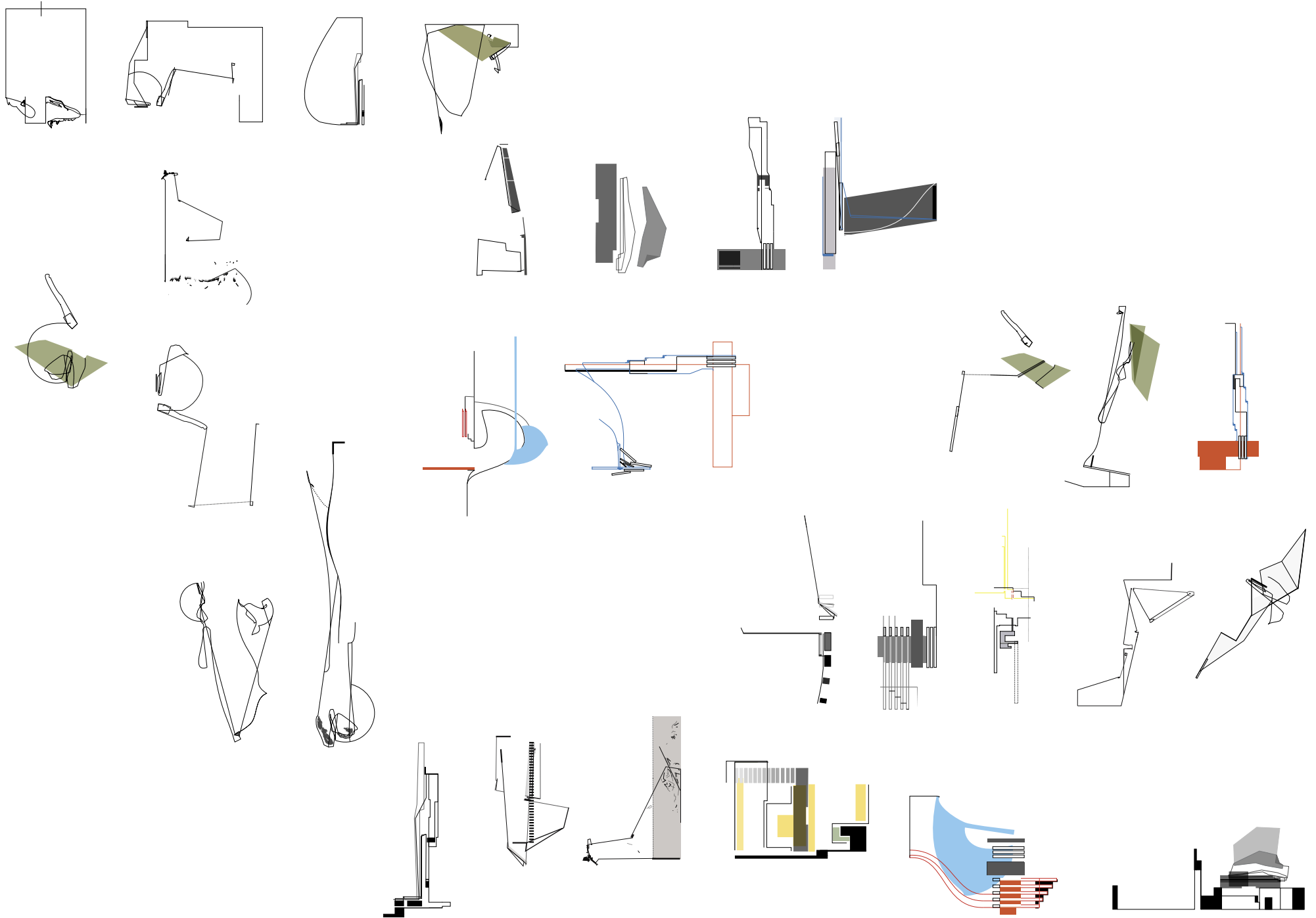

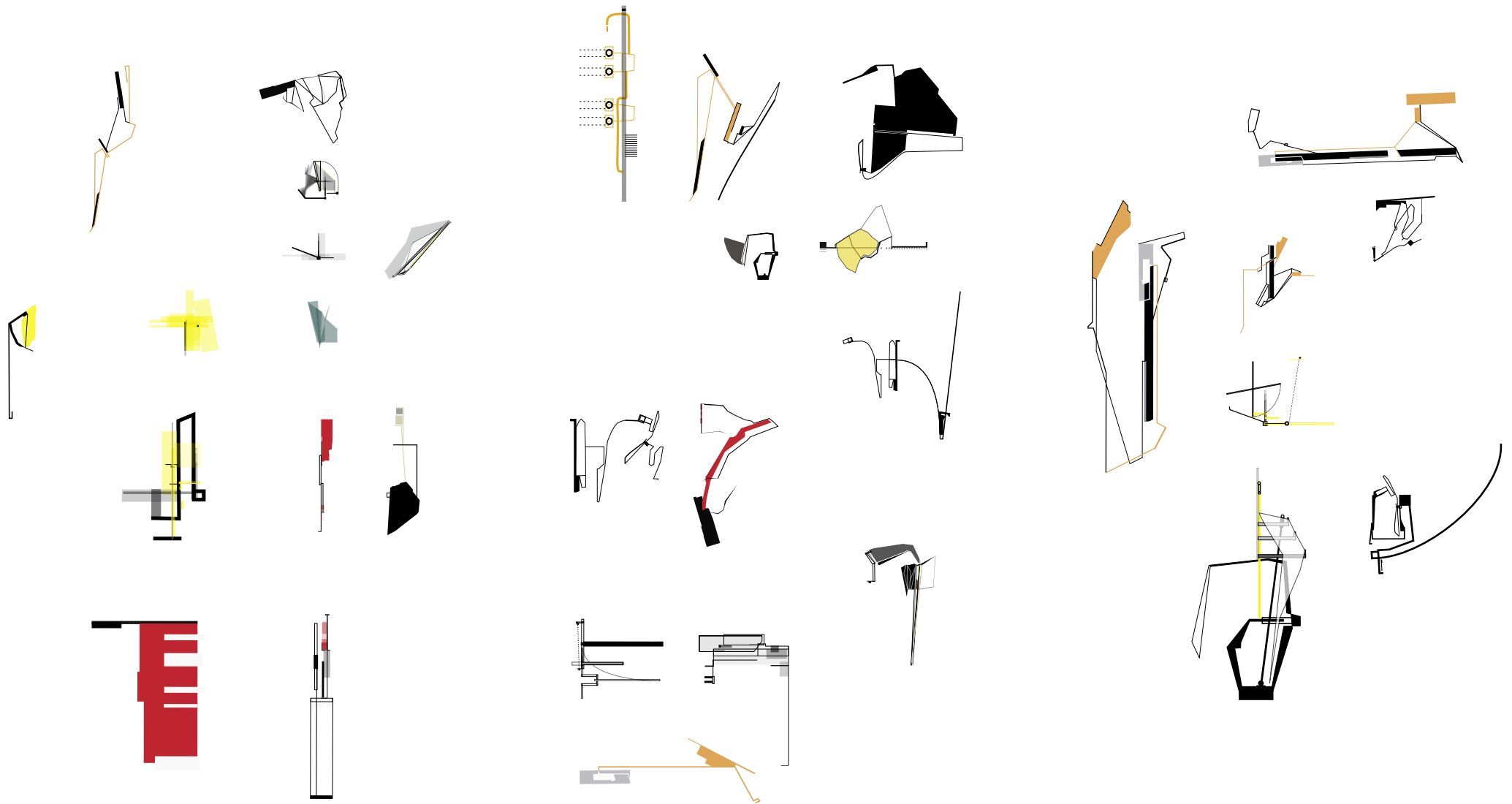

15. marts 2006

- Konstruer en tegning der placerer sig midt mellem alle de beskrevne tilstande. Undgå at en særlig tegning privilegeres som udgangspunkt. (der bør ikke være én konfiguration, der låser materialet således, at der formuleres en "struktur")

Konstruktionen bør kunne iagttages så den udtrykker og rummer sit "hele" potentiale.

(se opslaget "poly" fra Dictionary of Advanced Architecture)

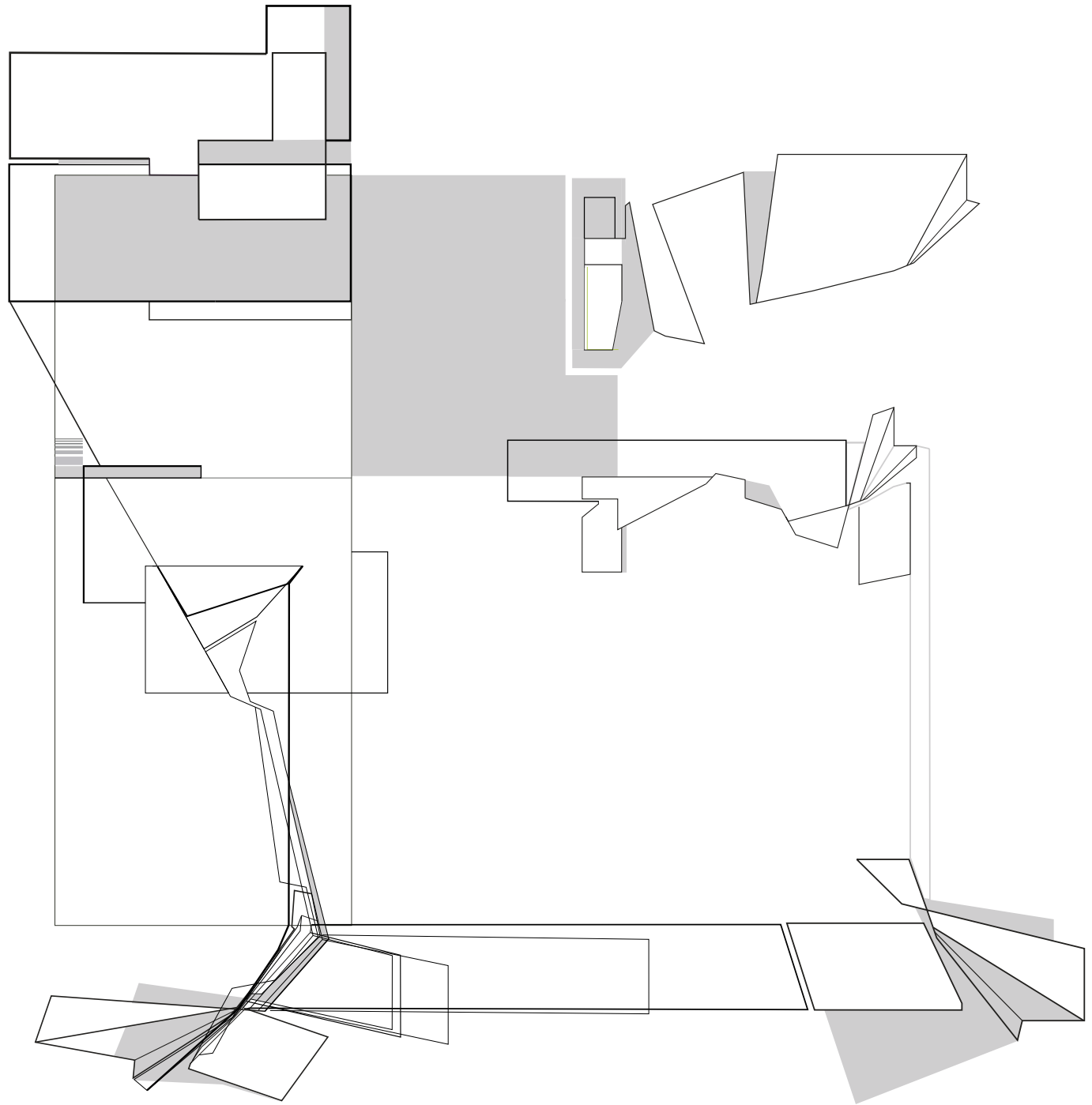

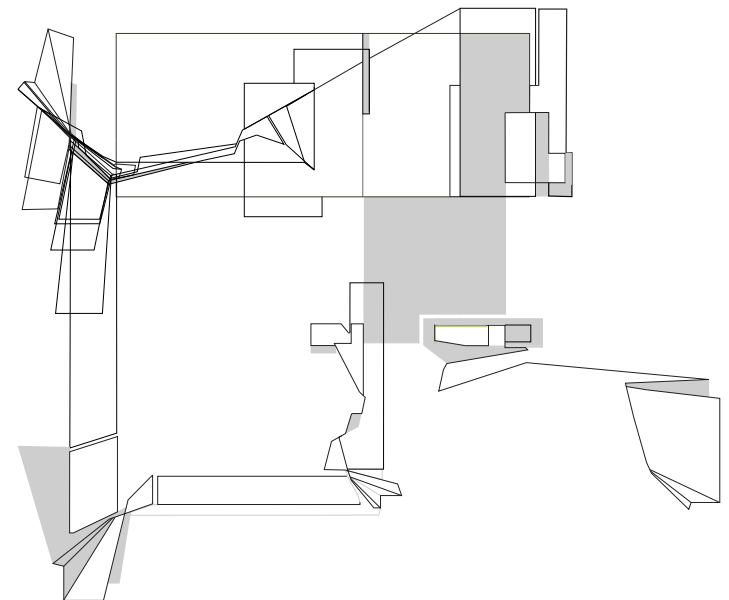
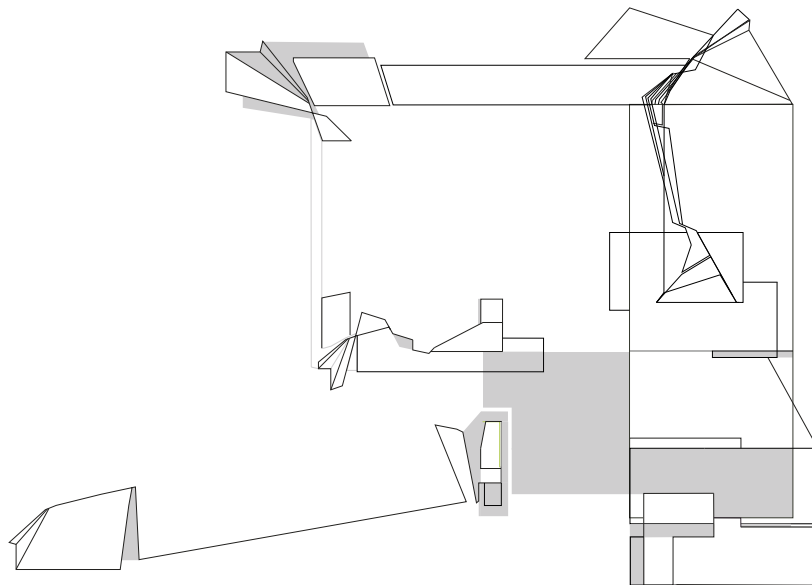
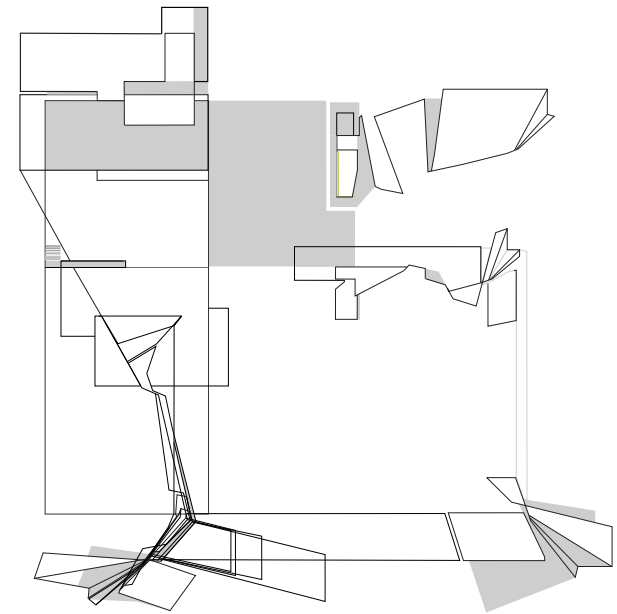
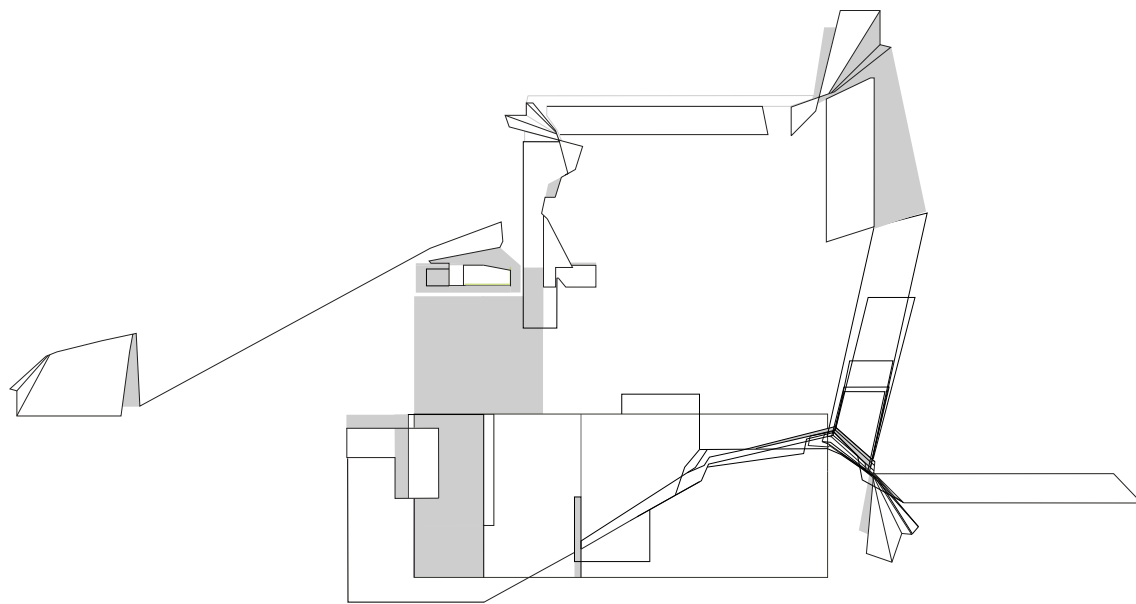

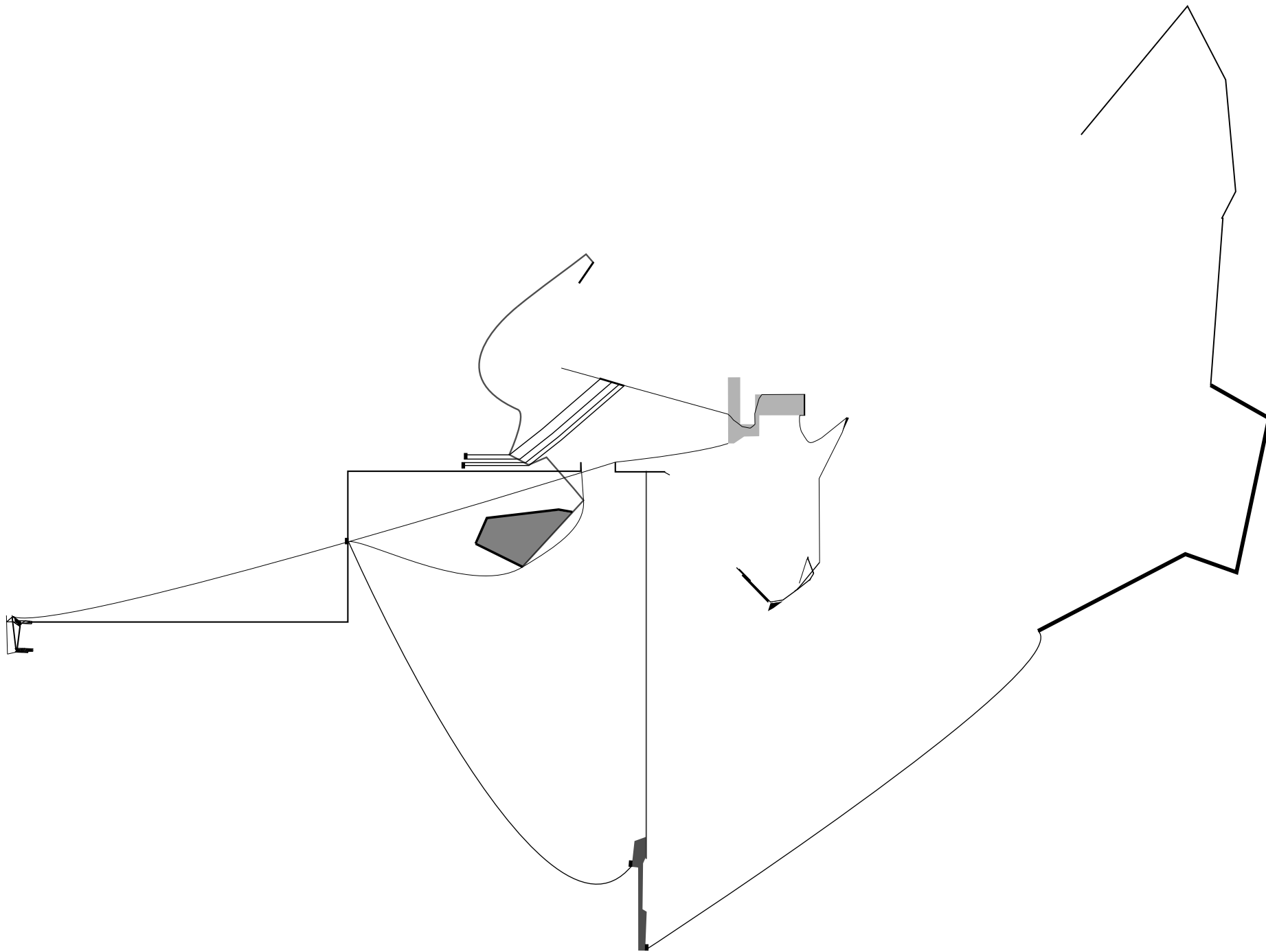

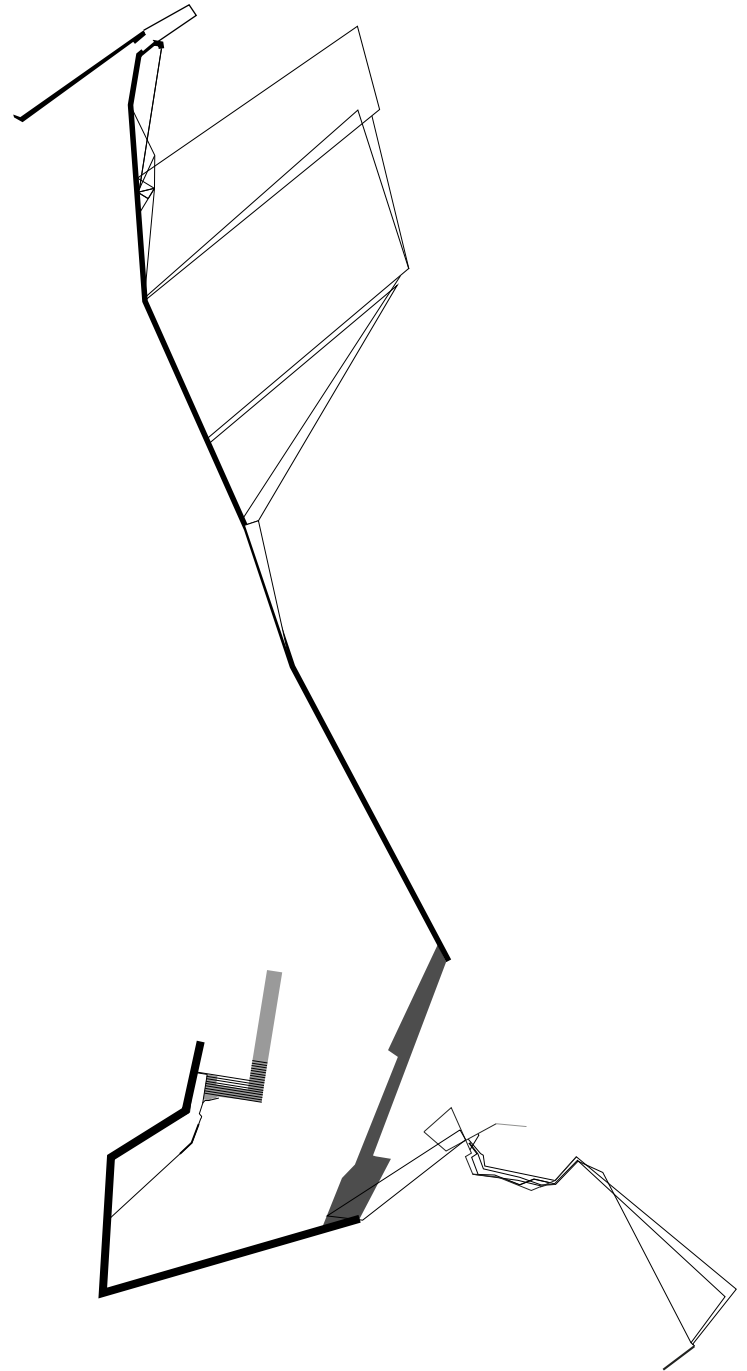

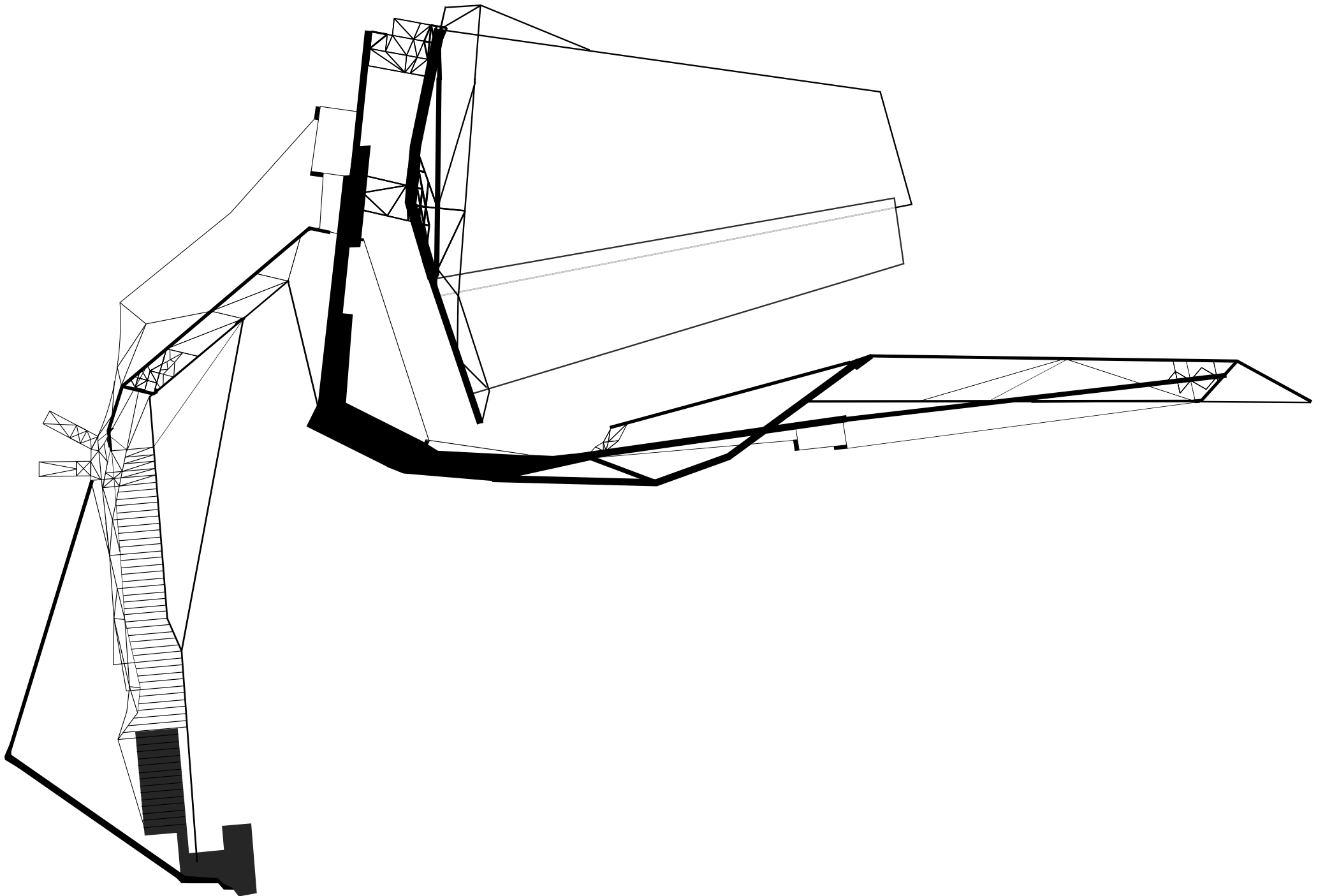

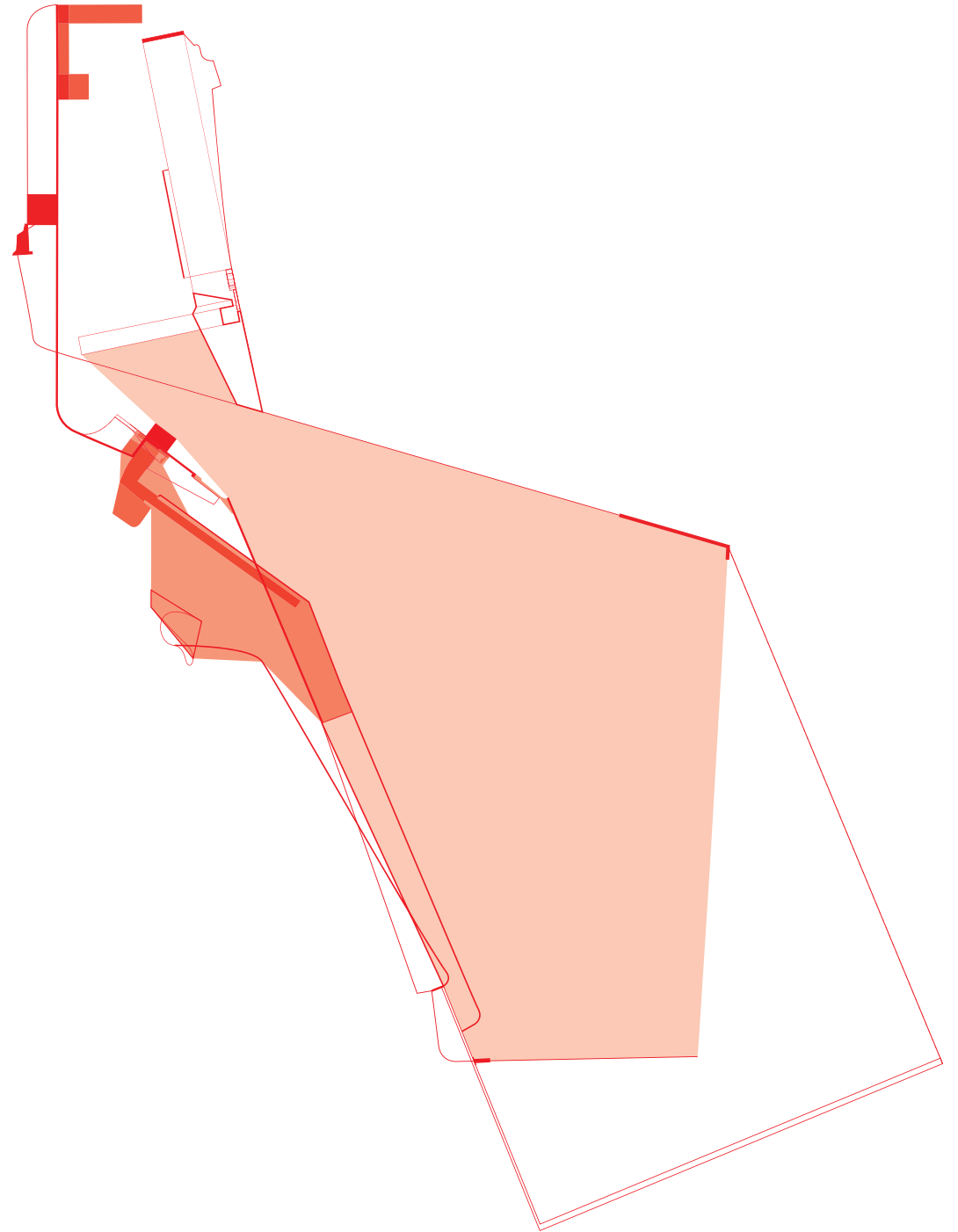

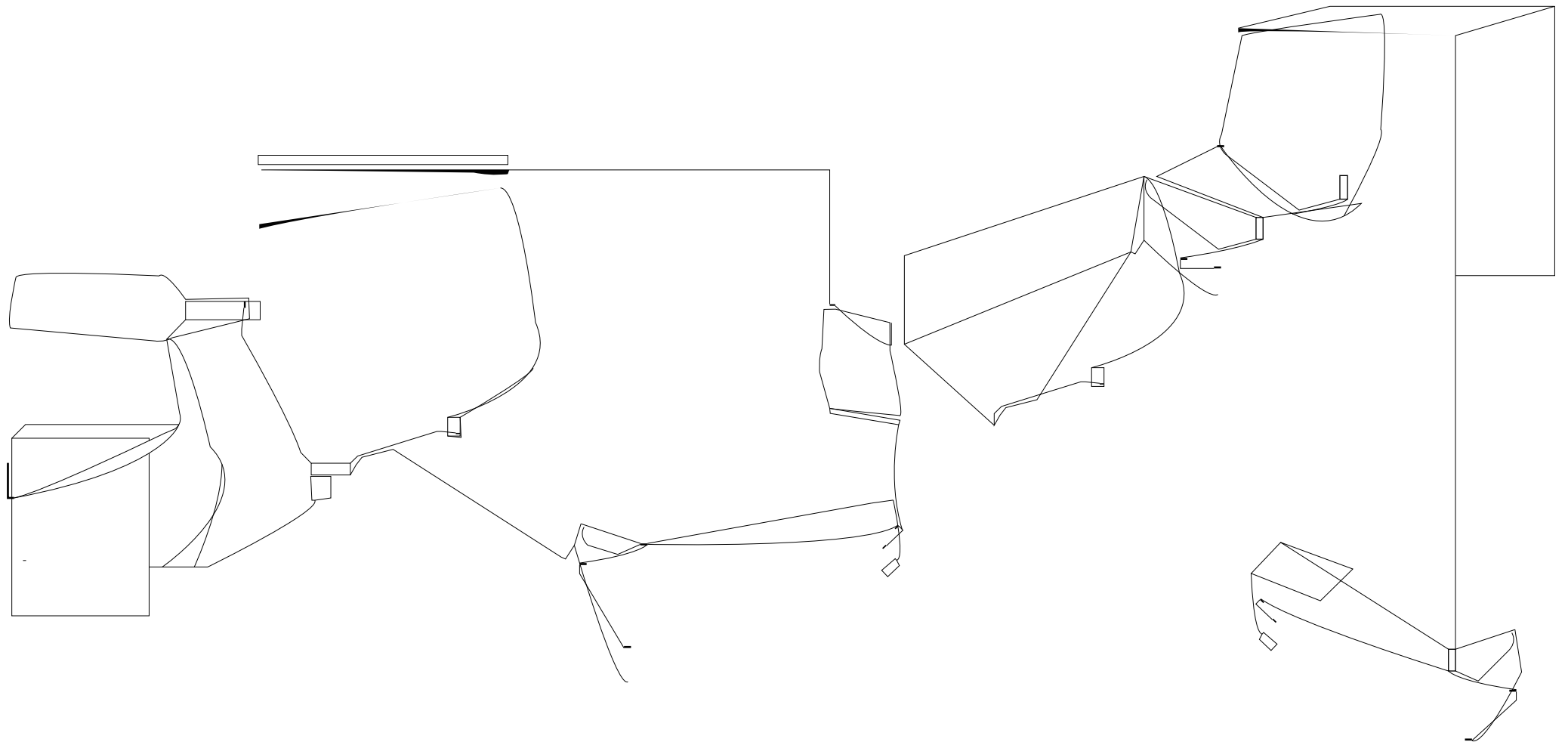

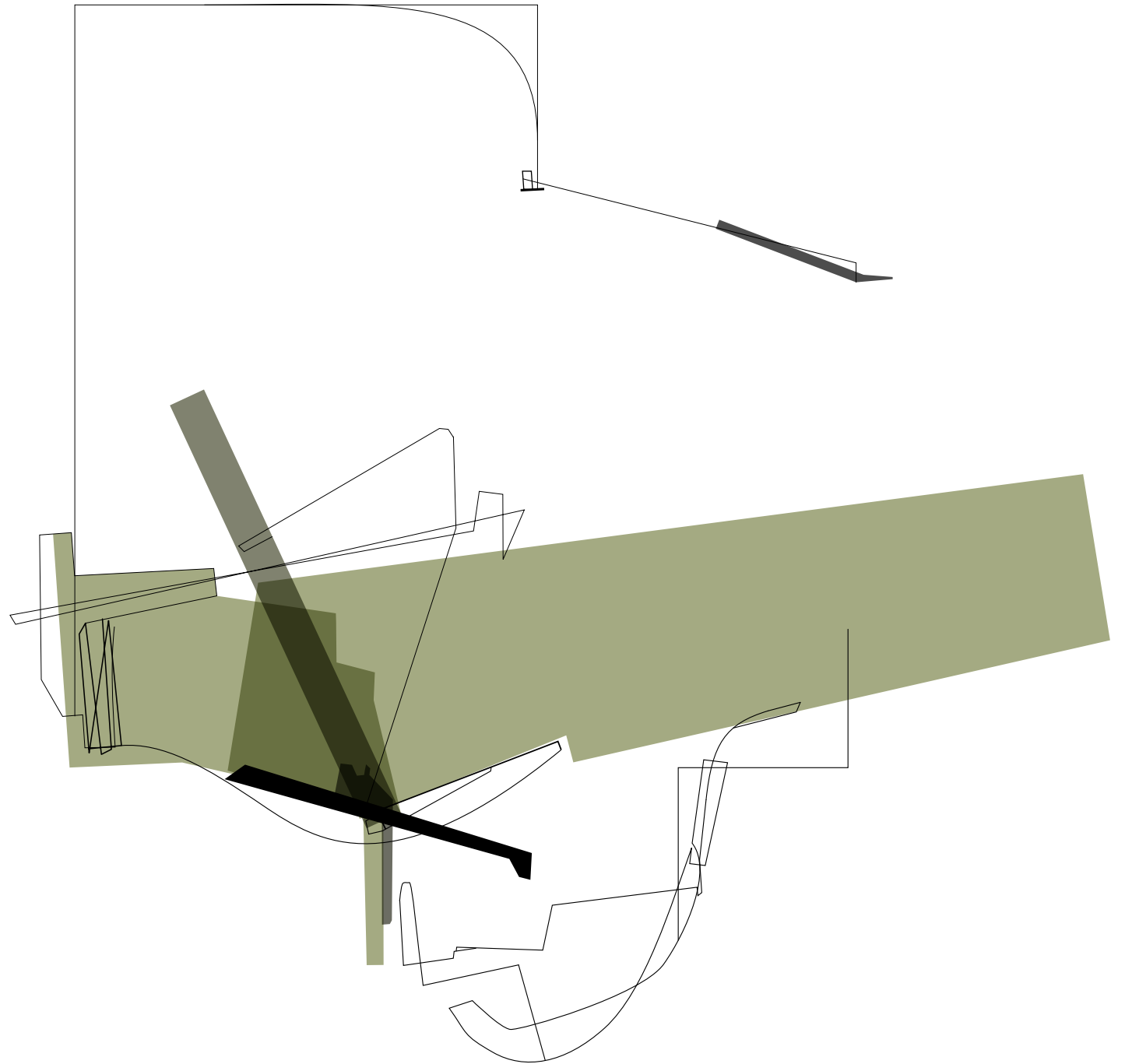

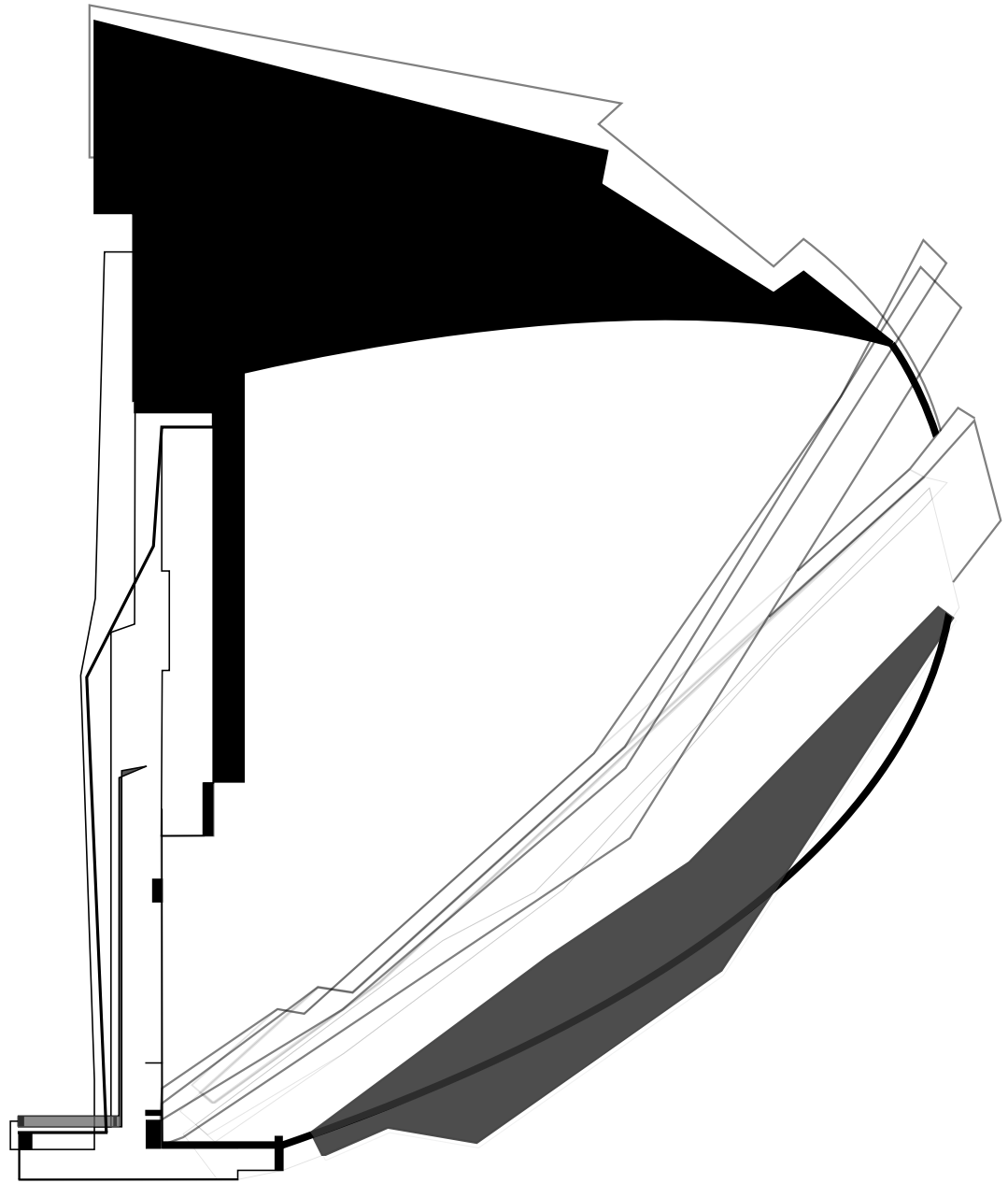

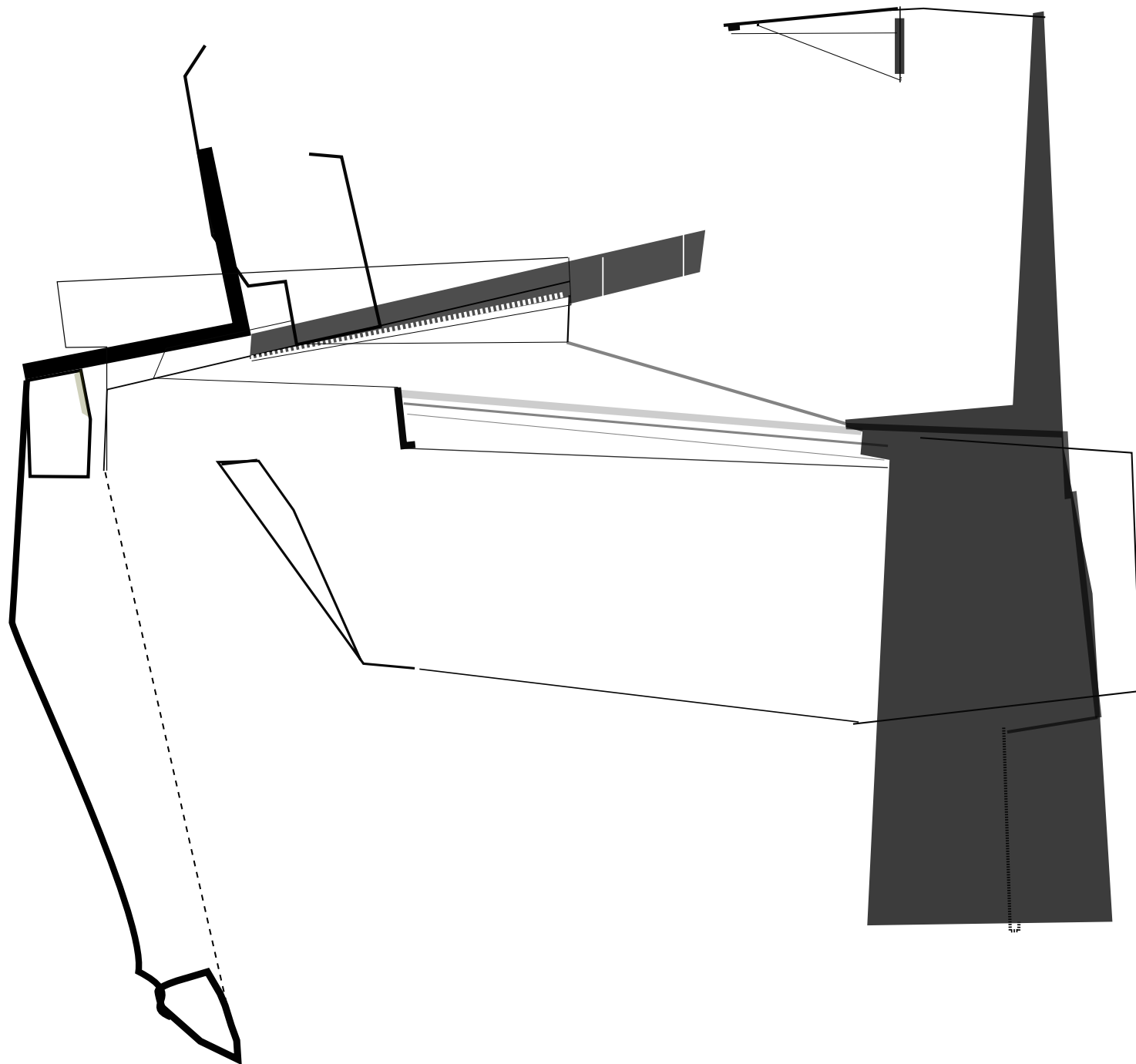

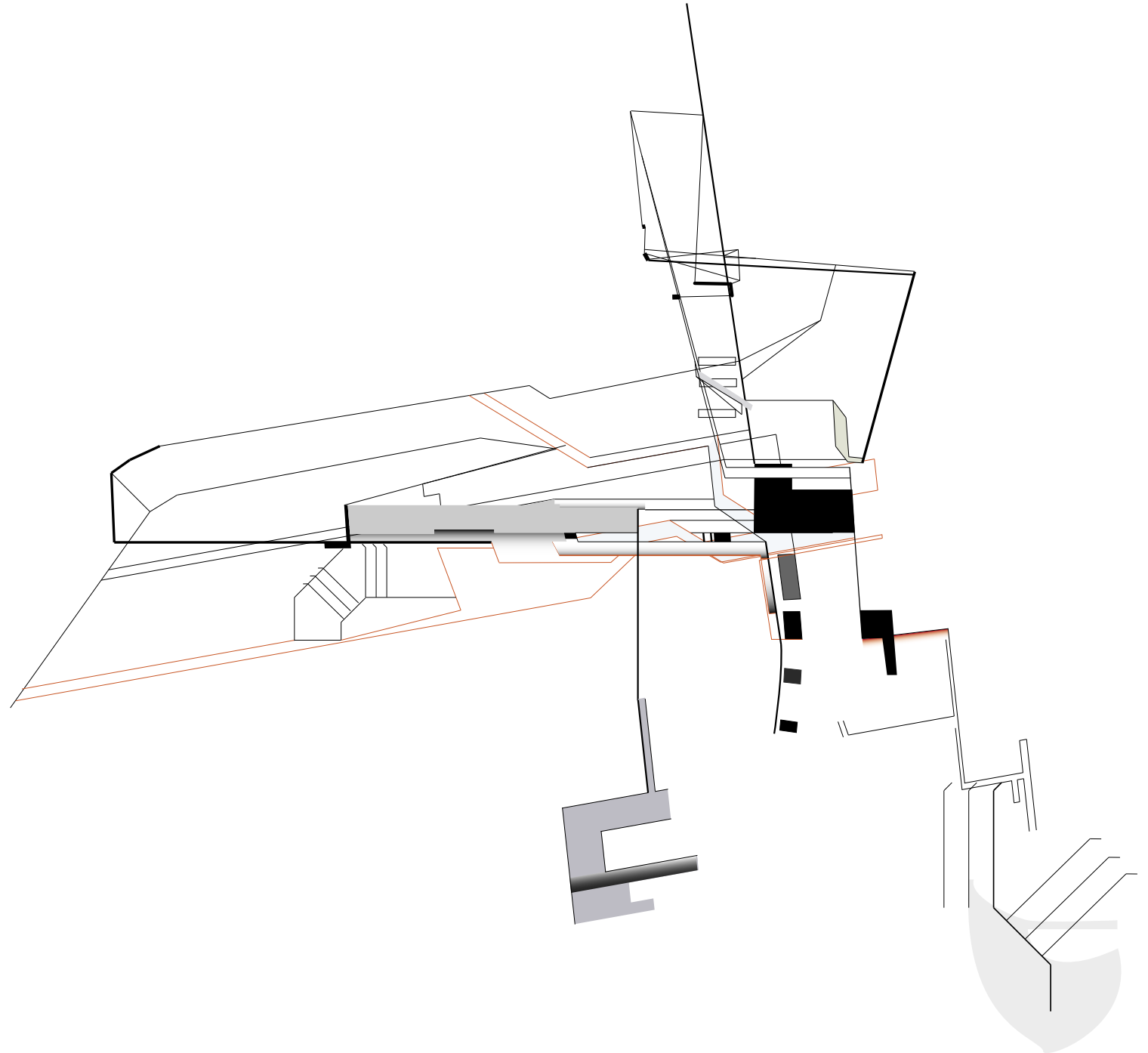

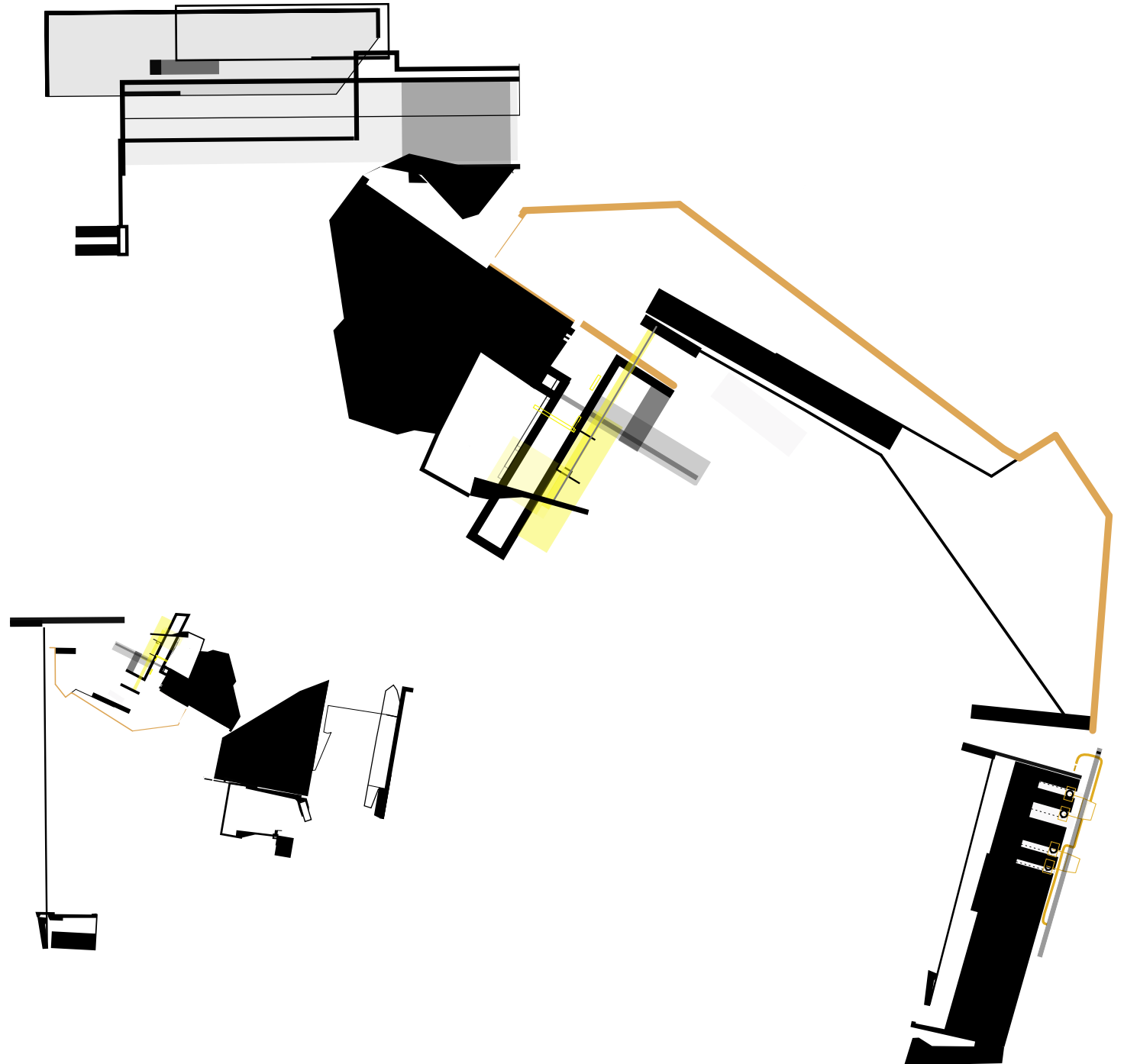

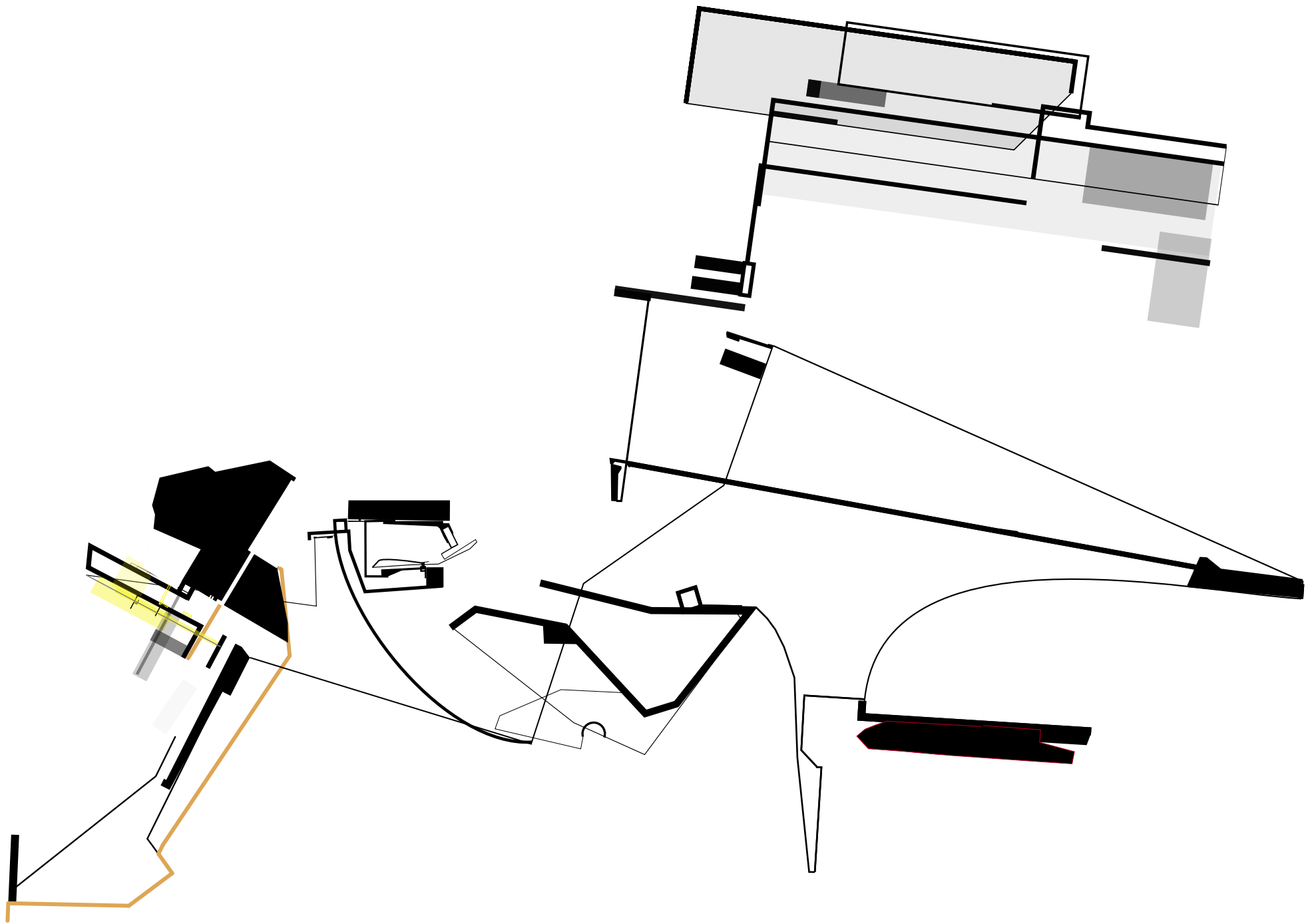

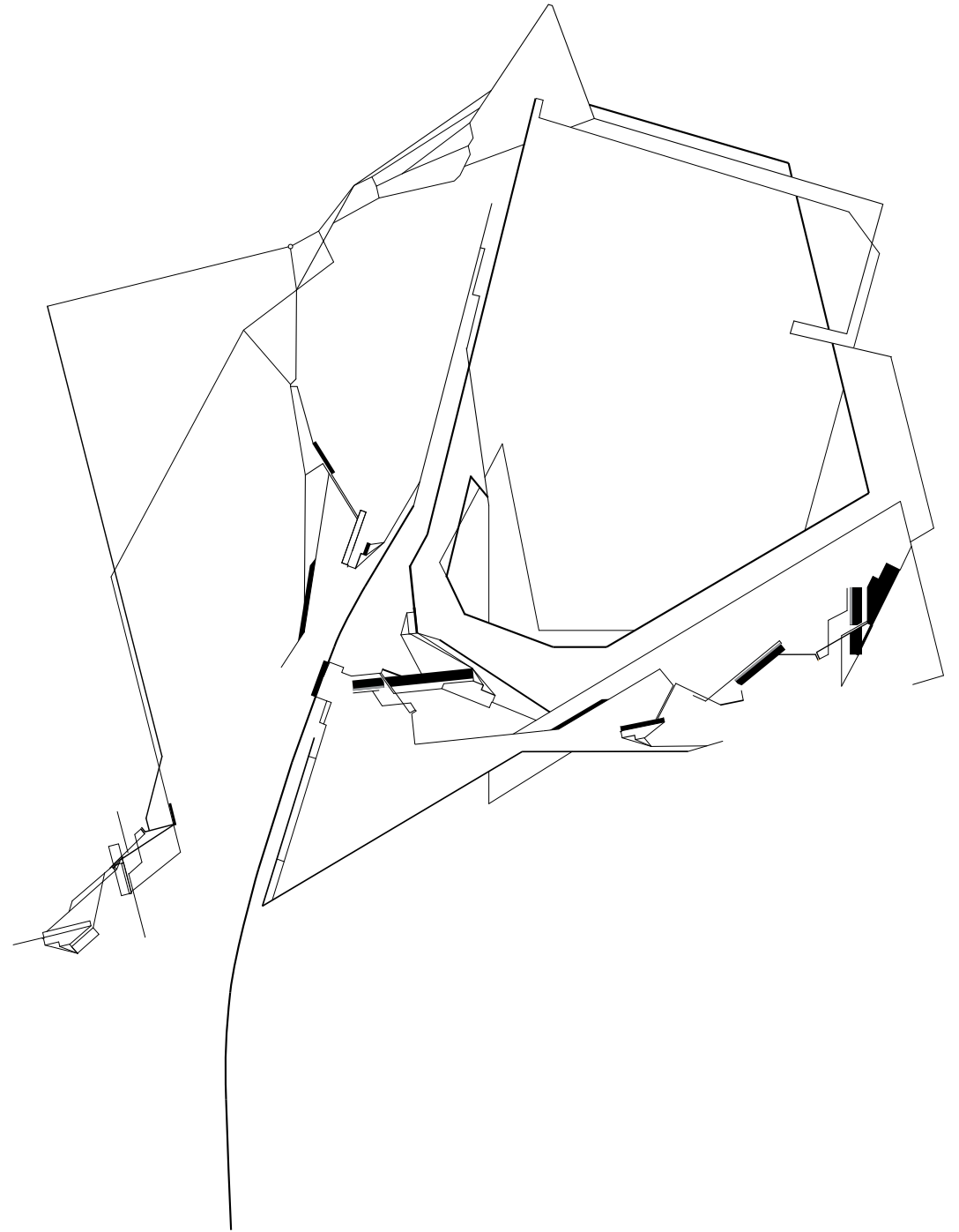

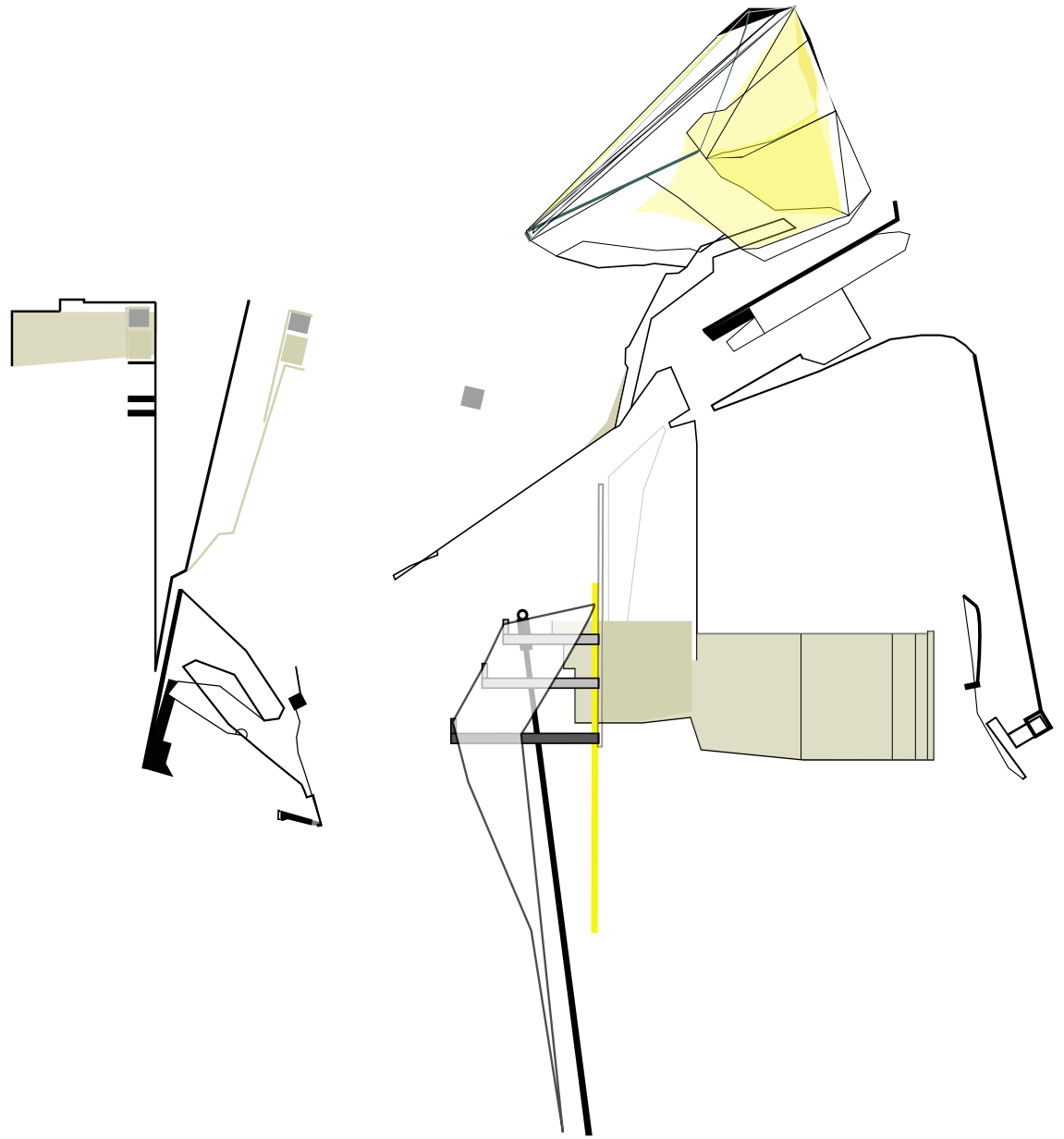

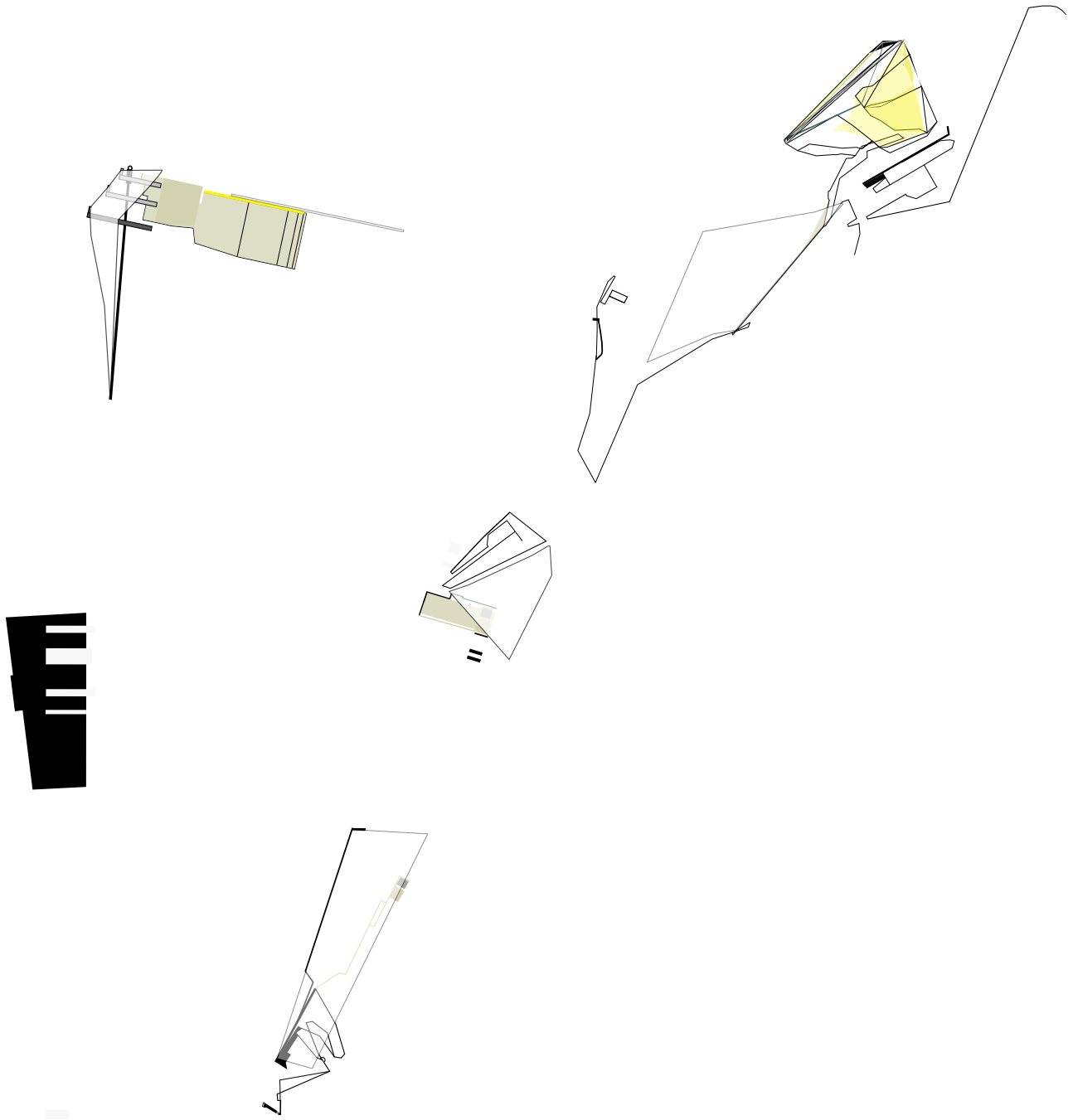

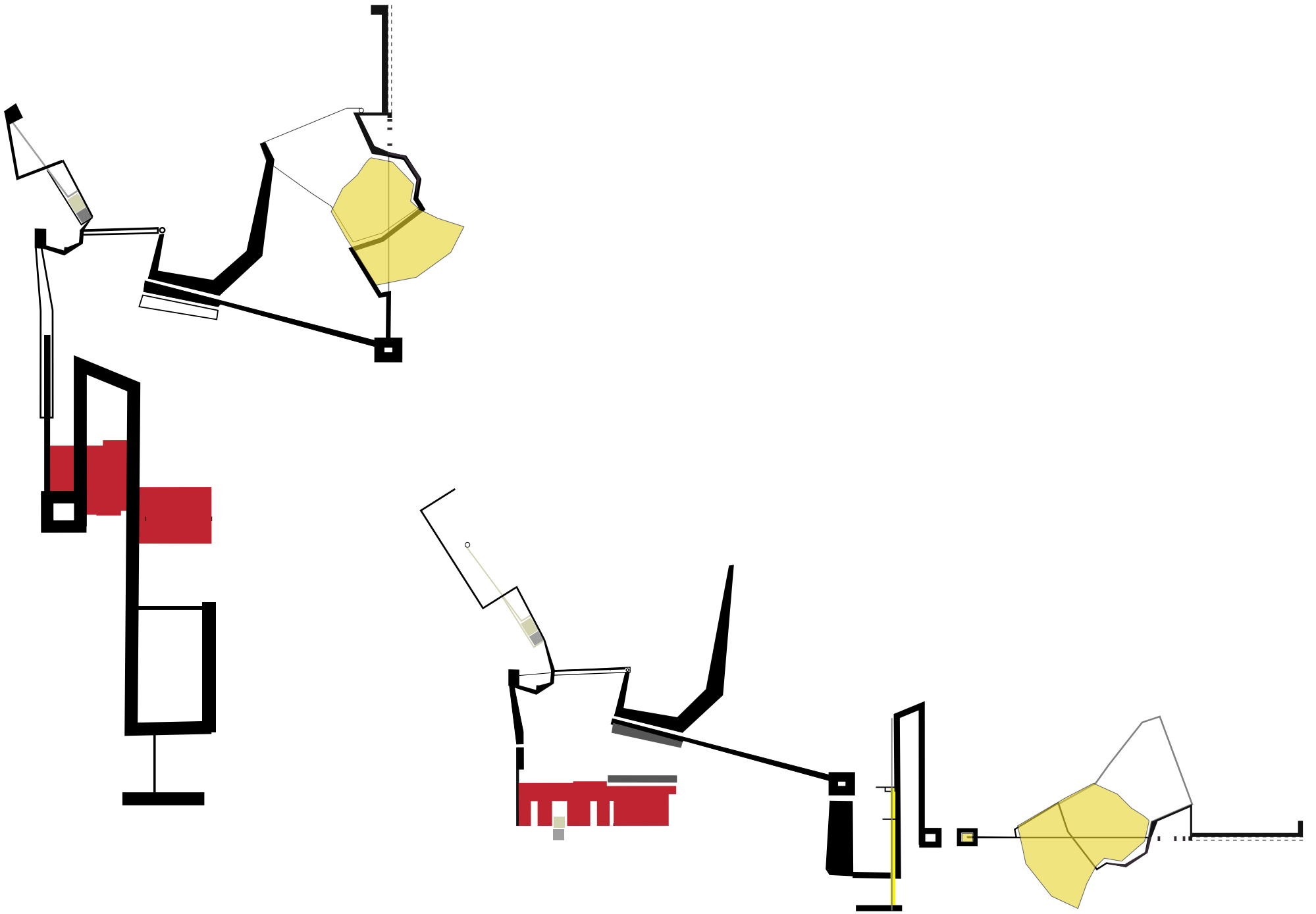

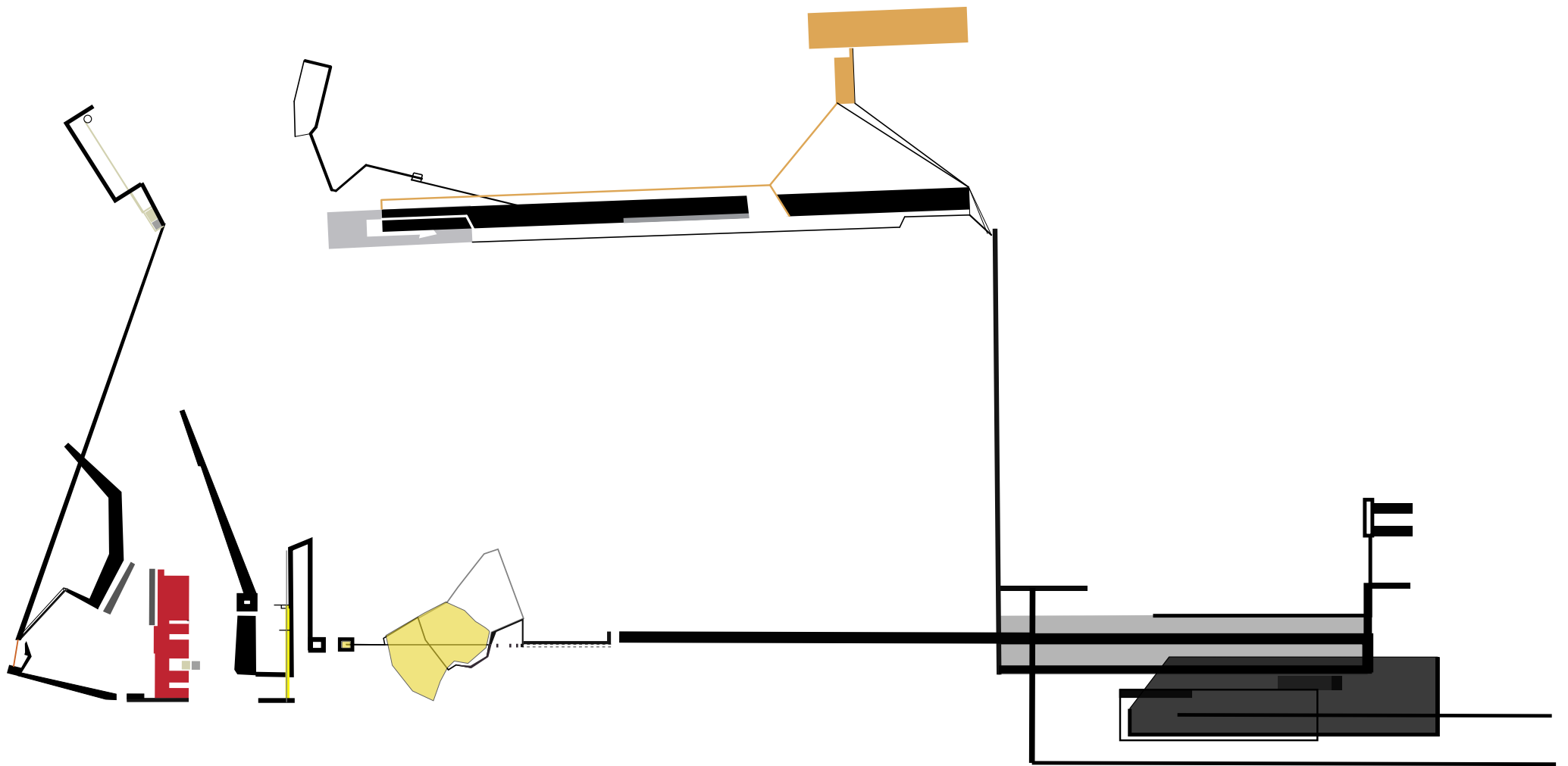

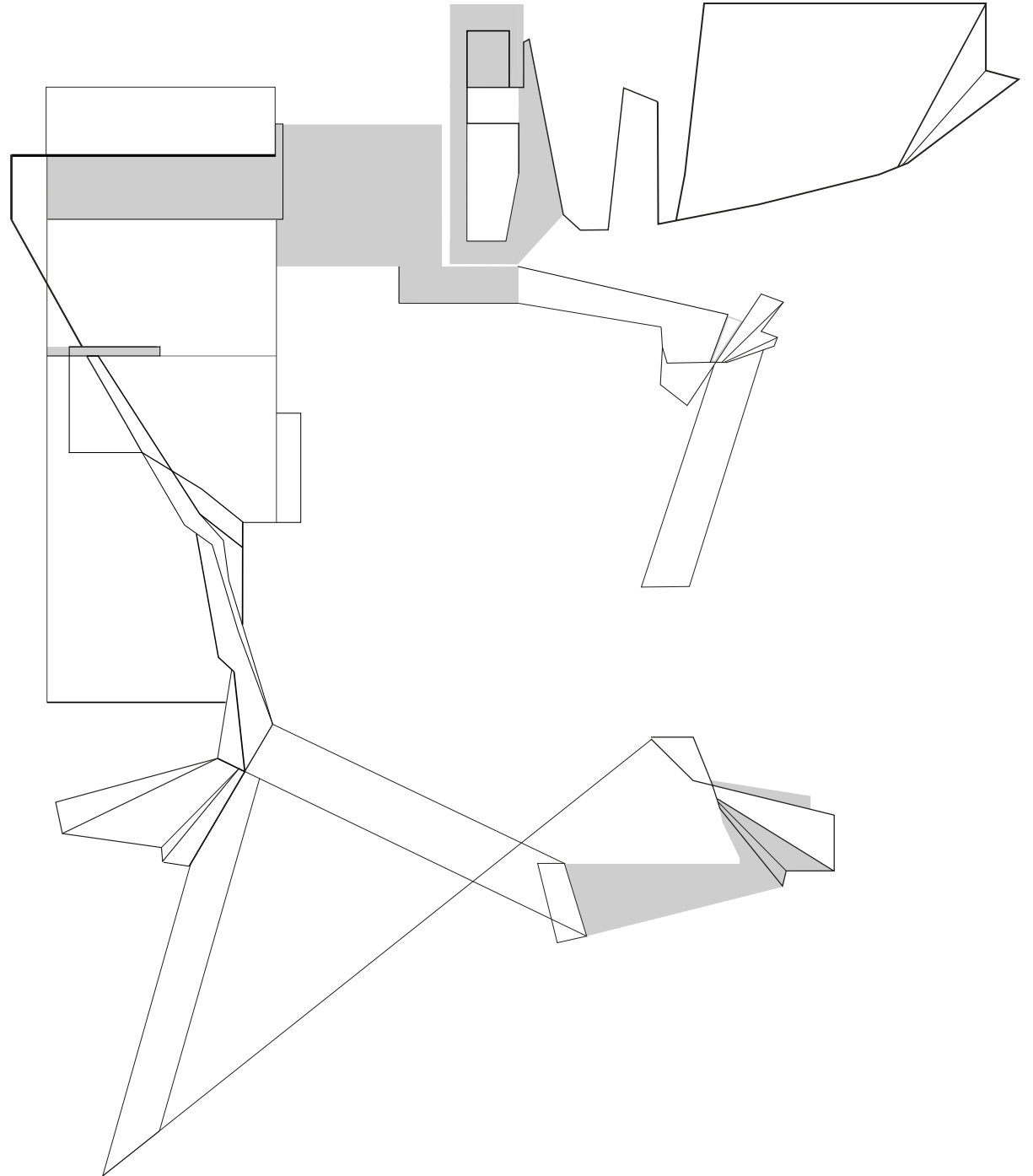

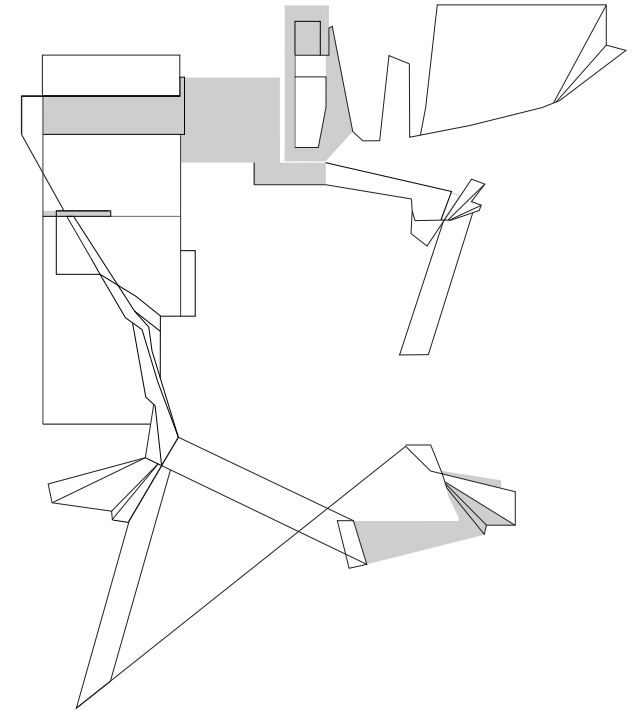
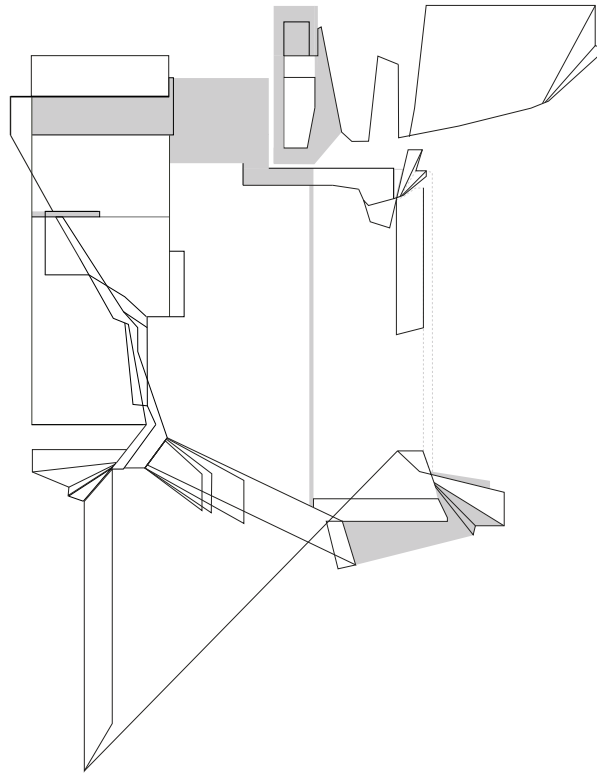
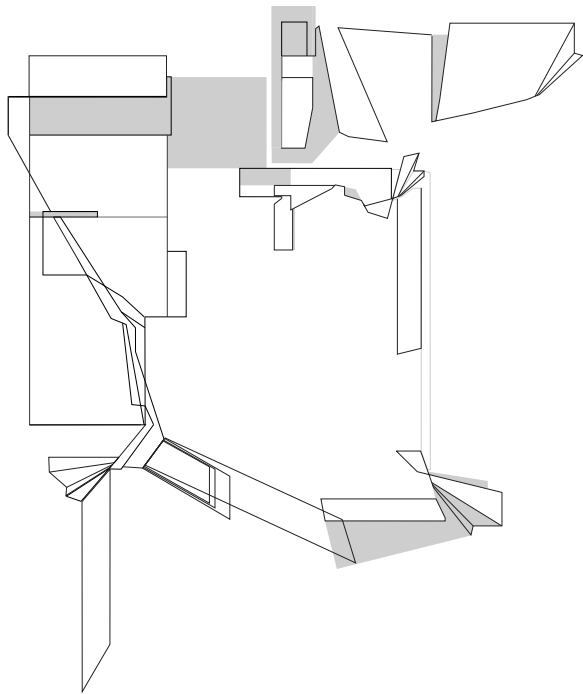

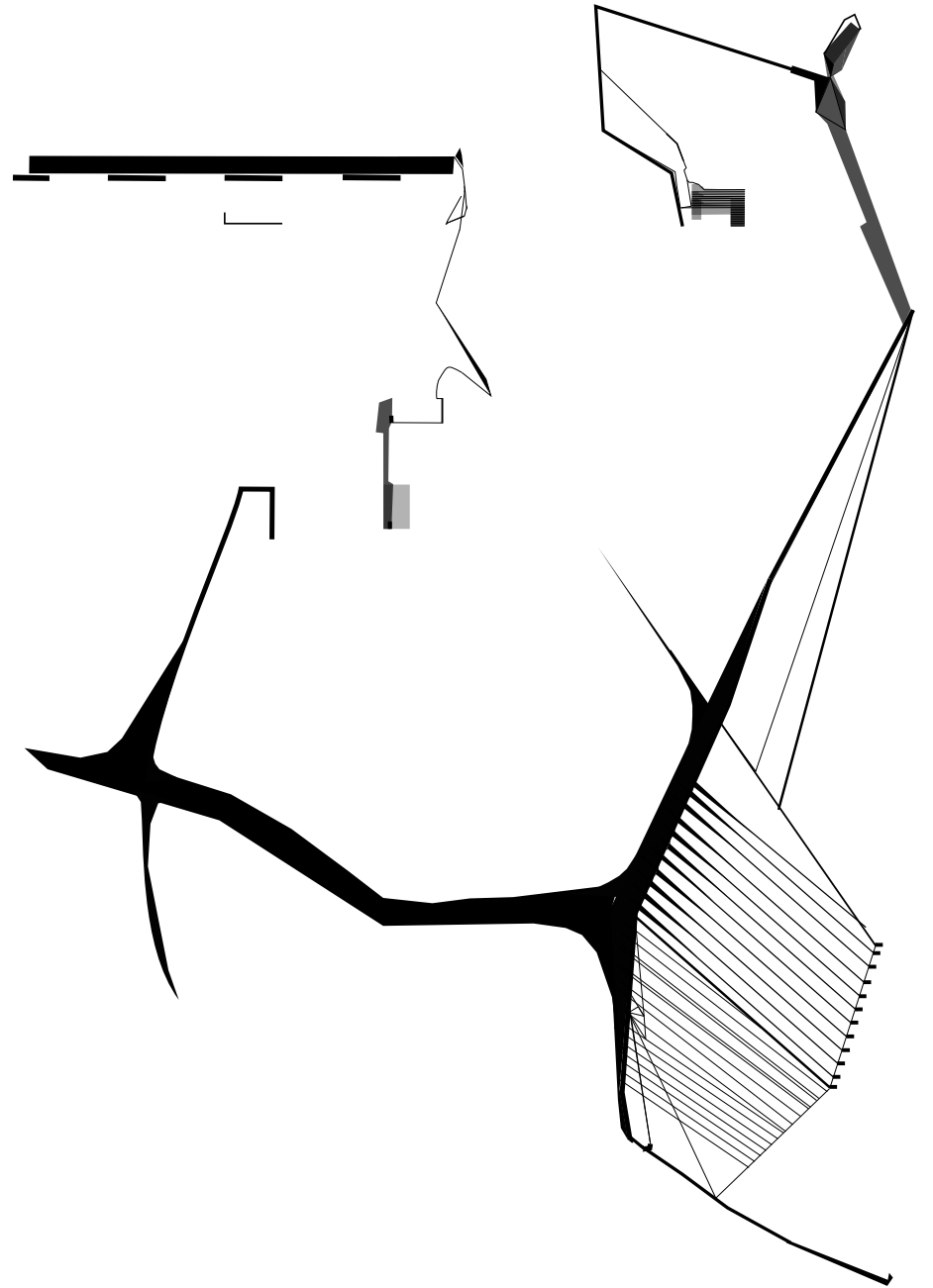

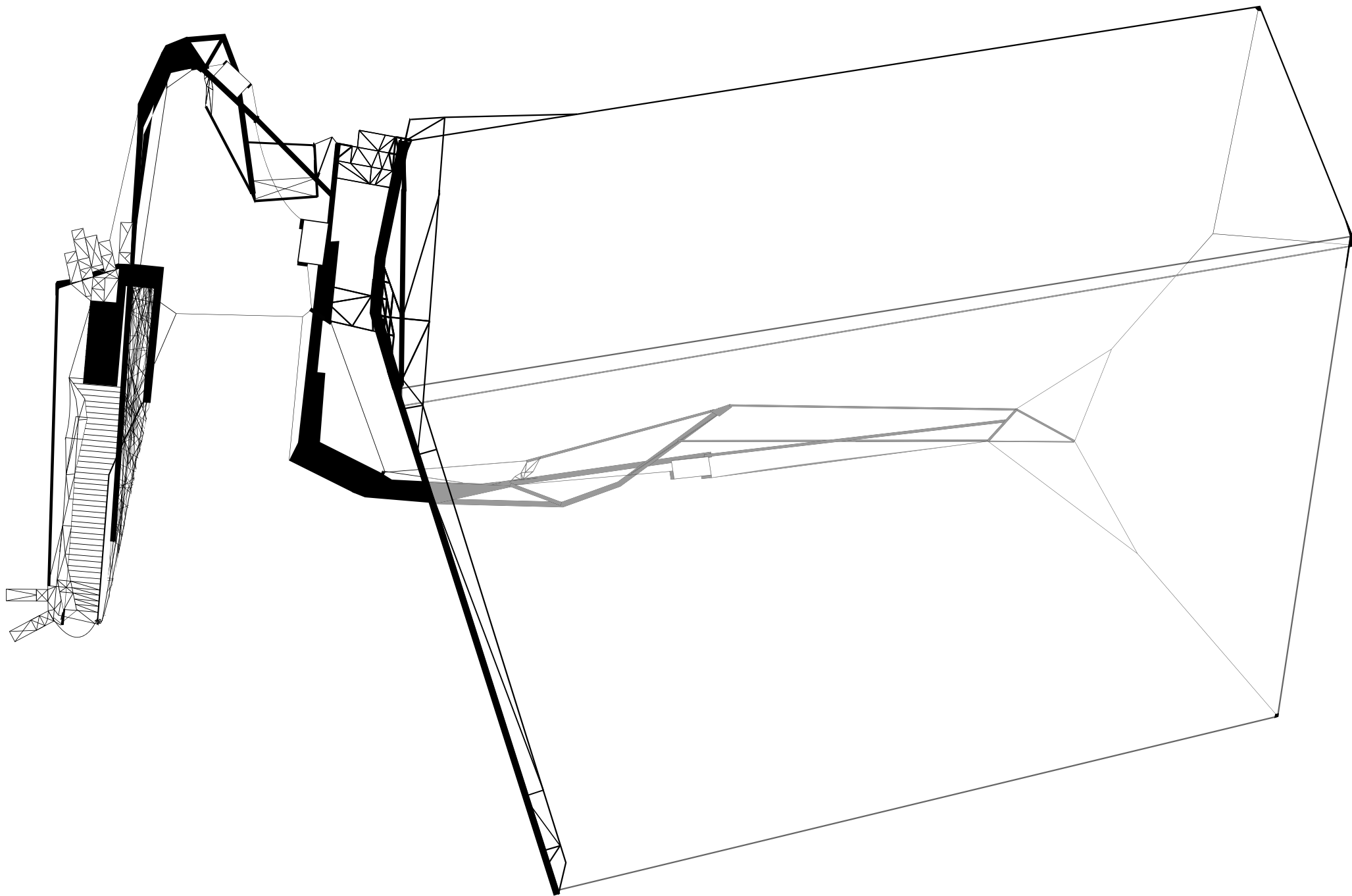

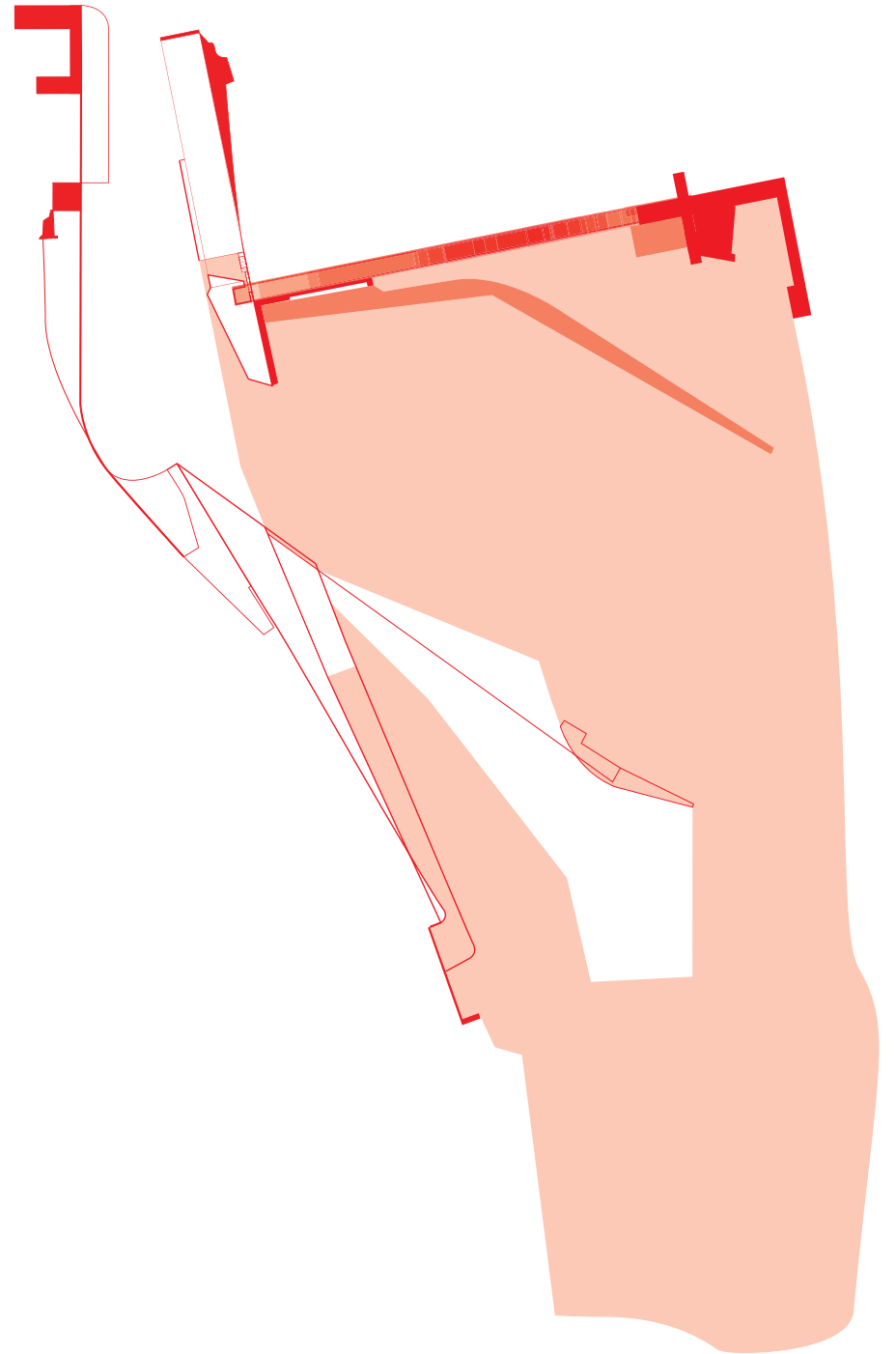

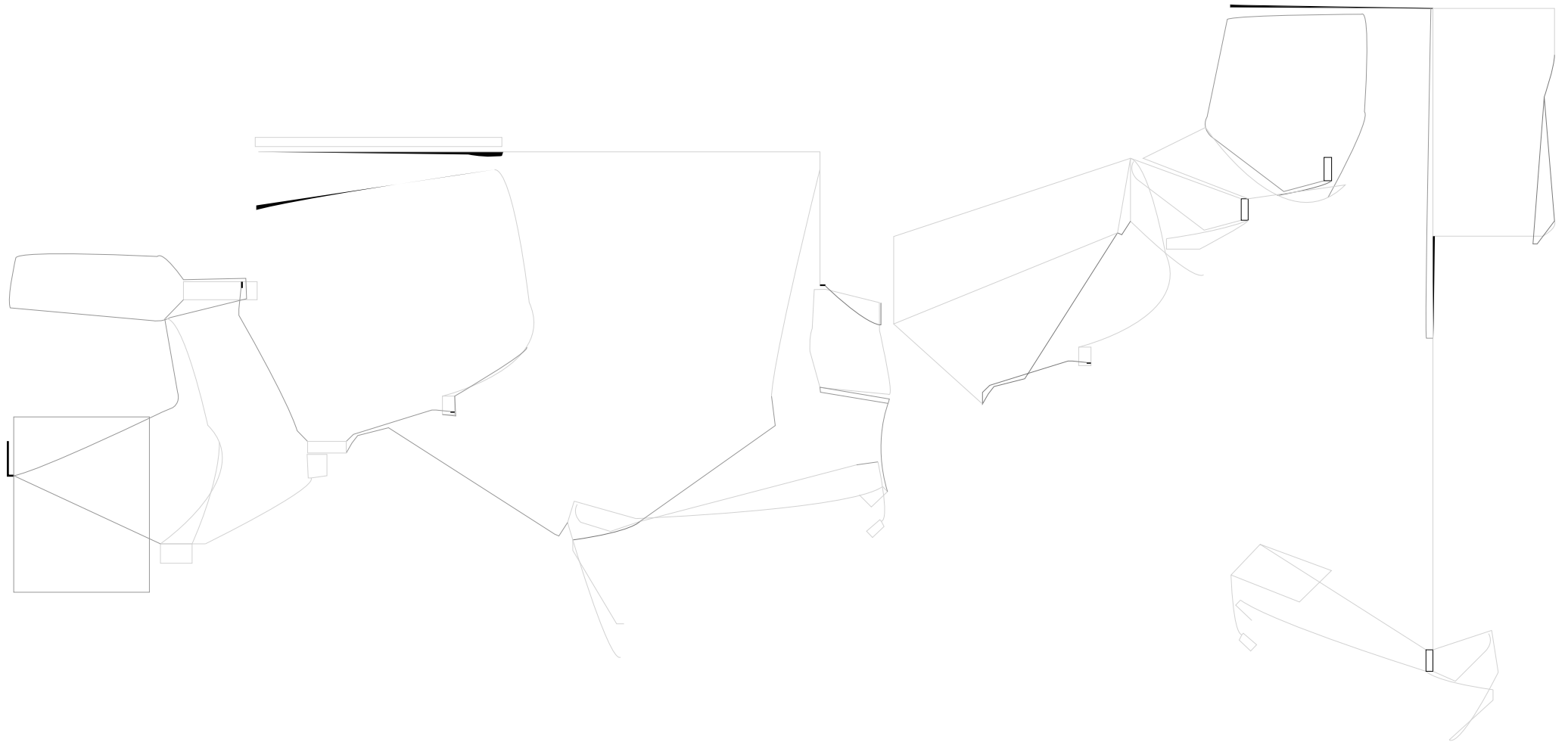

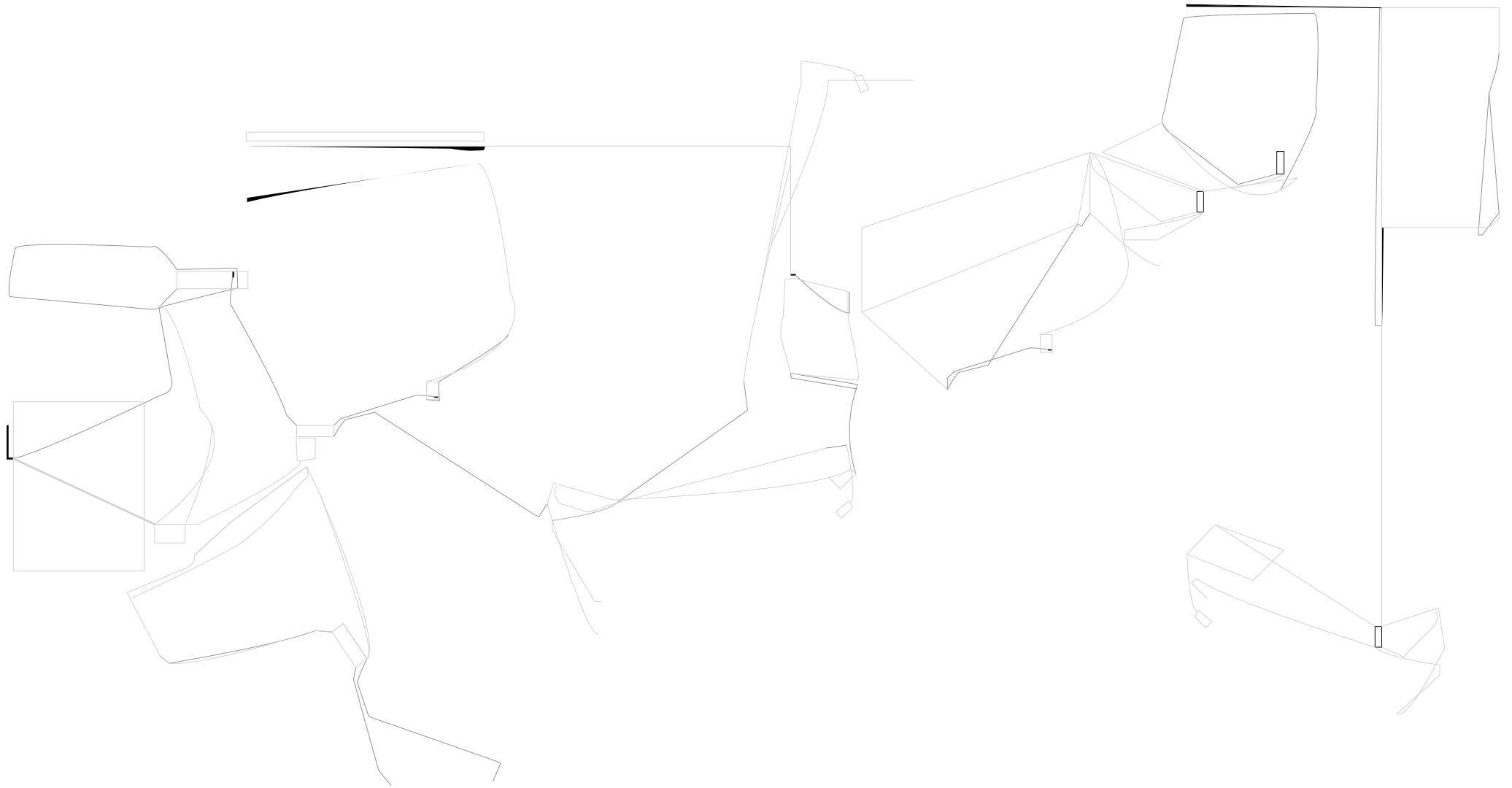

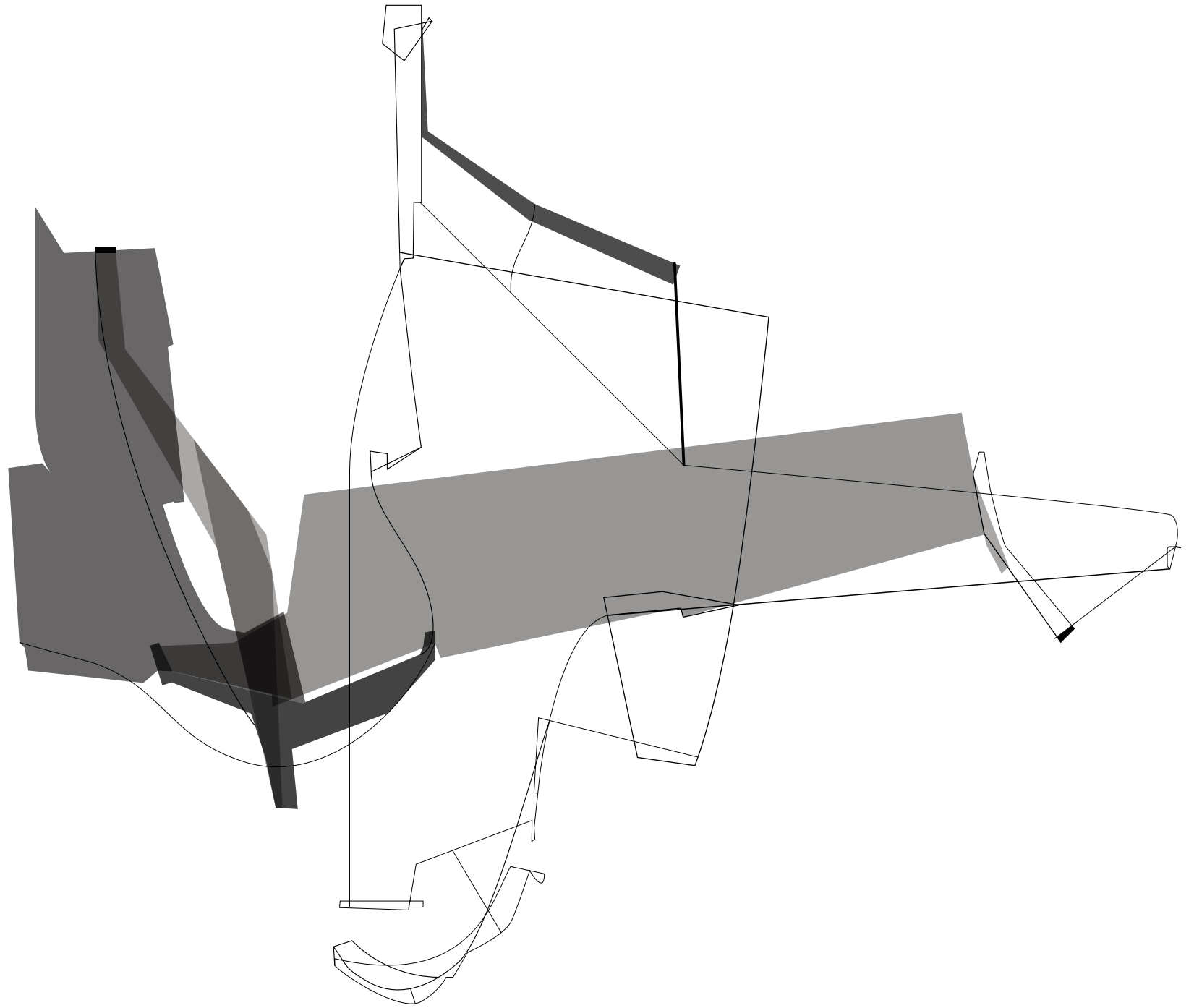

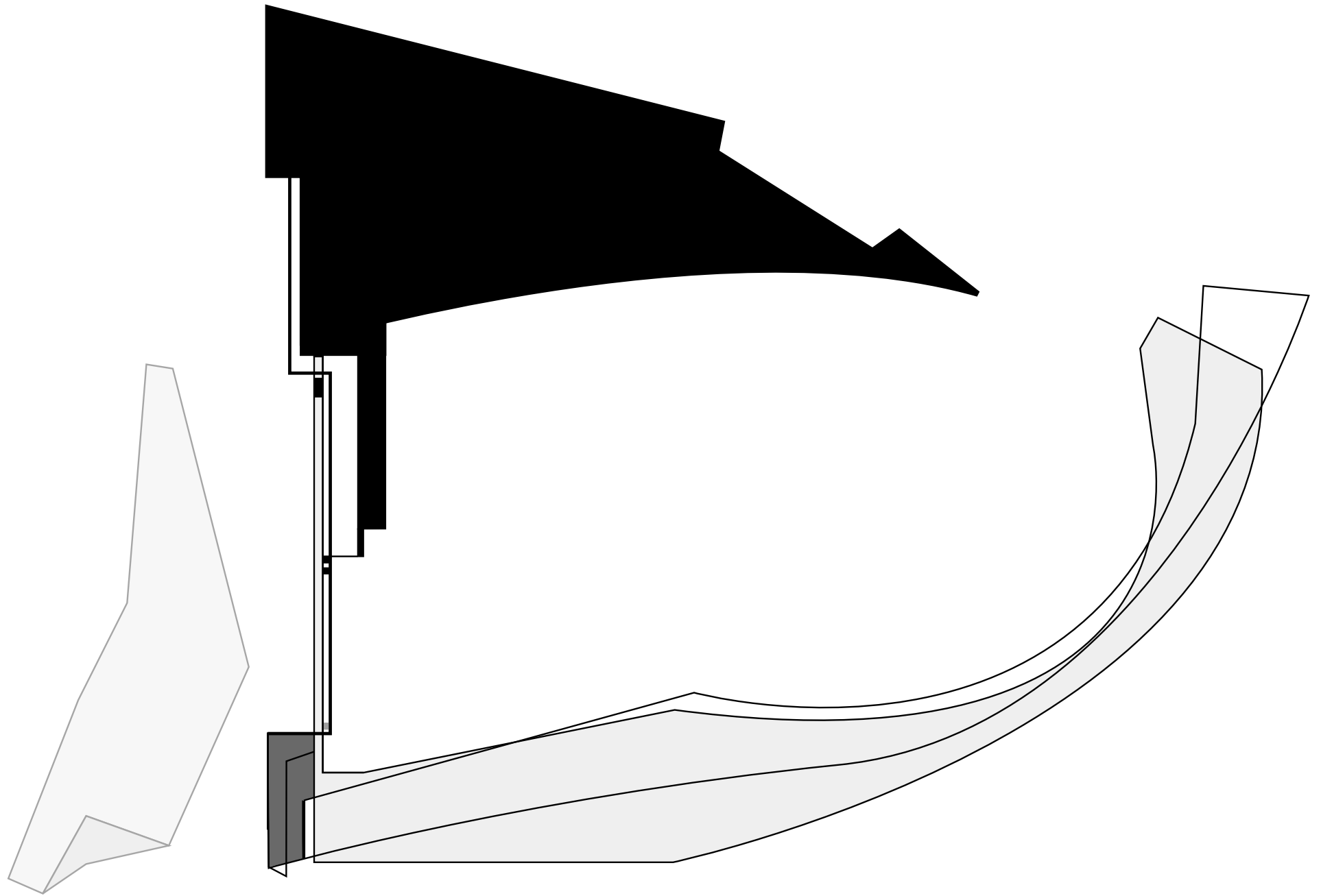

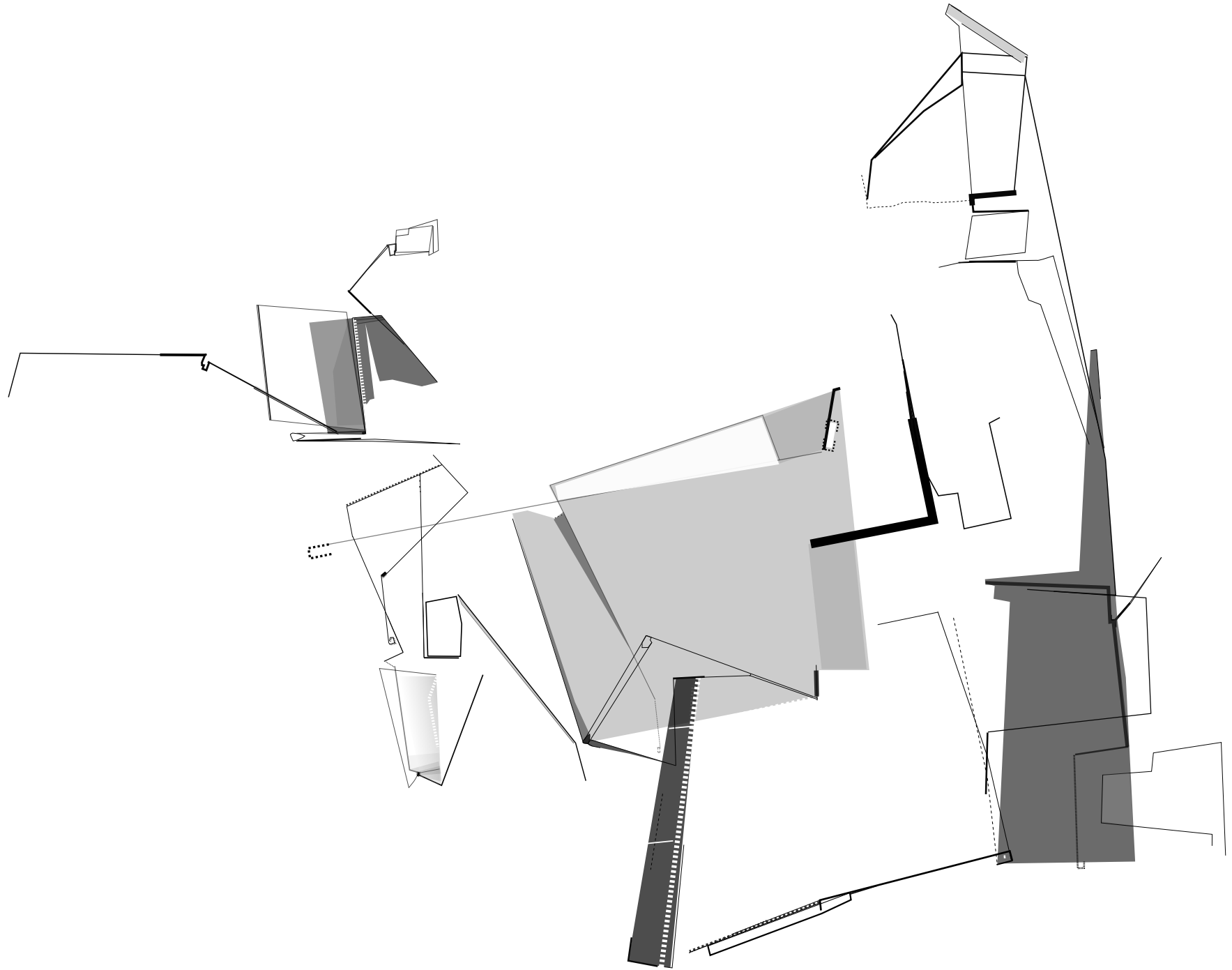

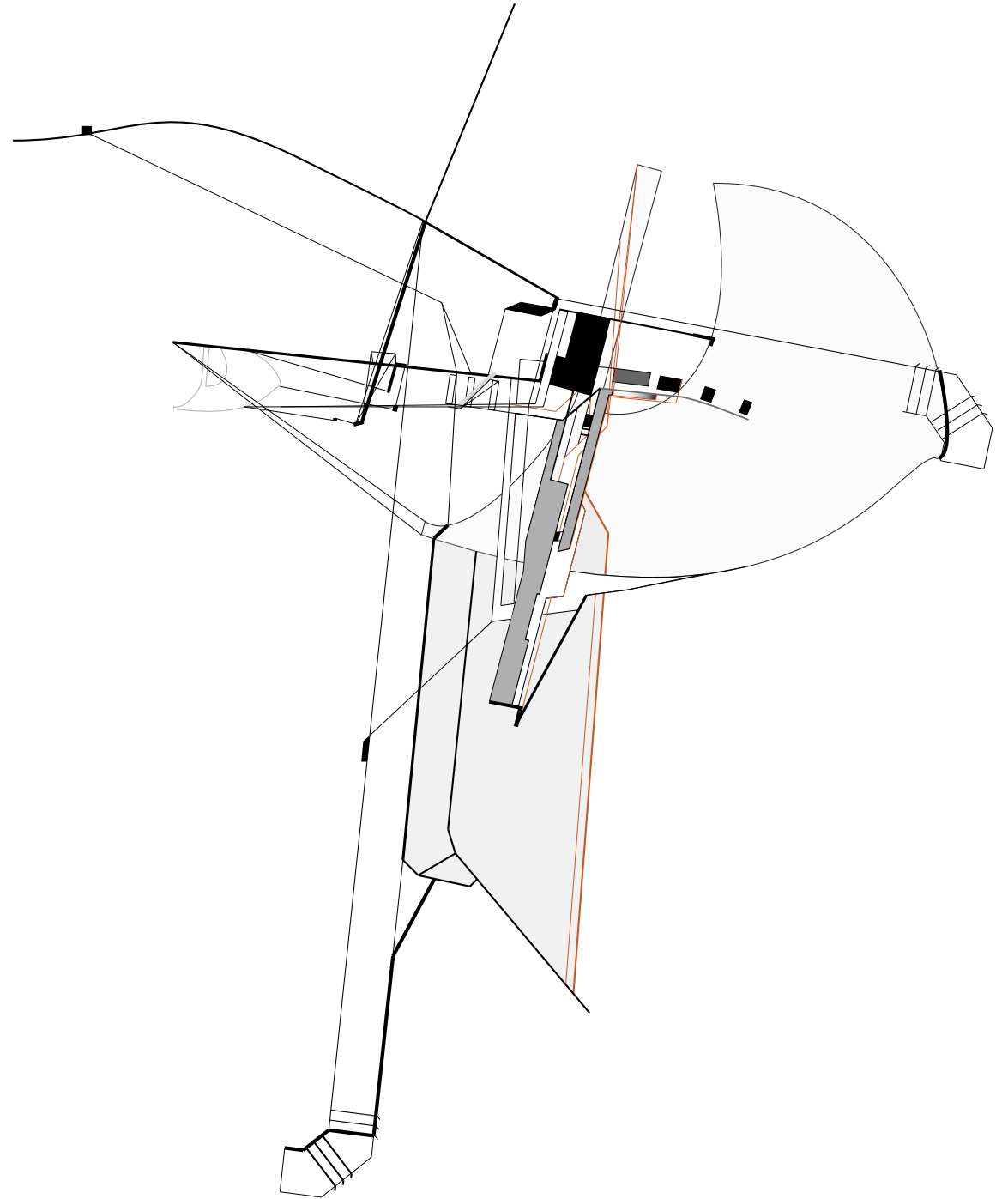





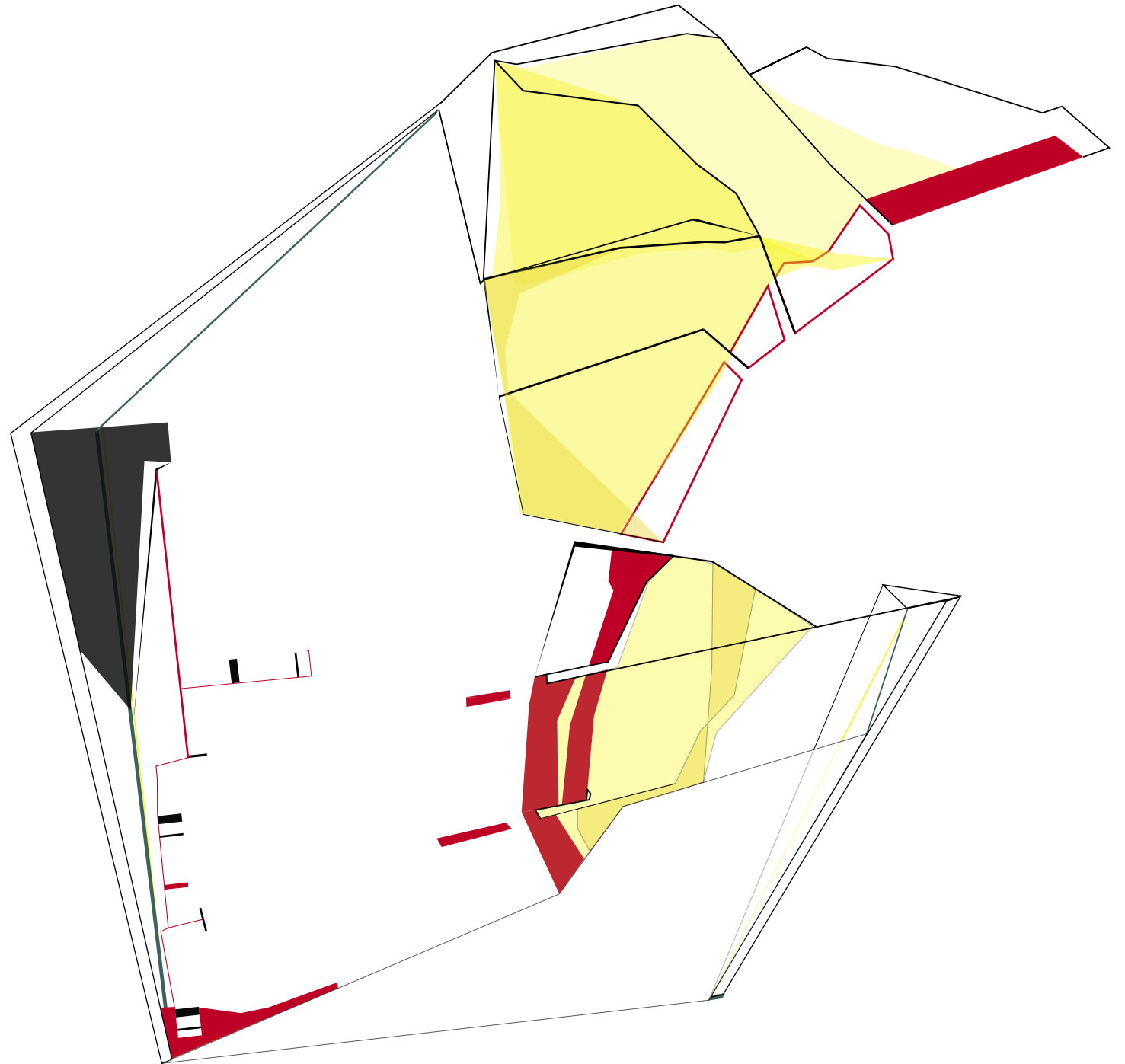

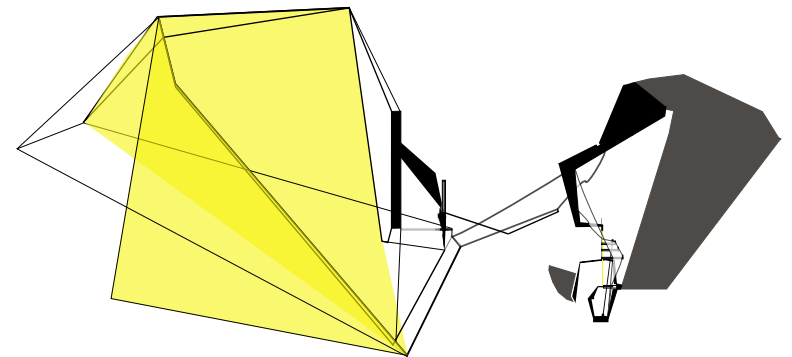
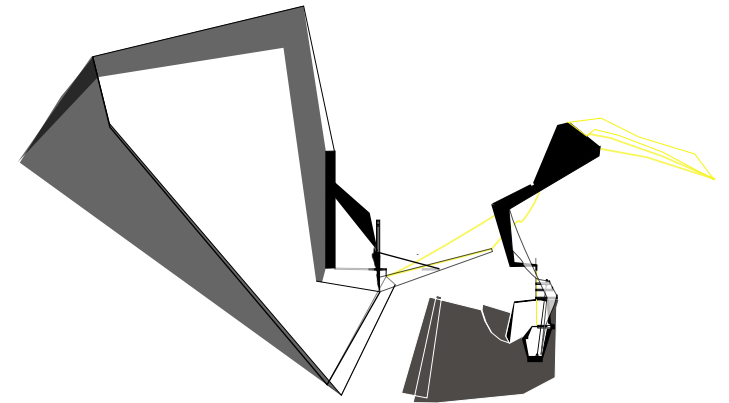
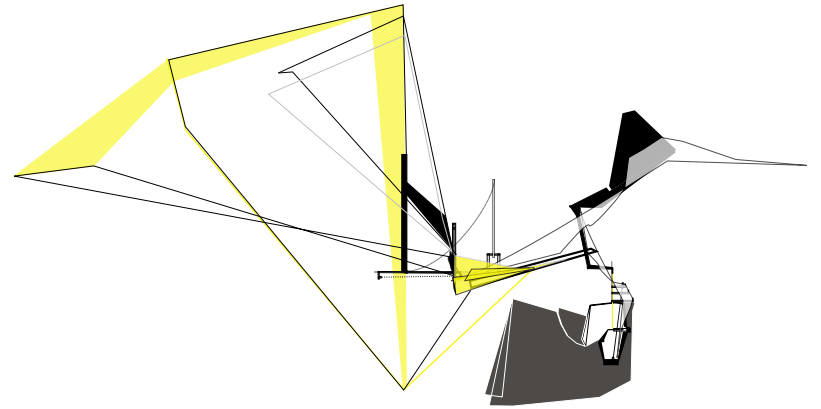

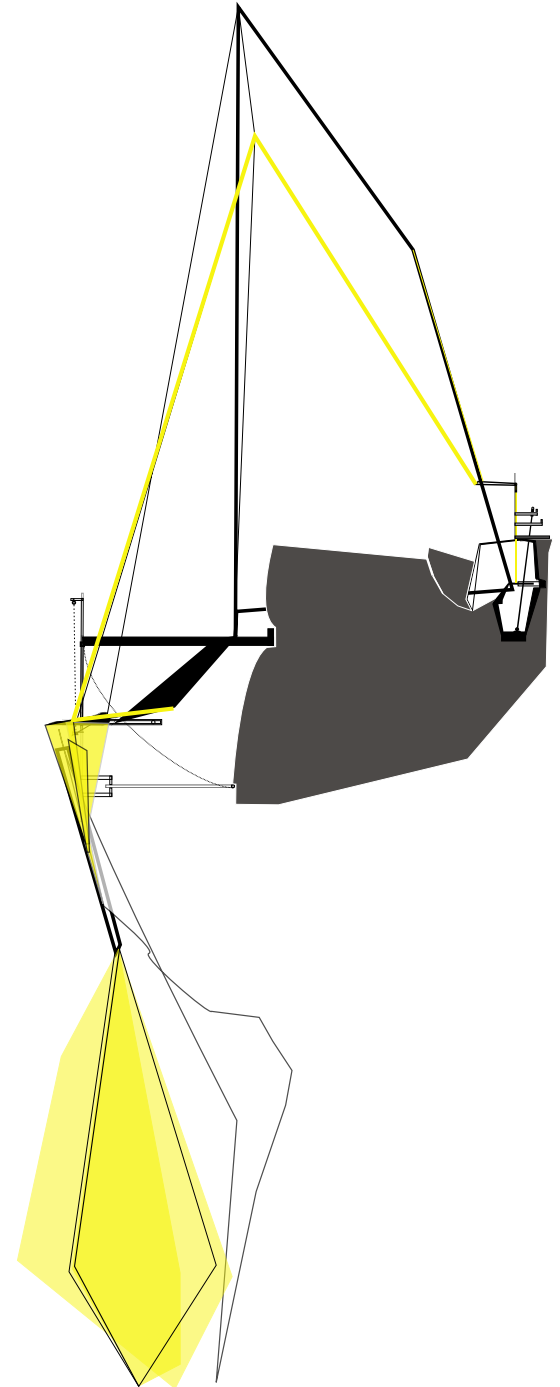
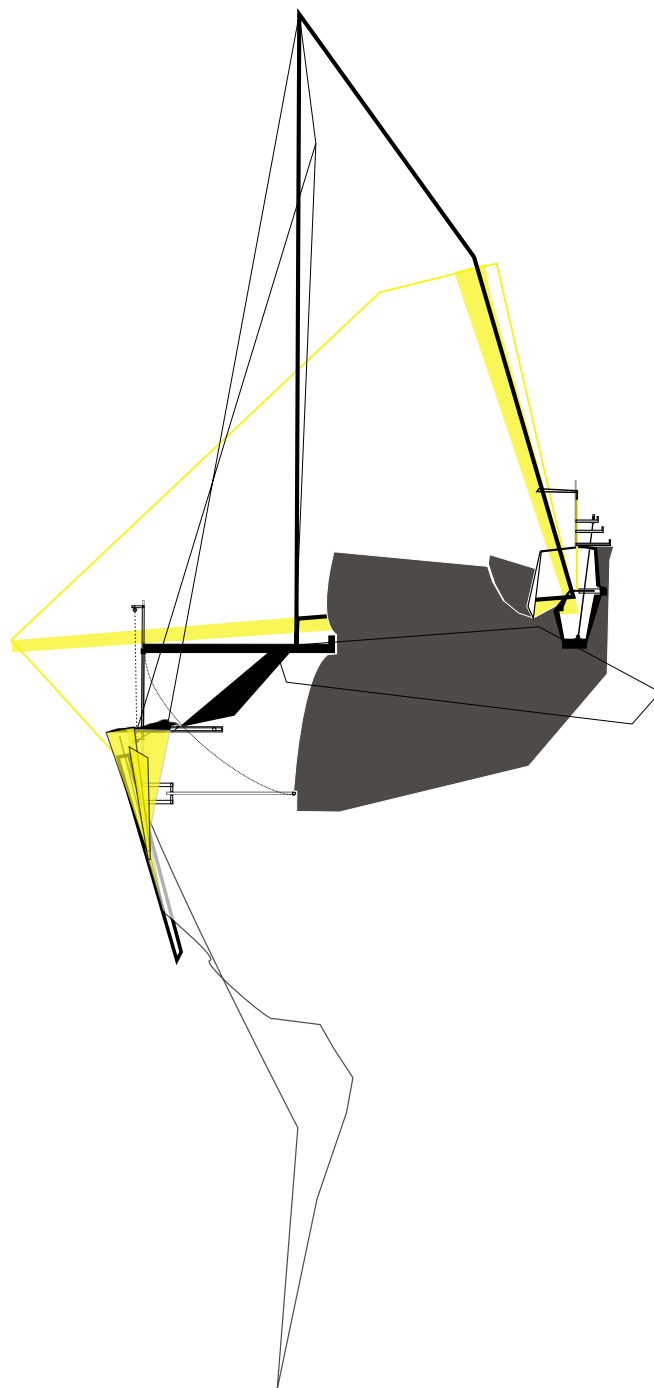

HYDRA 3 SOMMERSKOLE 2006



FORELÆSNING DEN 19. MARTS 2006 KL. 19.00 - HOTEL THEANO



HENRIK OXVIG
KUNSTHISTORIKER. DANMARK
efter
Le Mystère Picasso

Klik for at høre

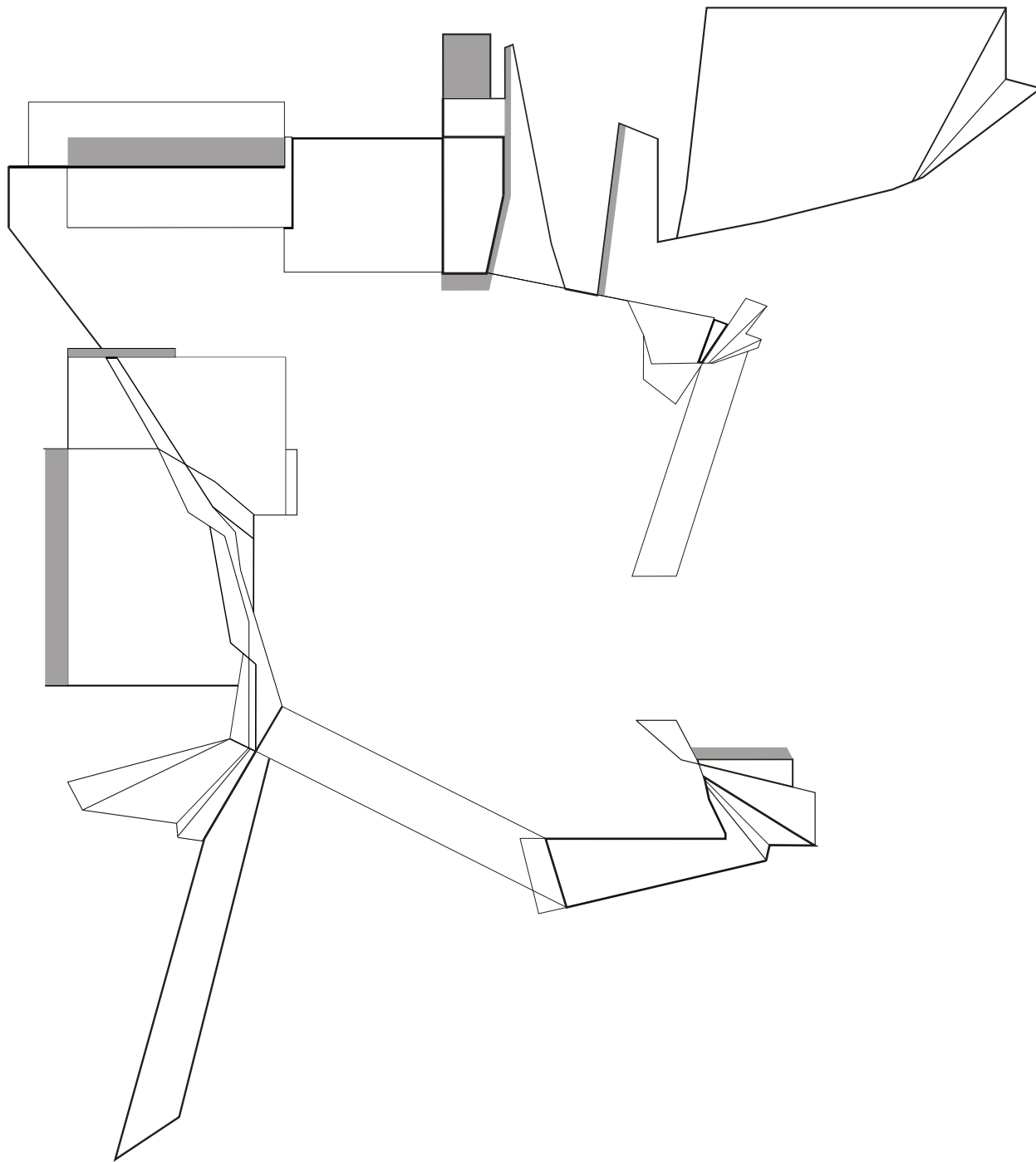

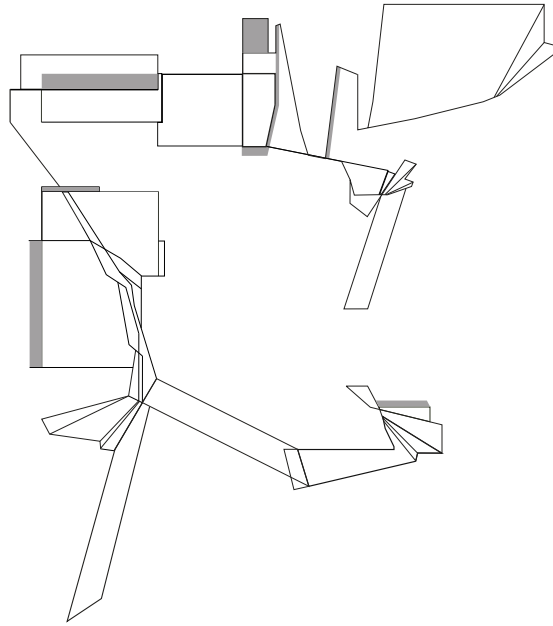

det viklede_stregen

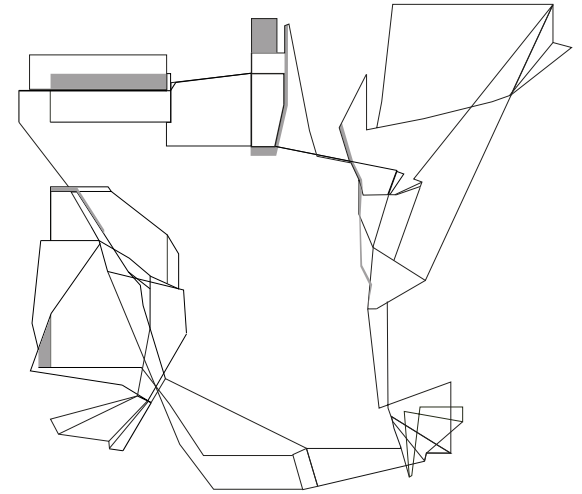

det foldede_streg&flade

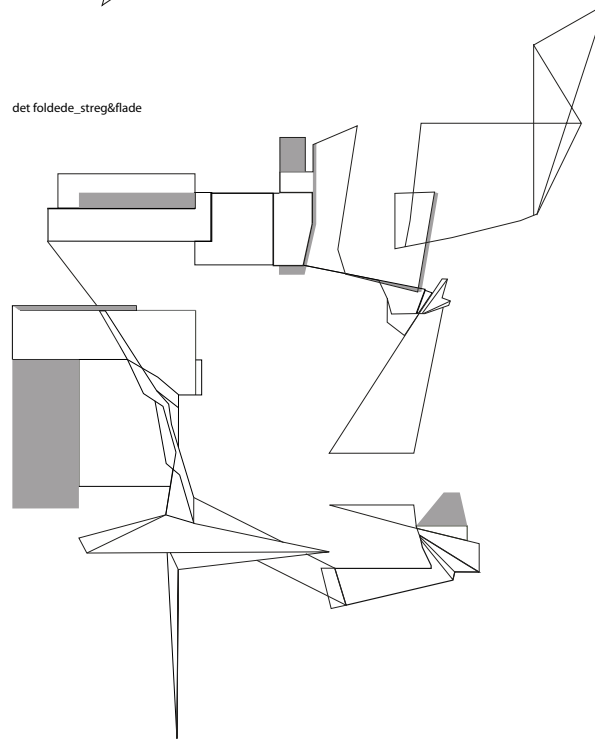

det forskudte_fladen

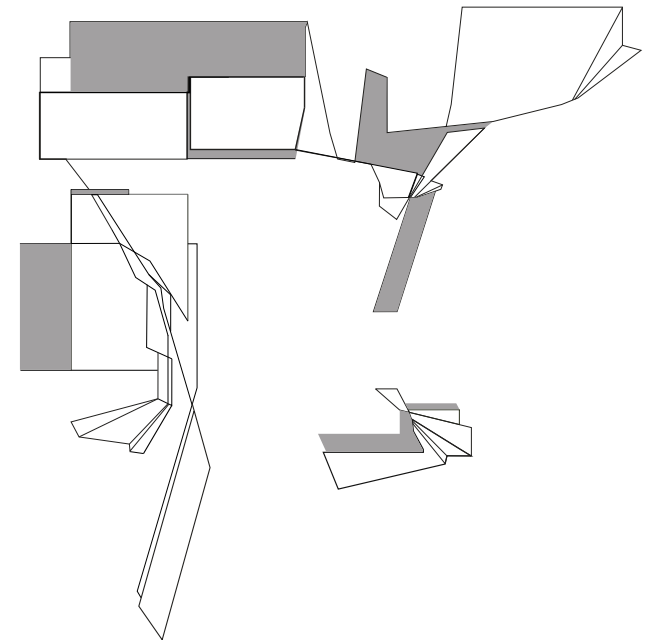

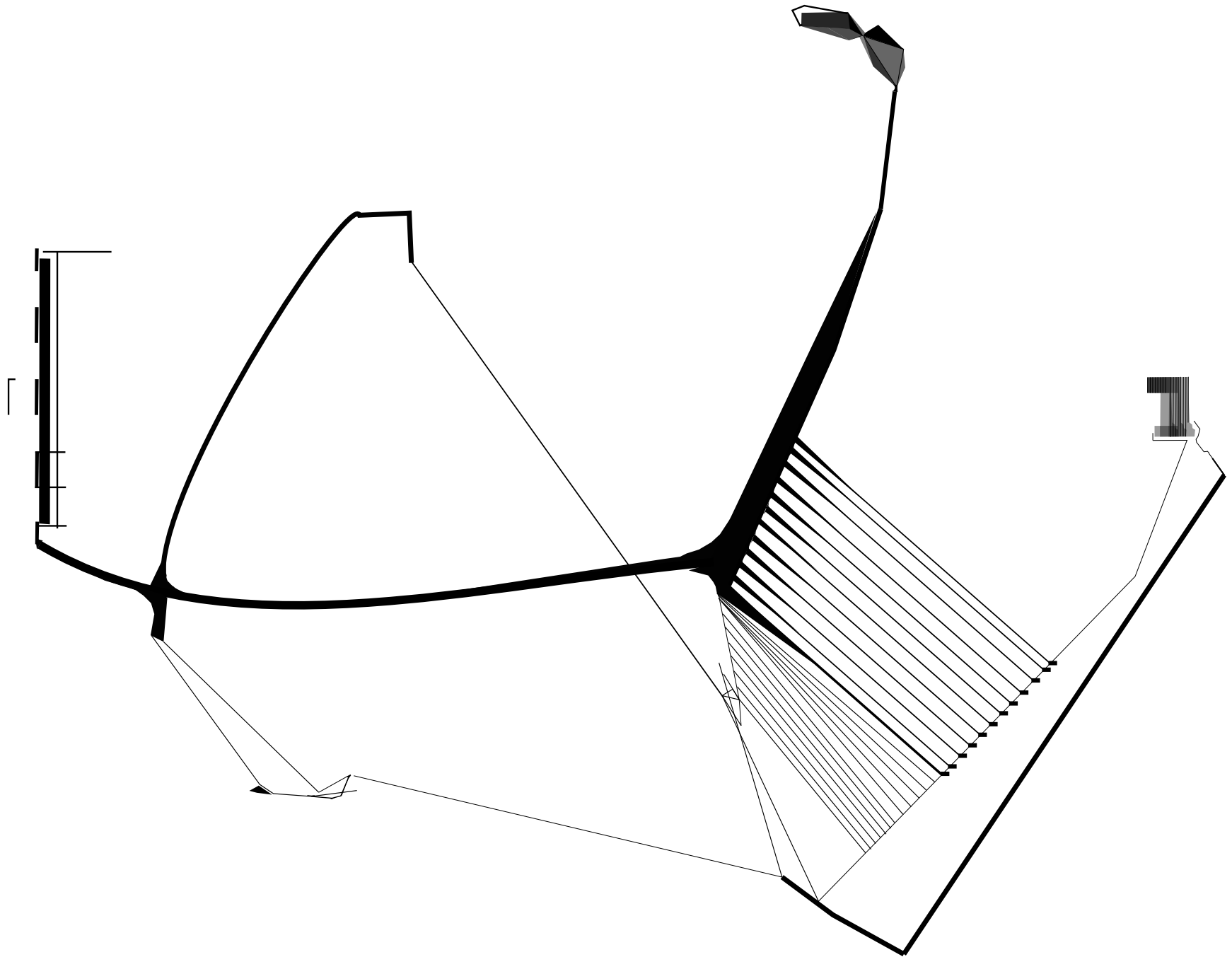

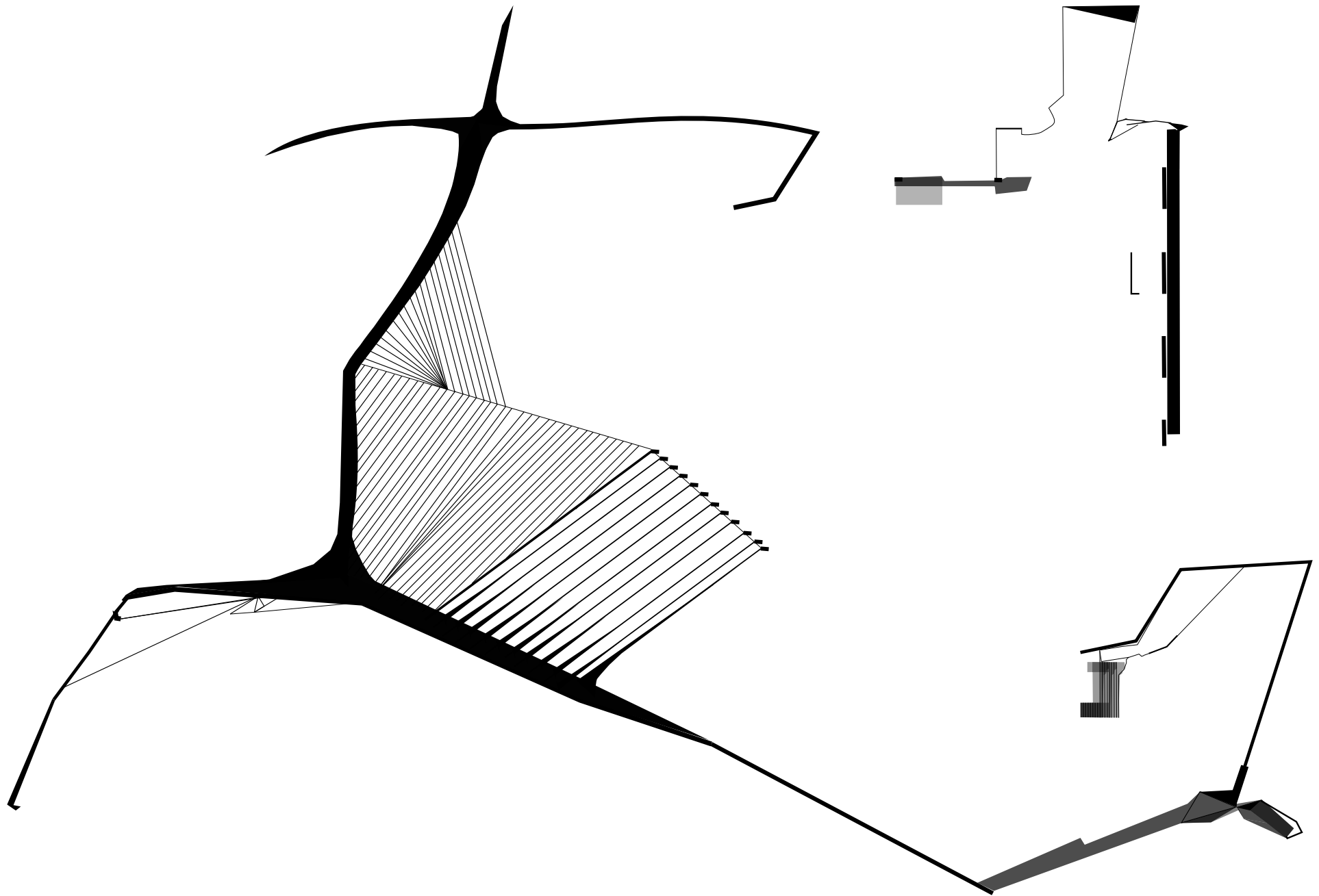

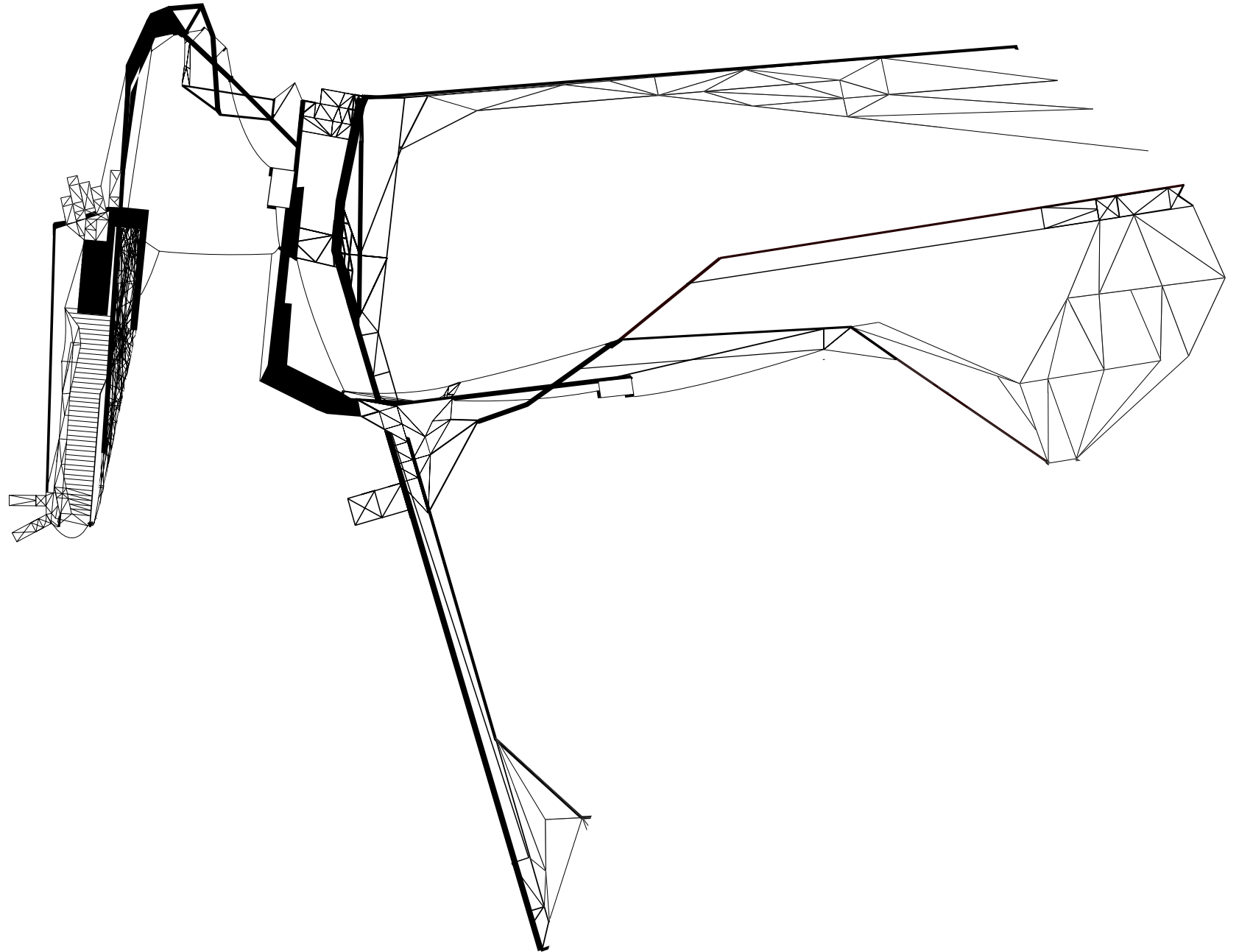

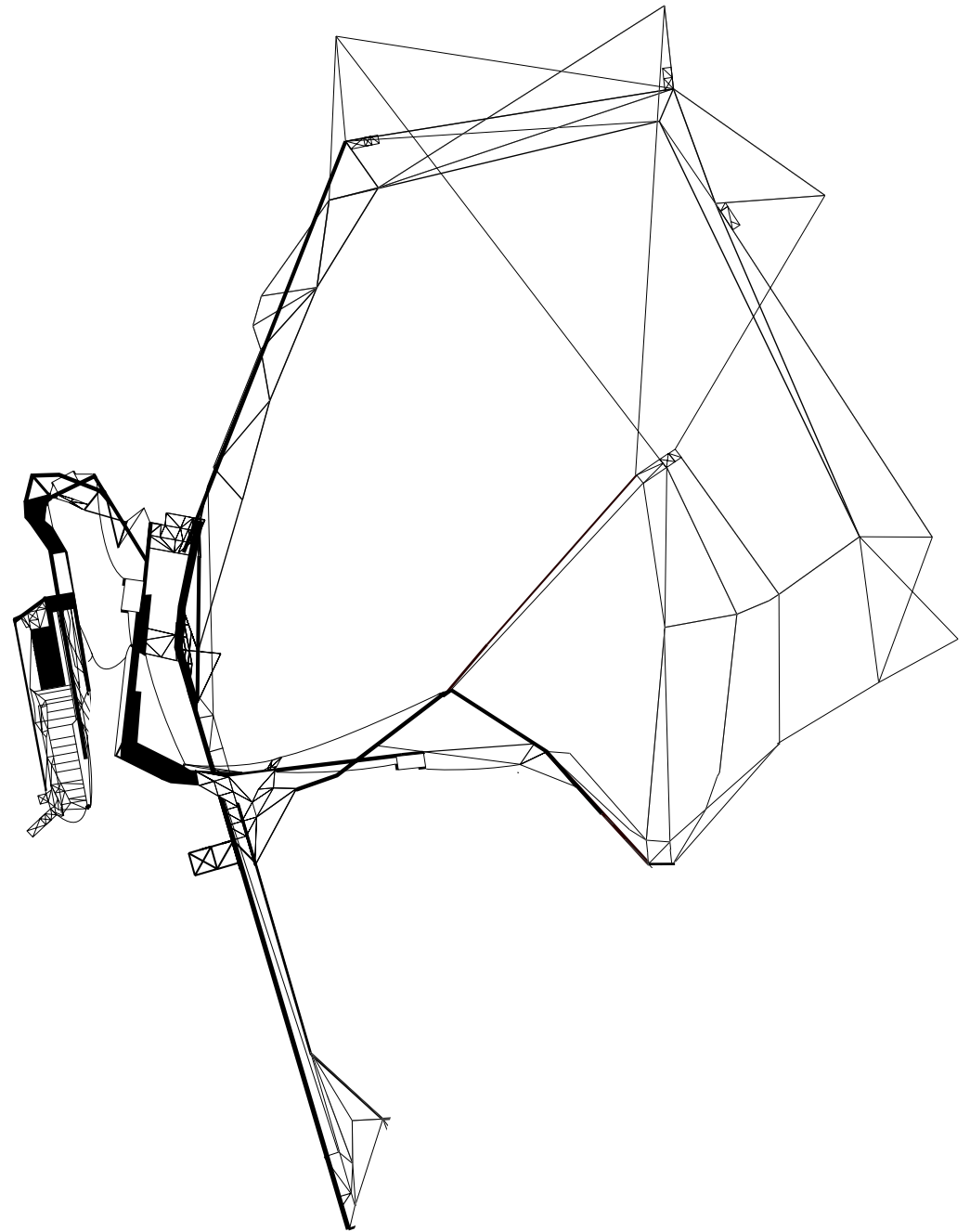

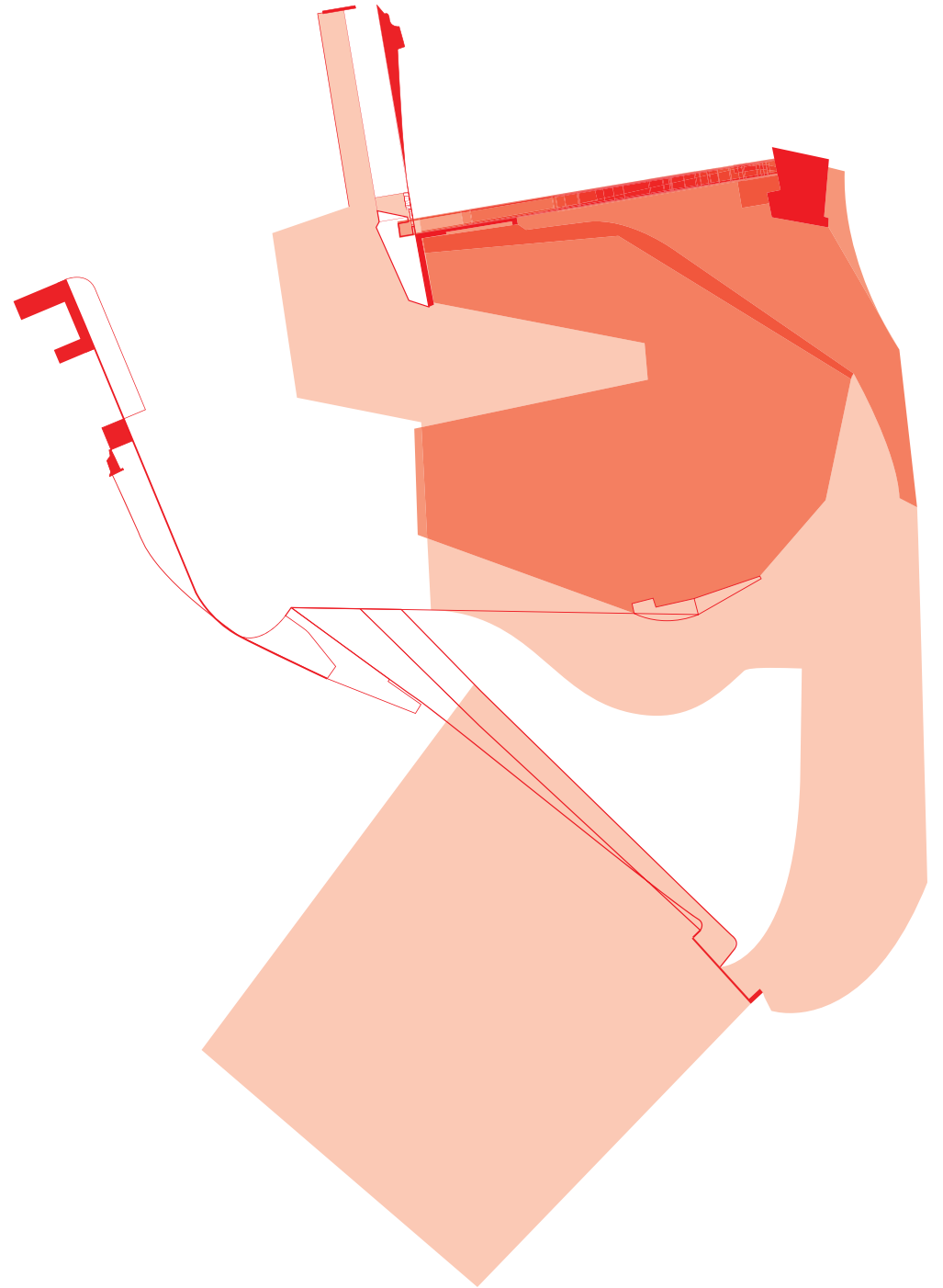



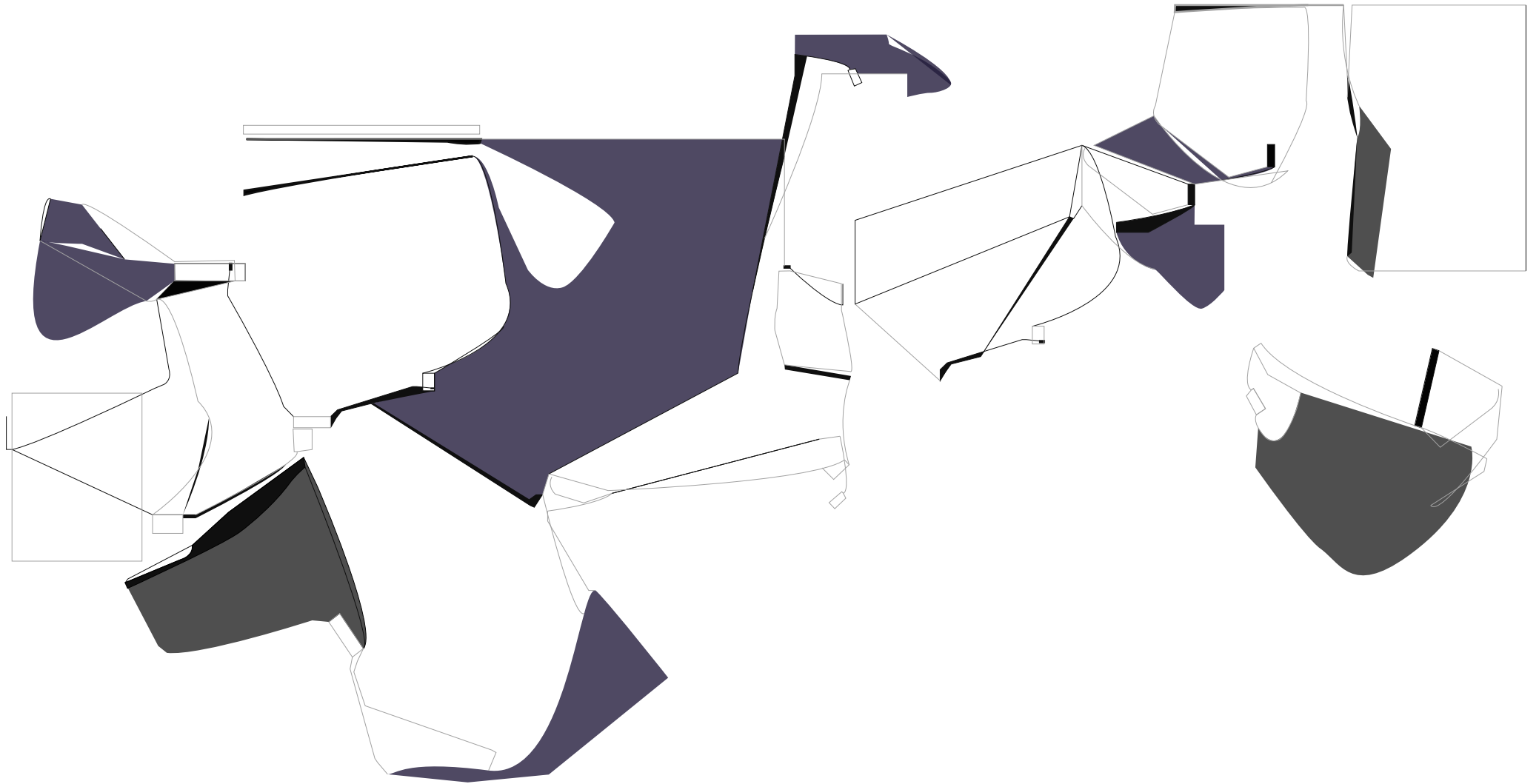

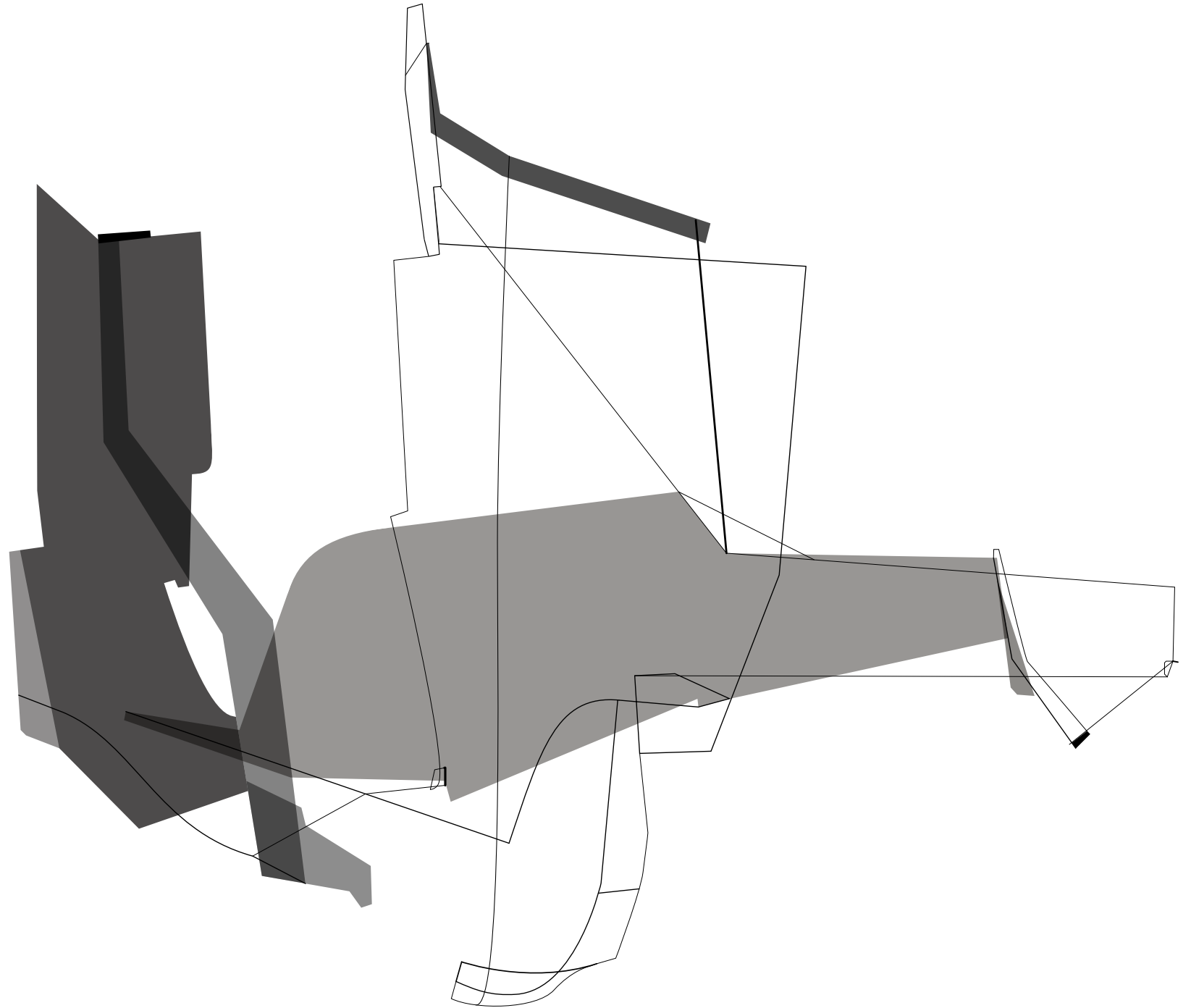

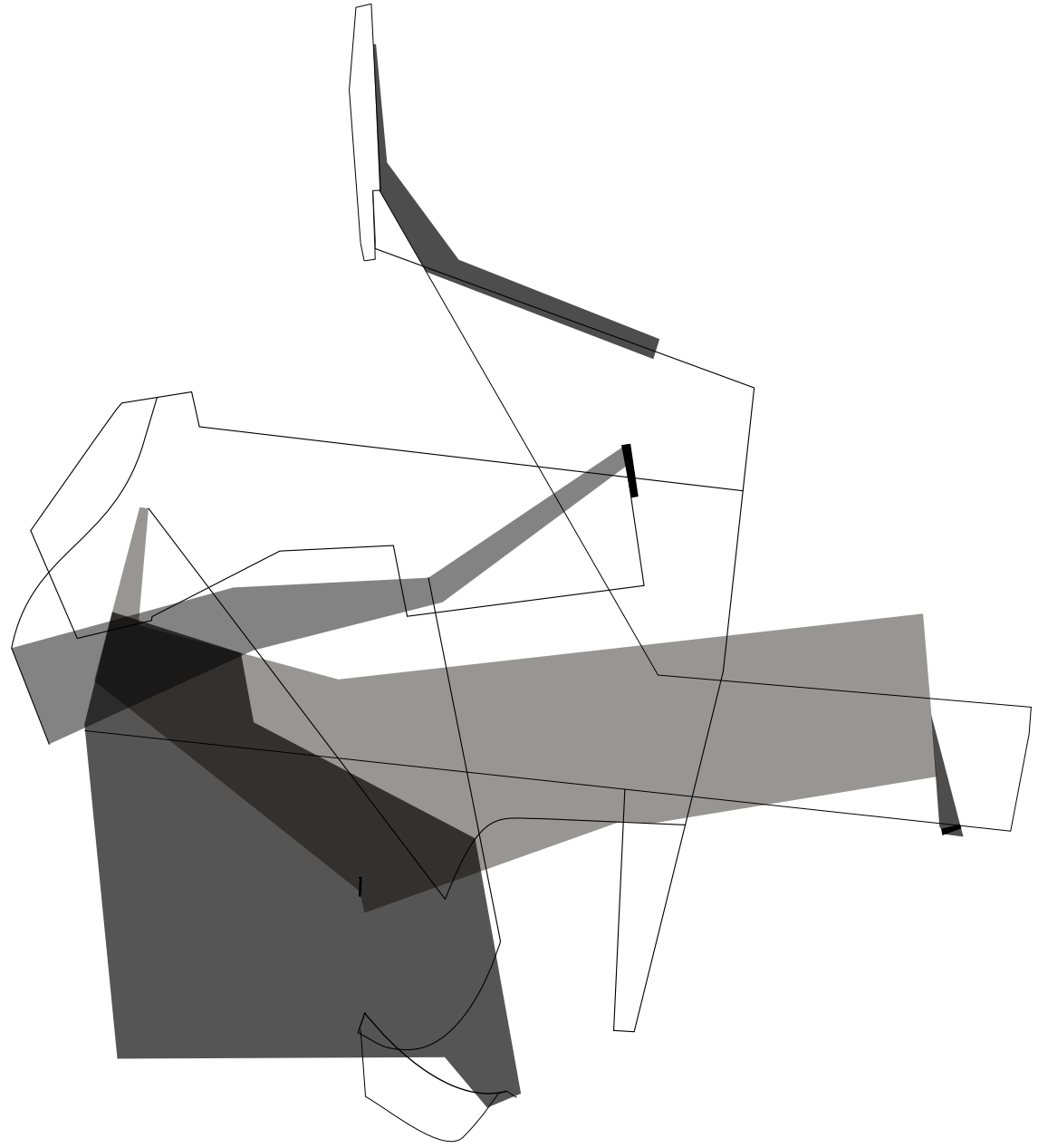
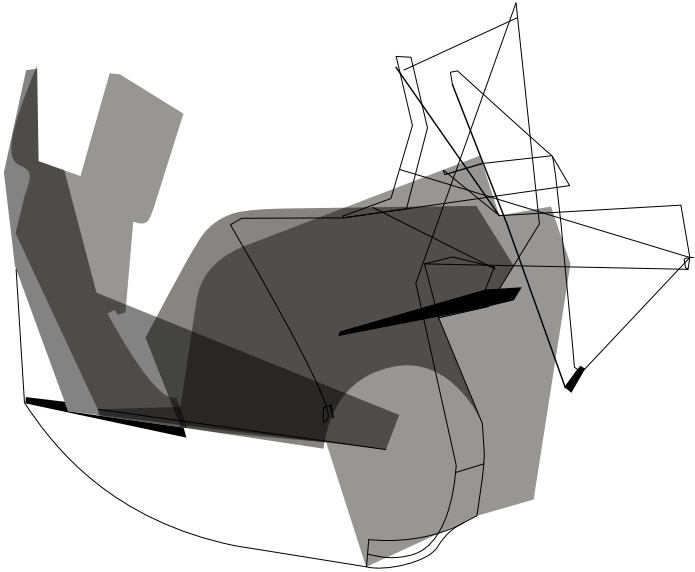
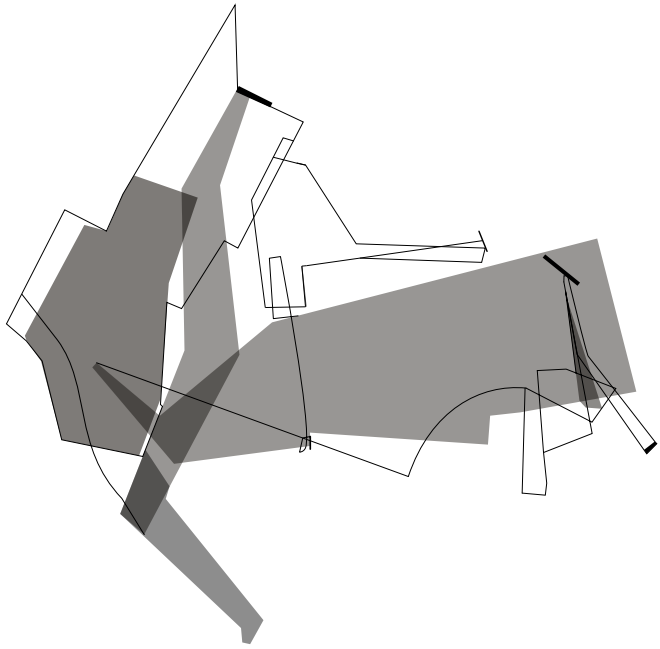

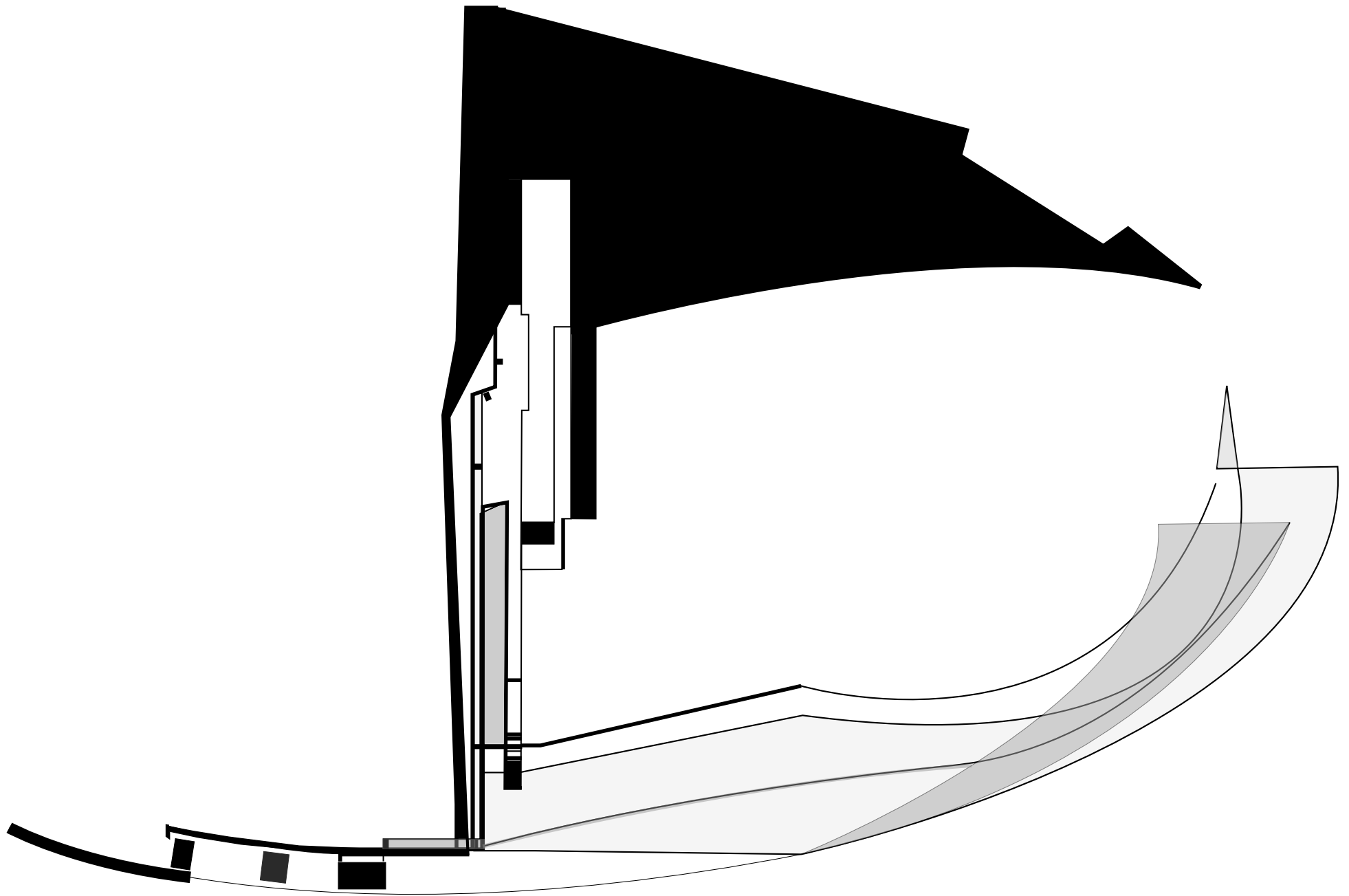

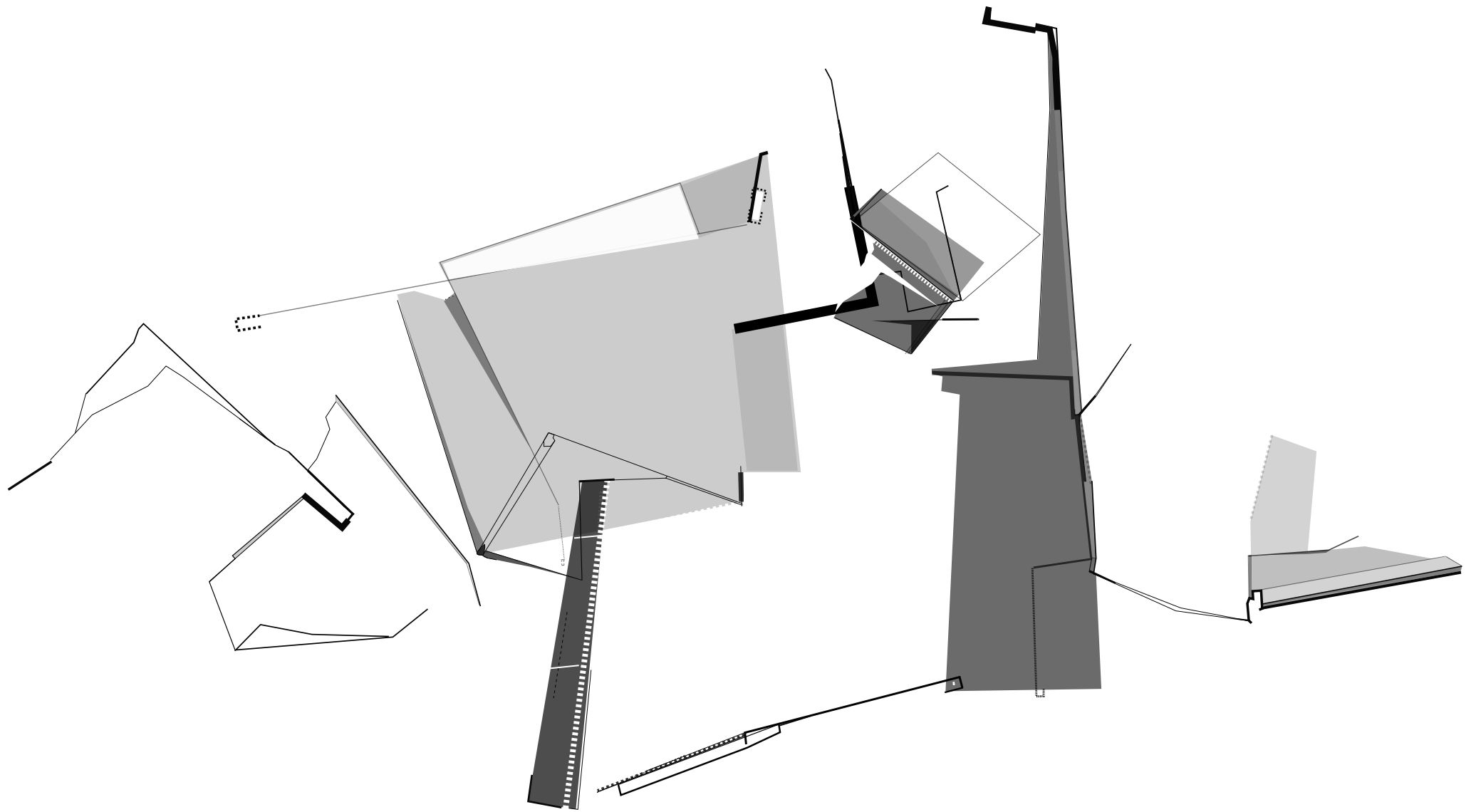

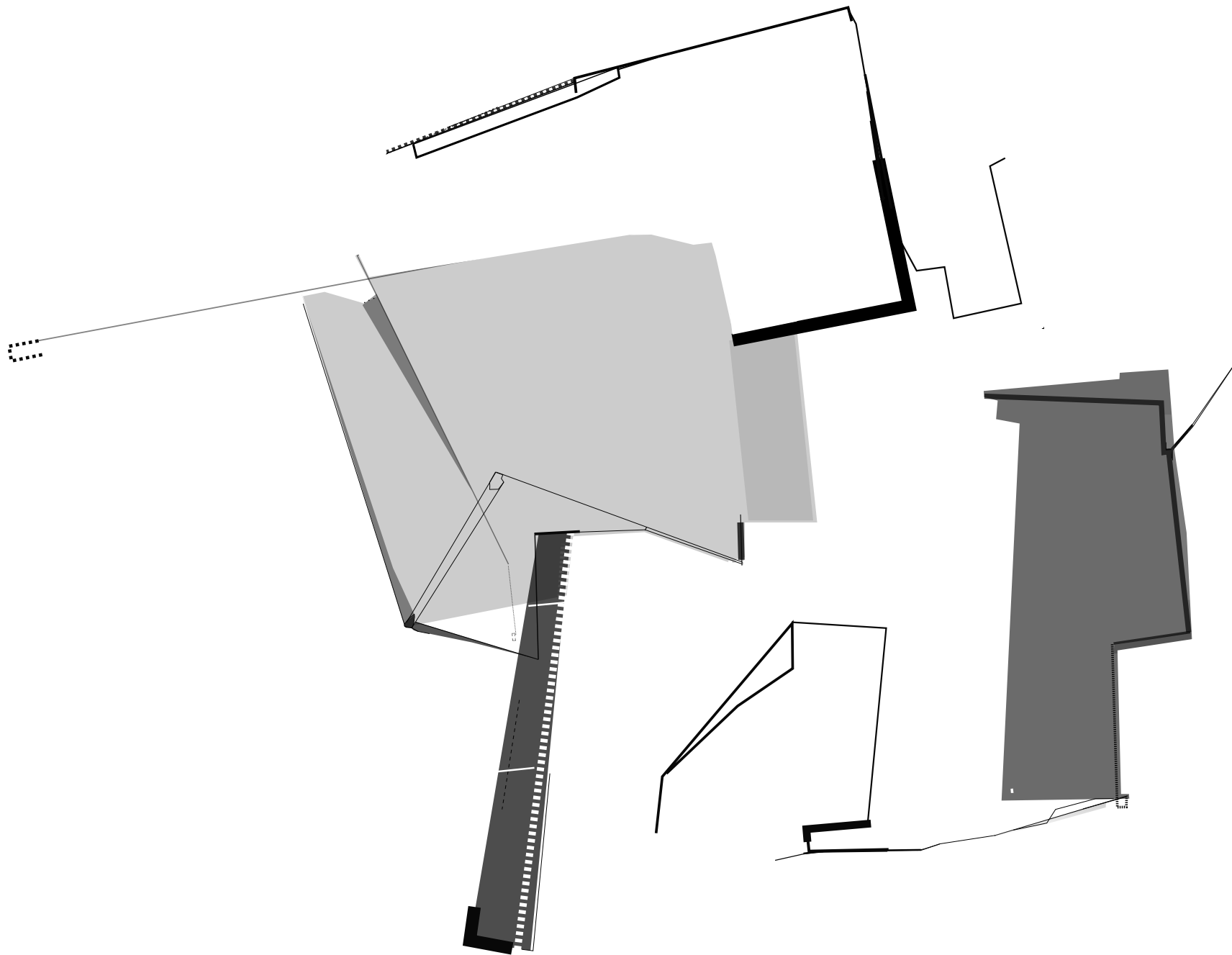

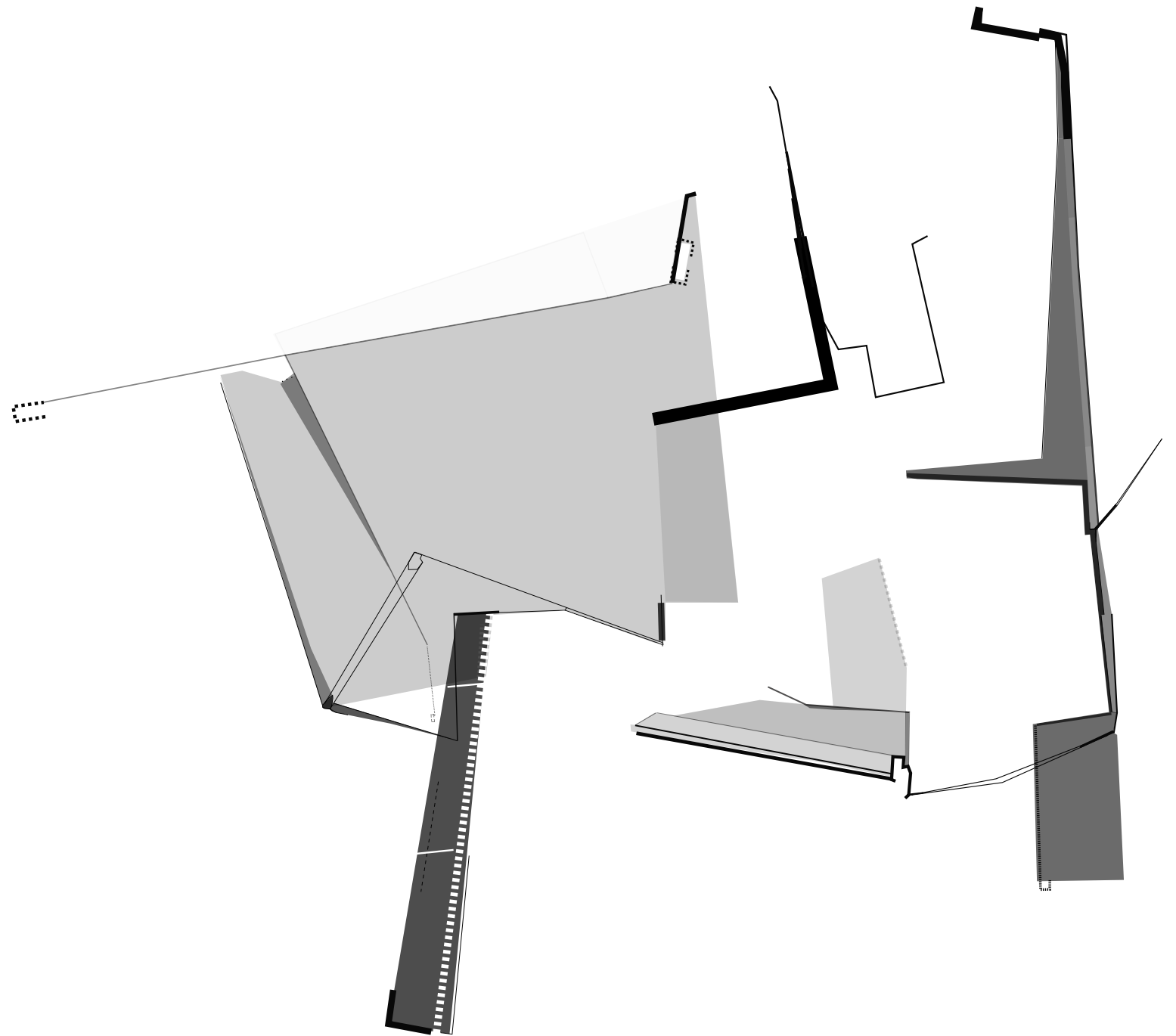

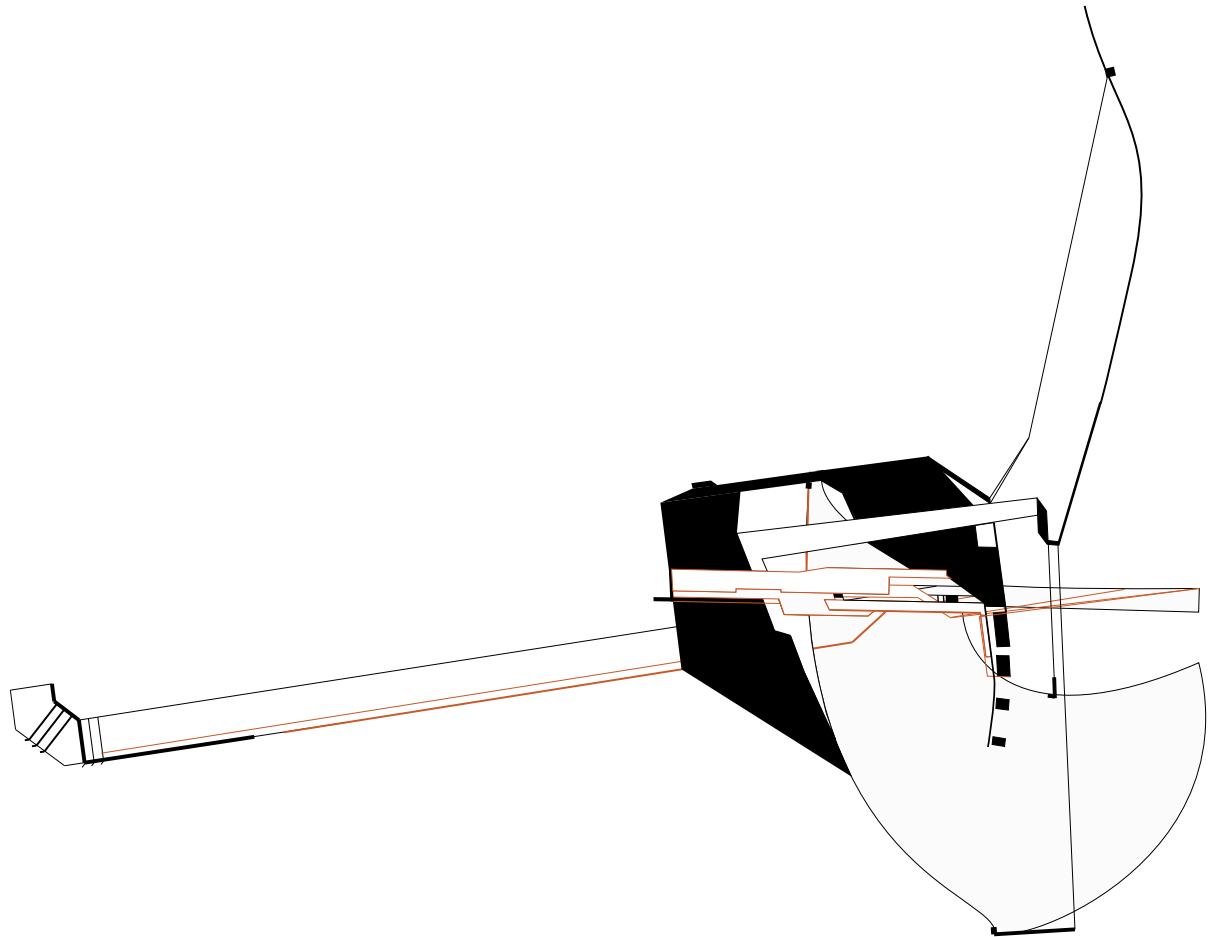
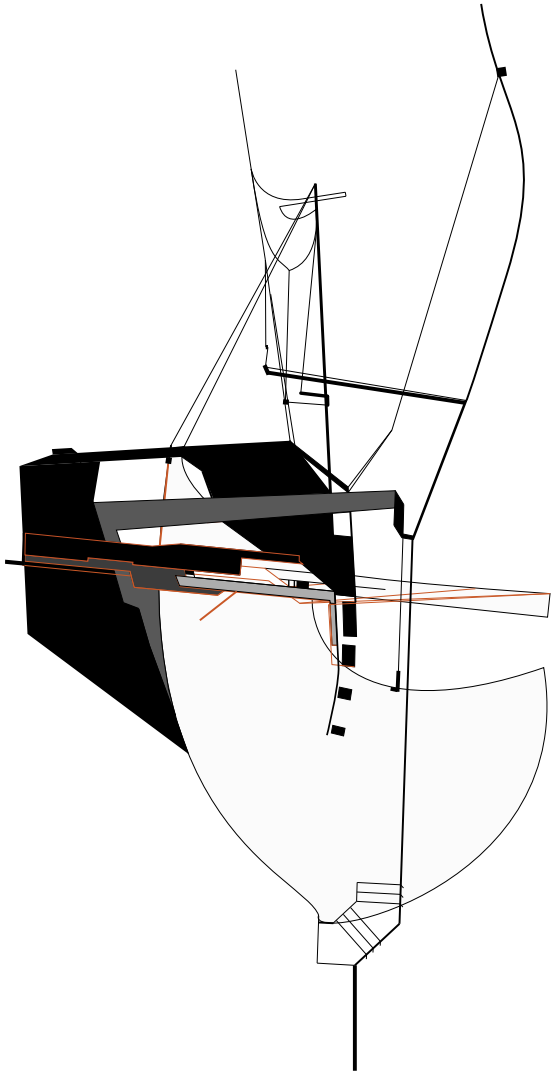

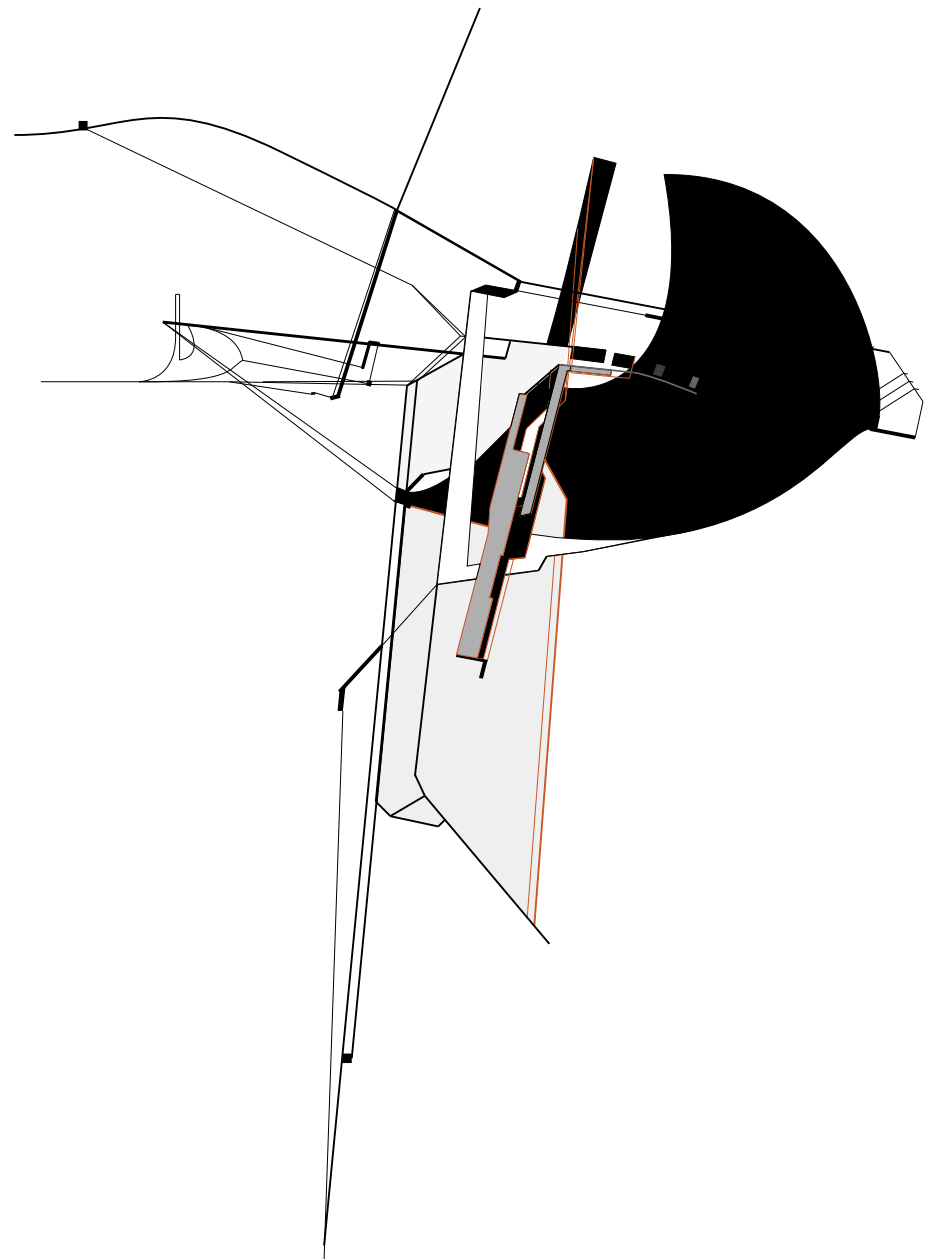
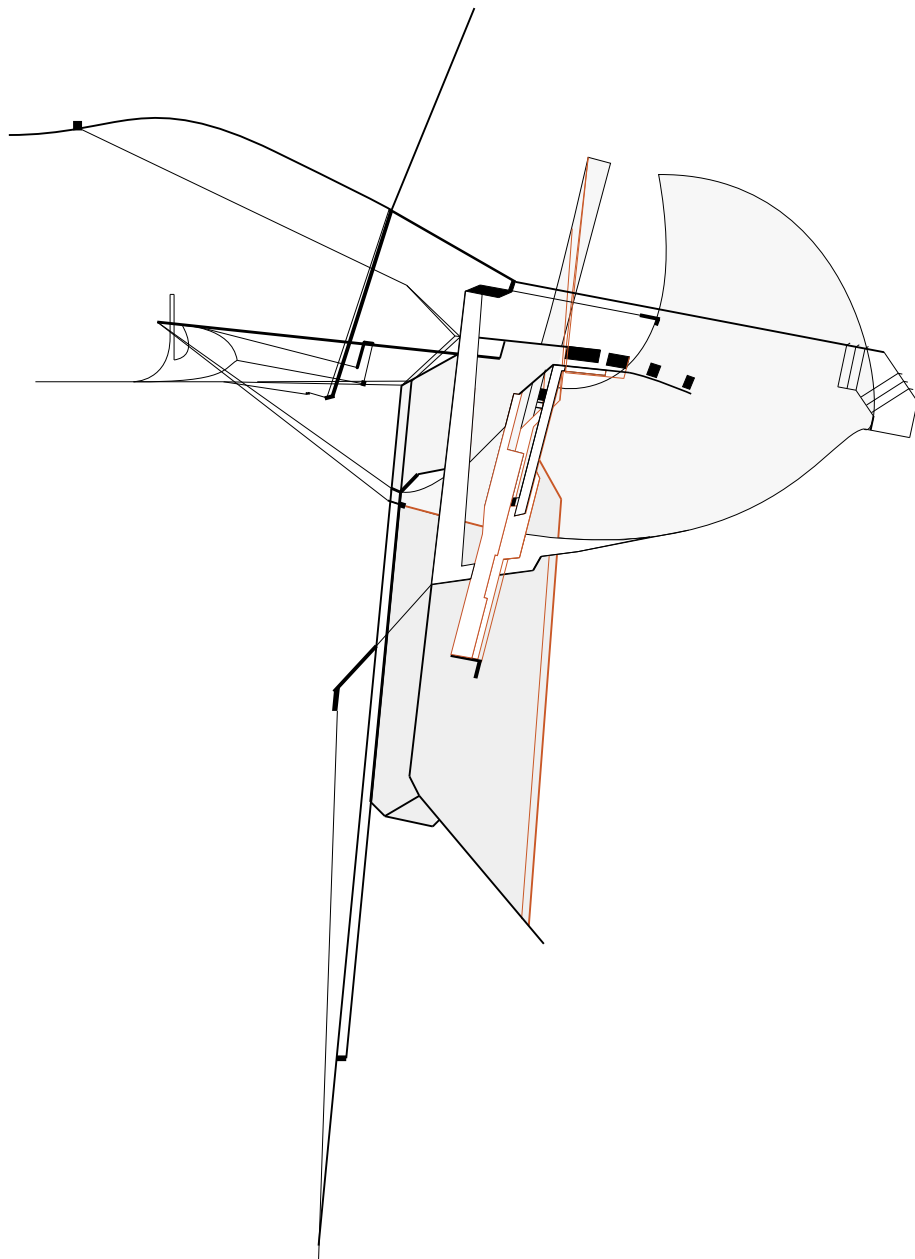

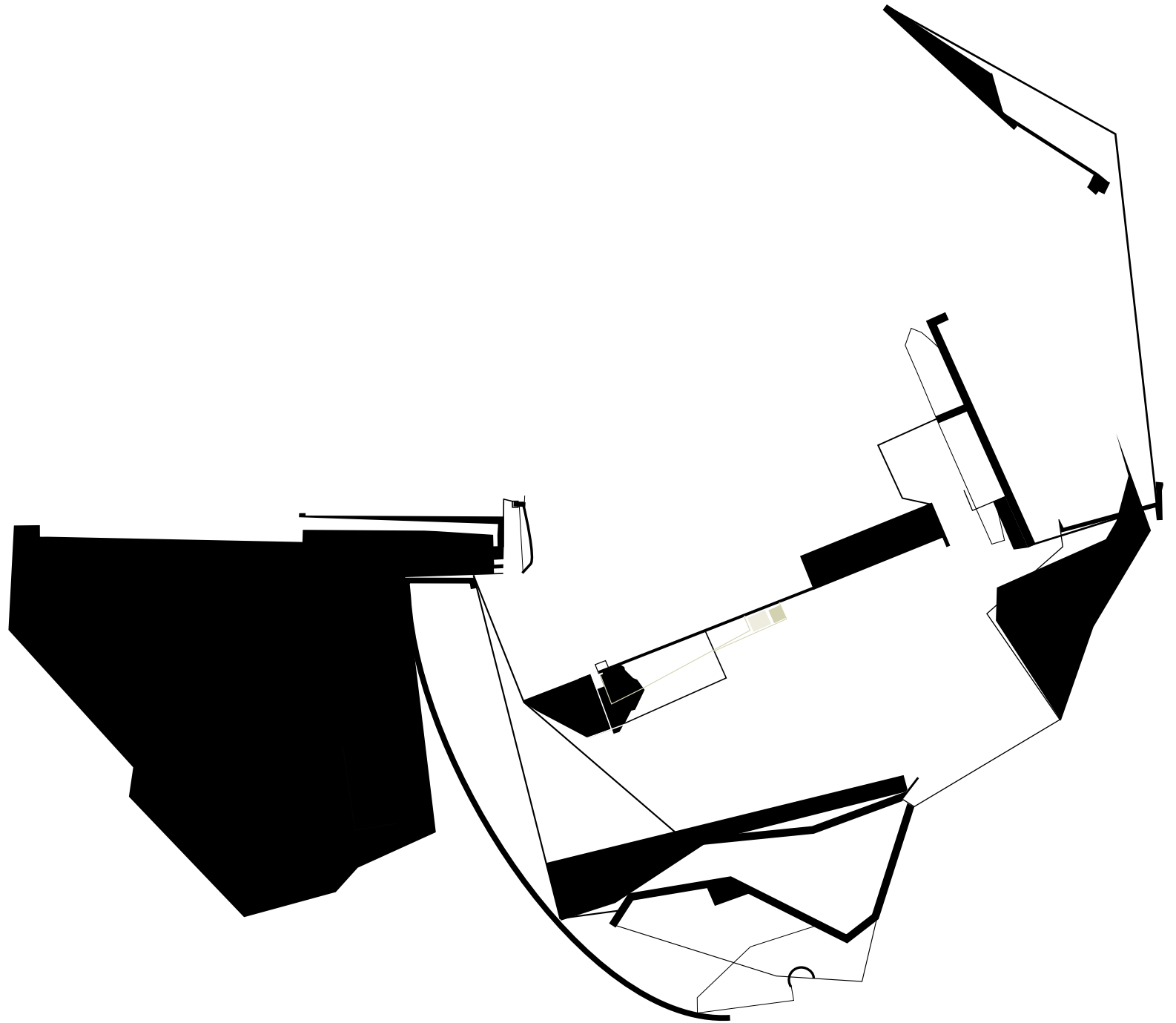

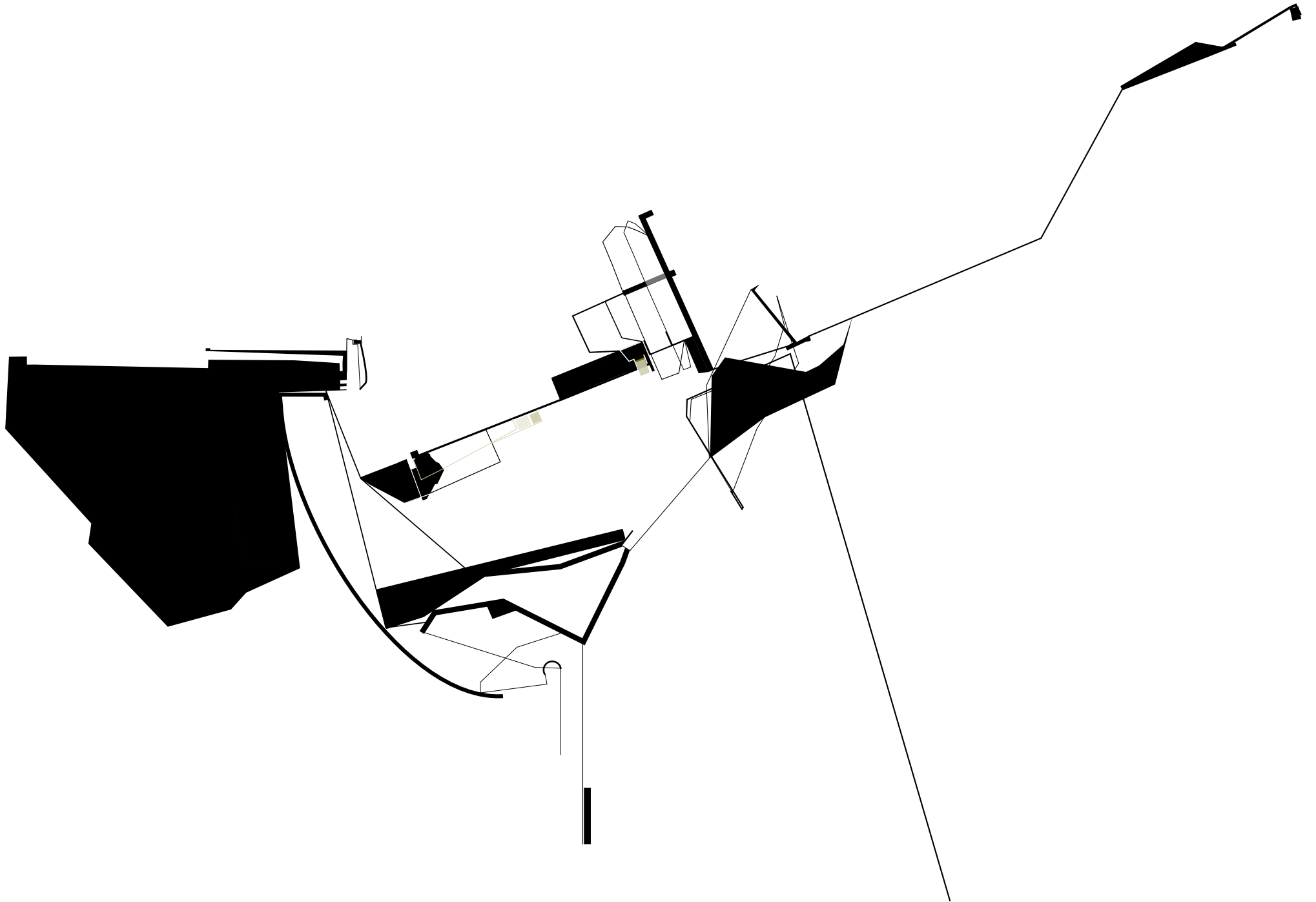

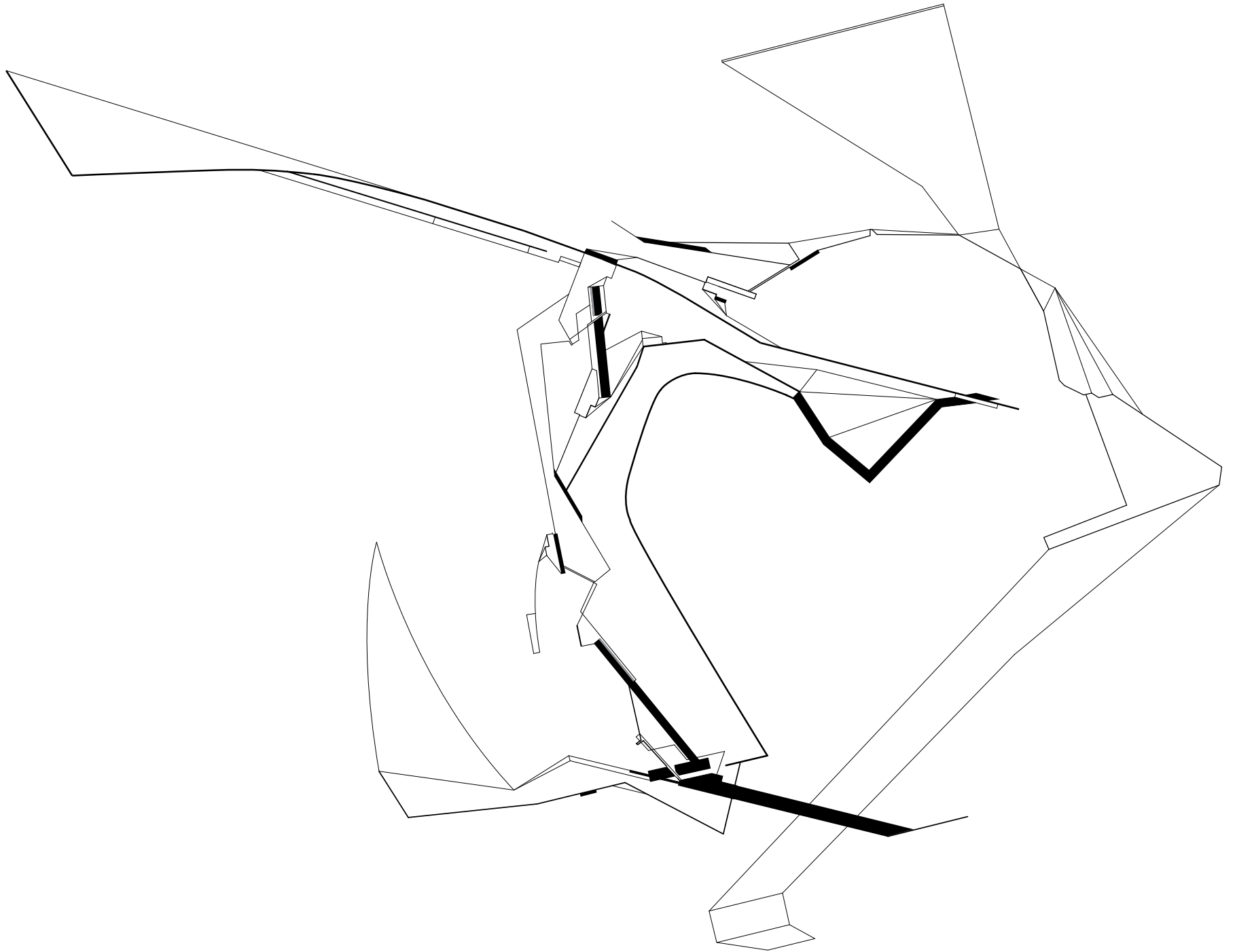

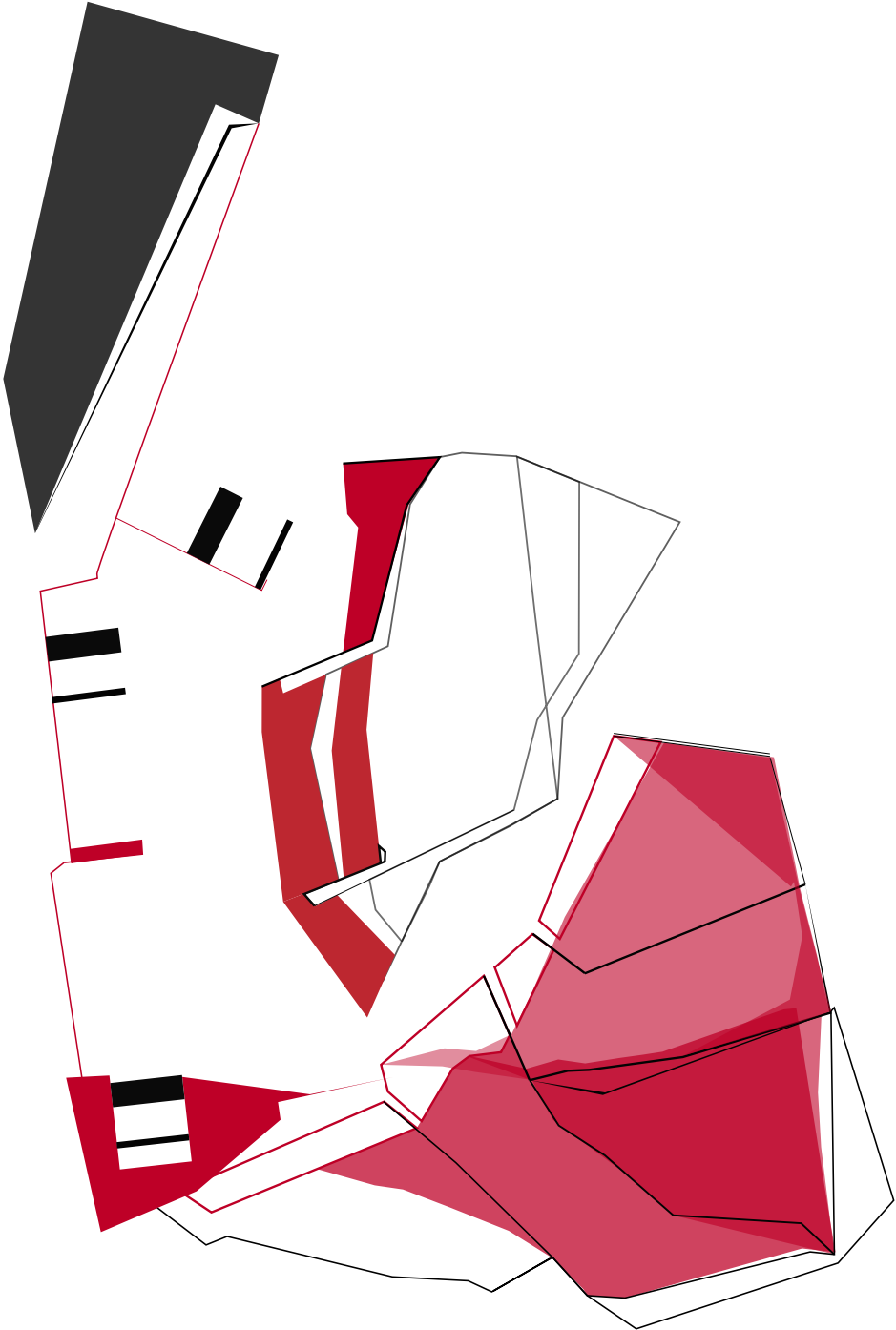

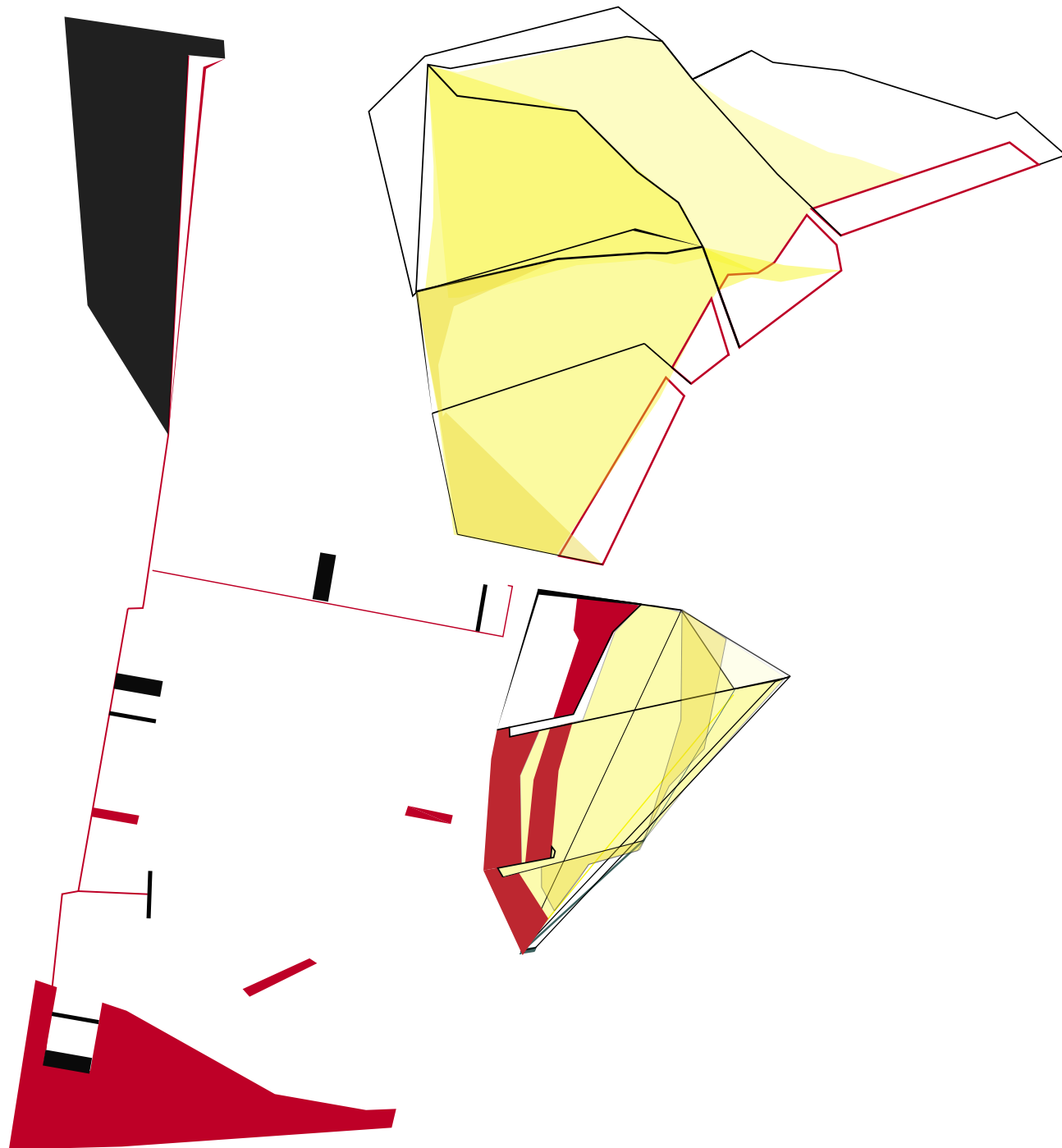

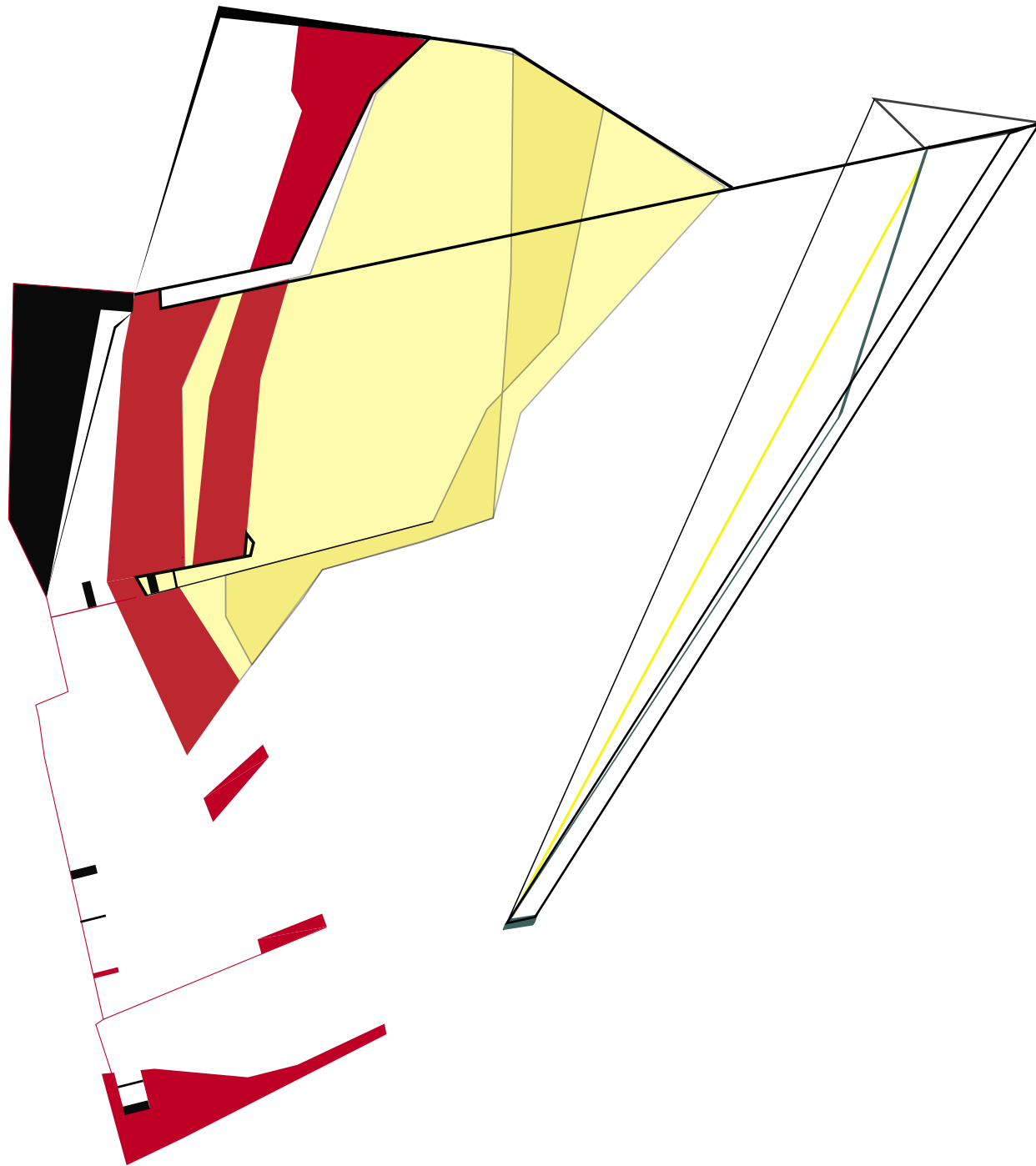

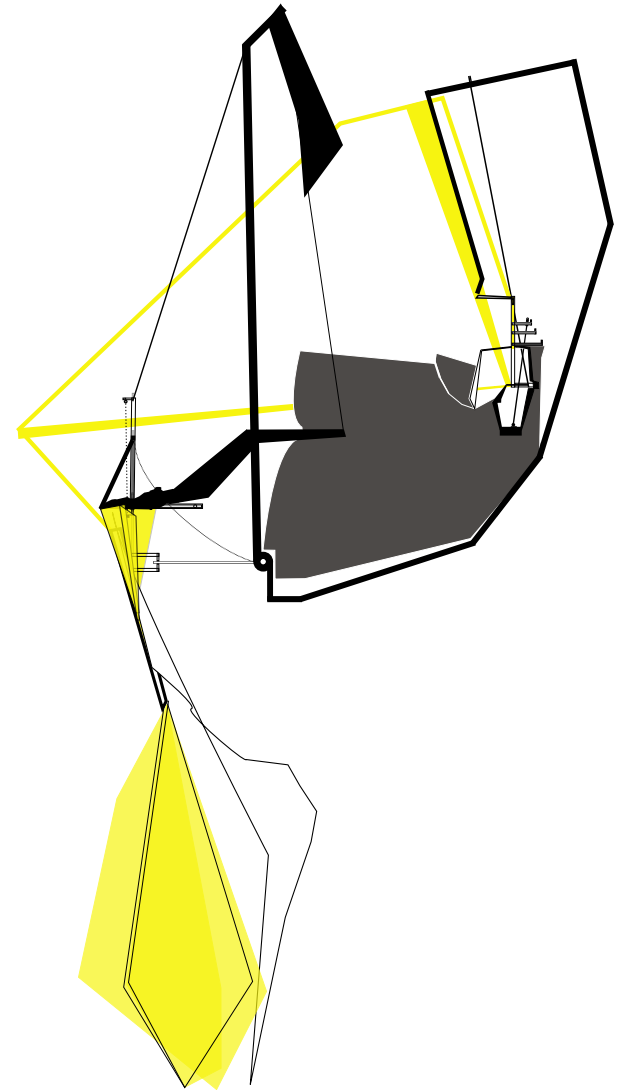
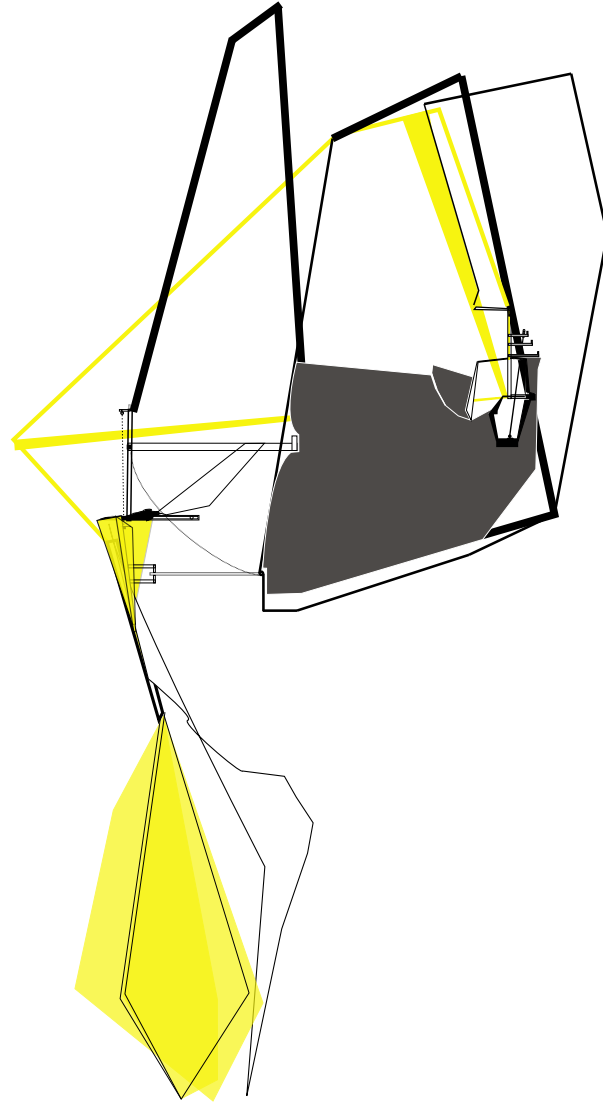
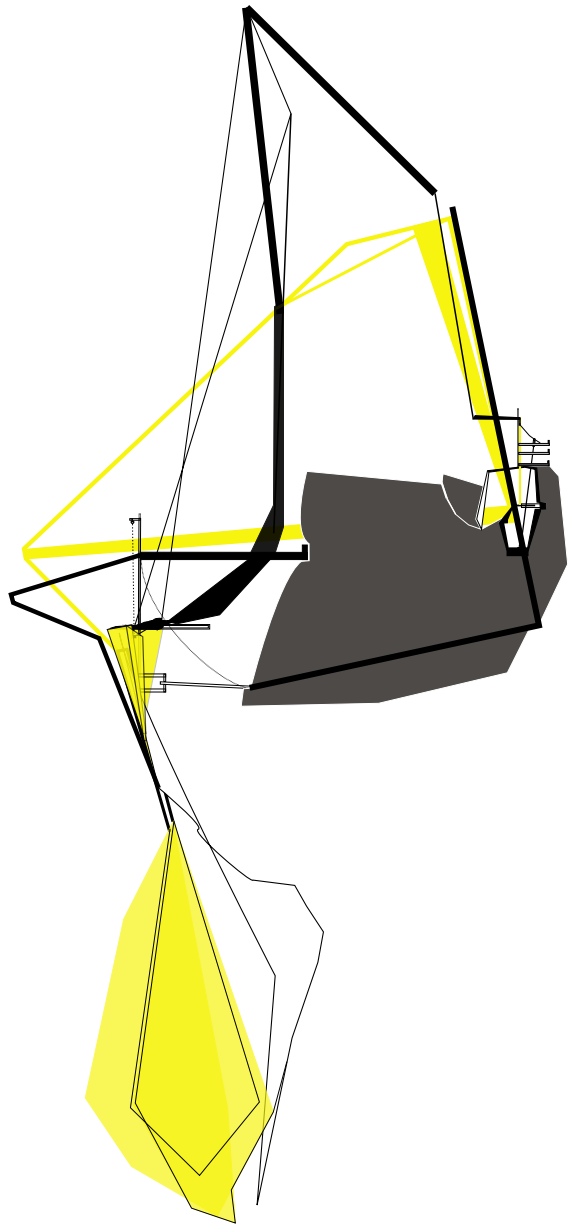

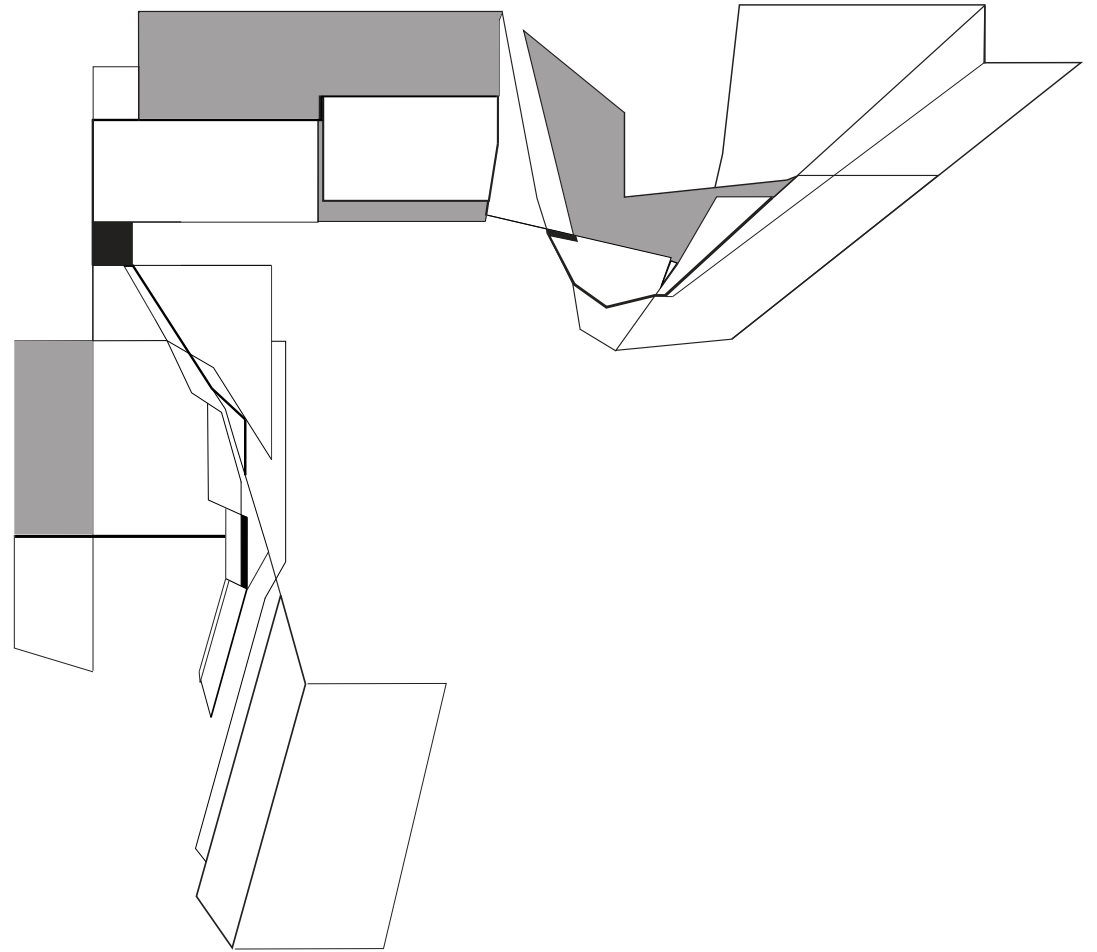
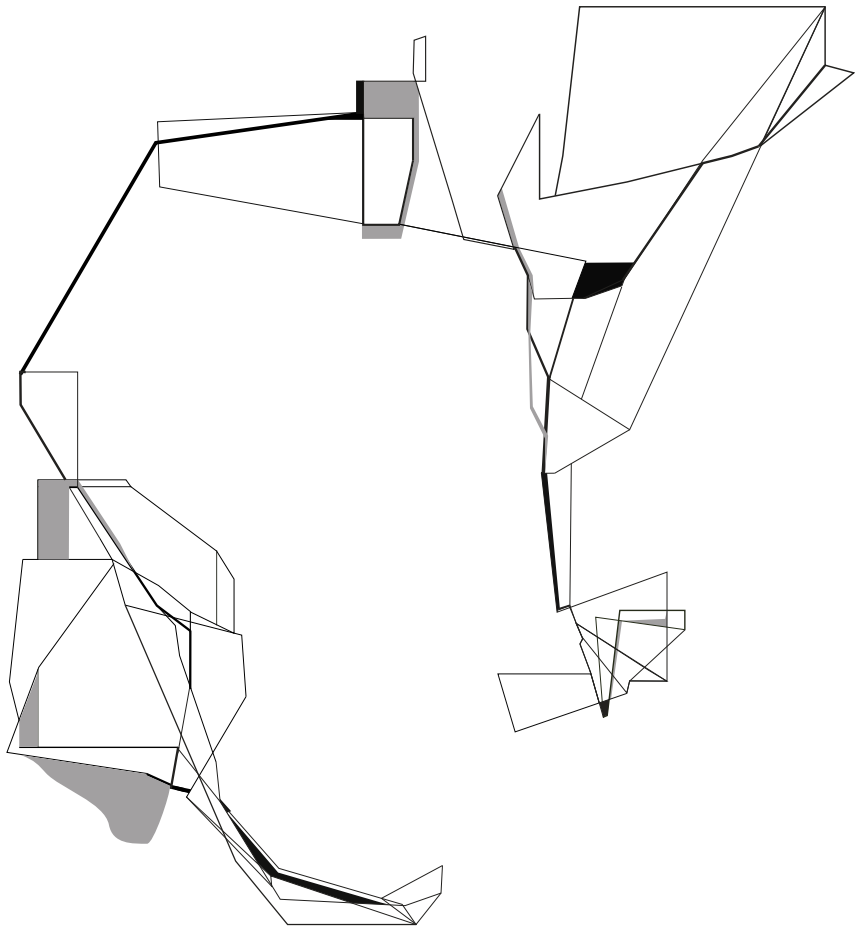

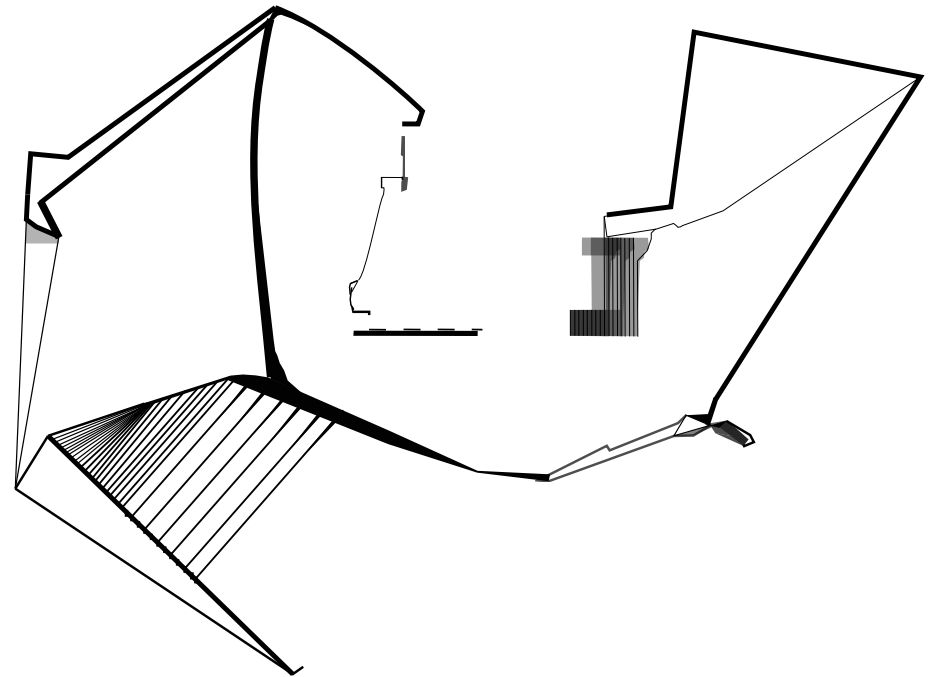
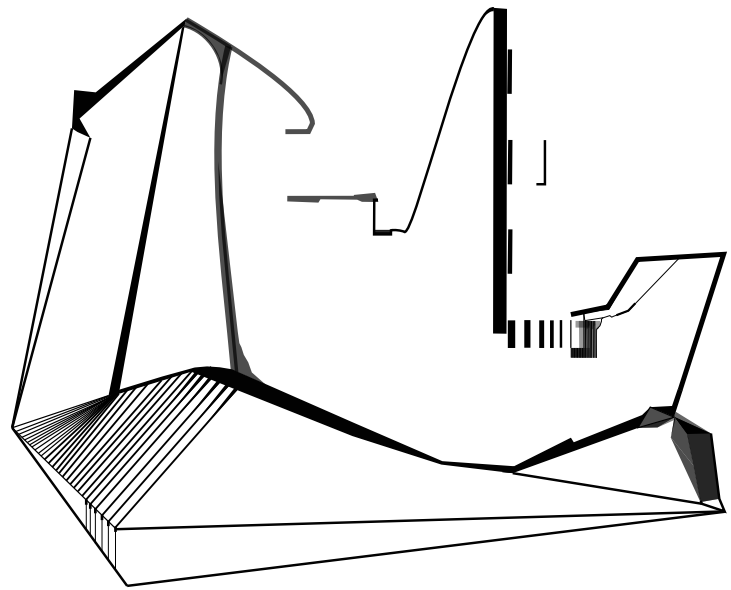

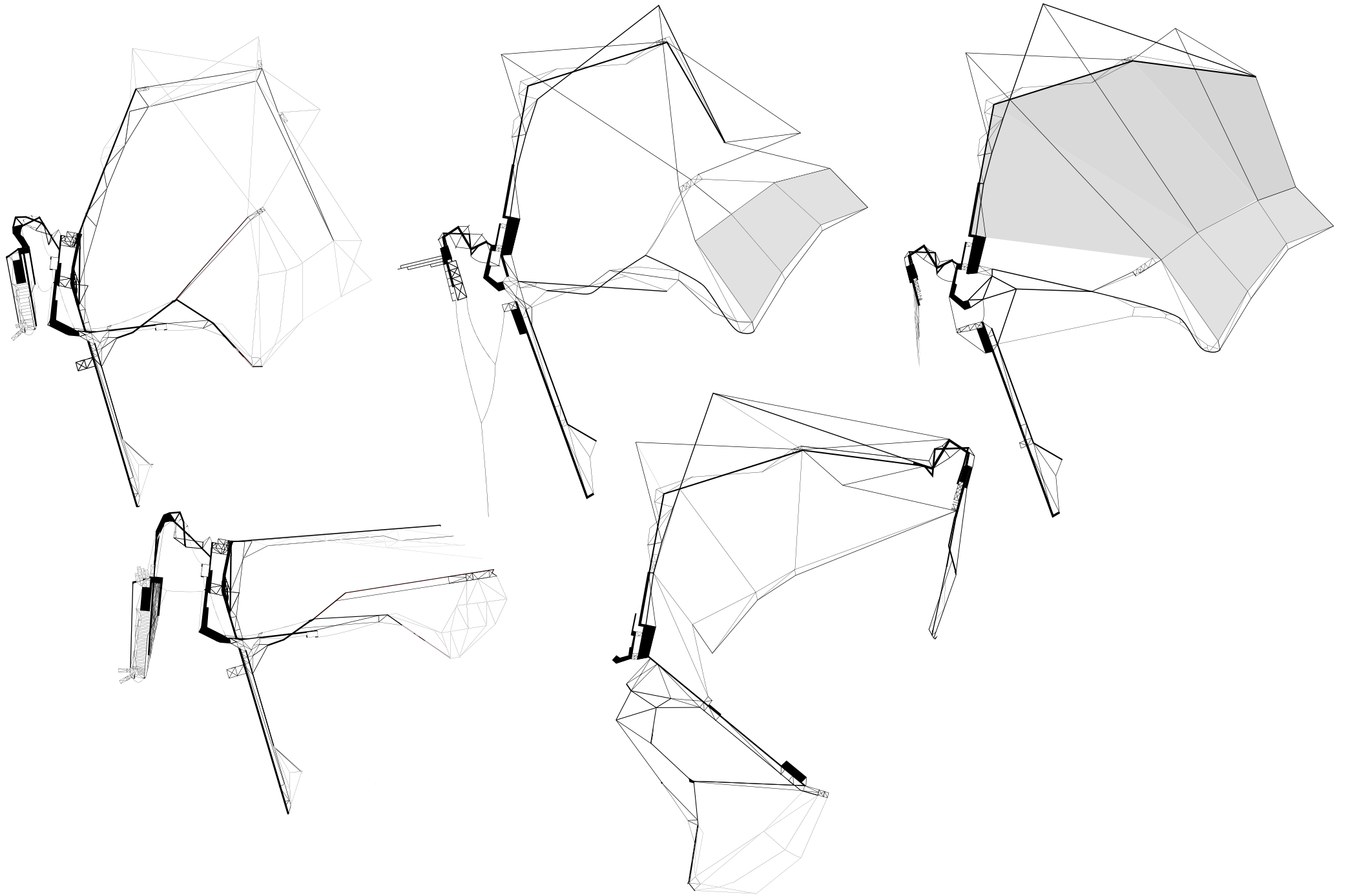

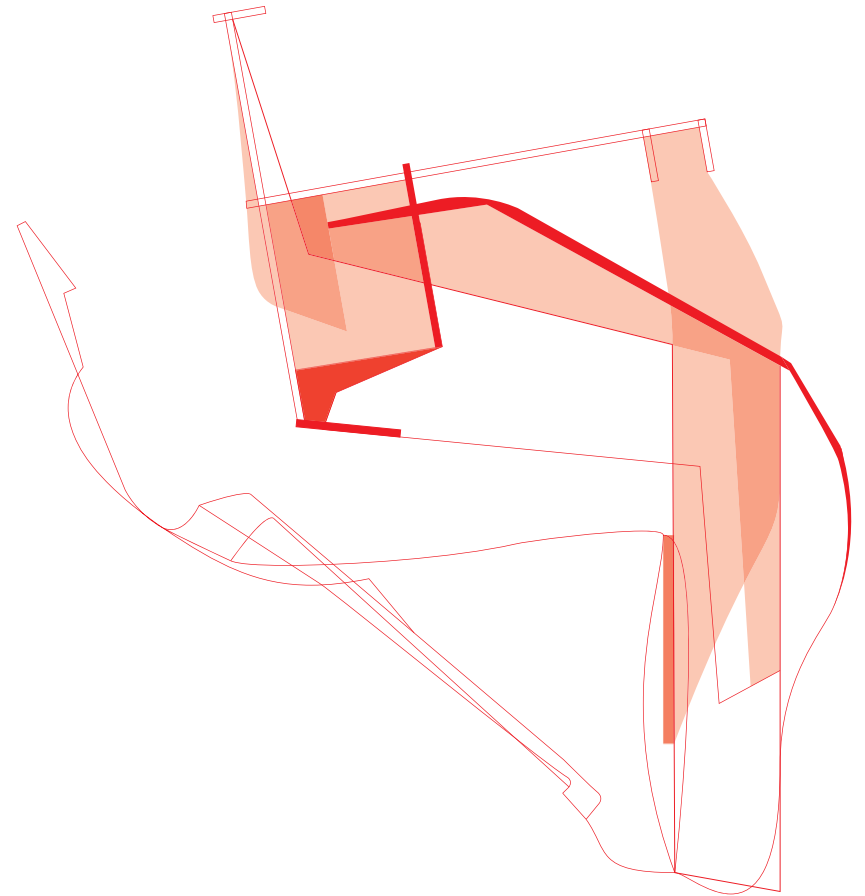
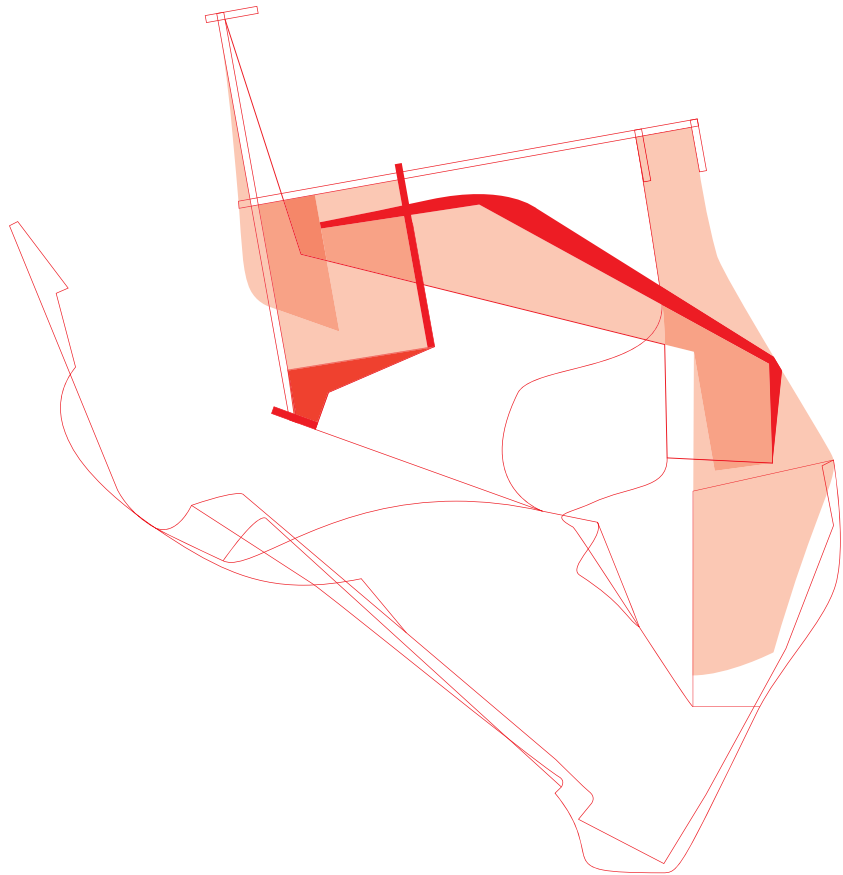

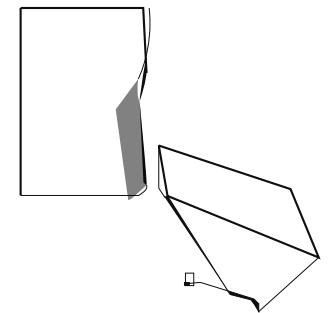
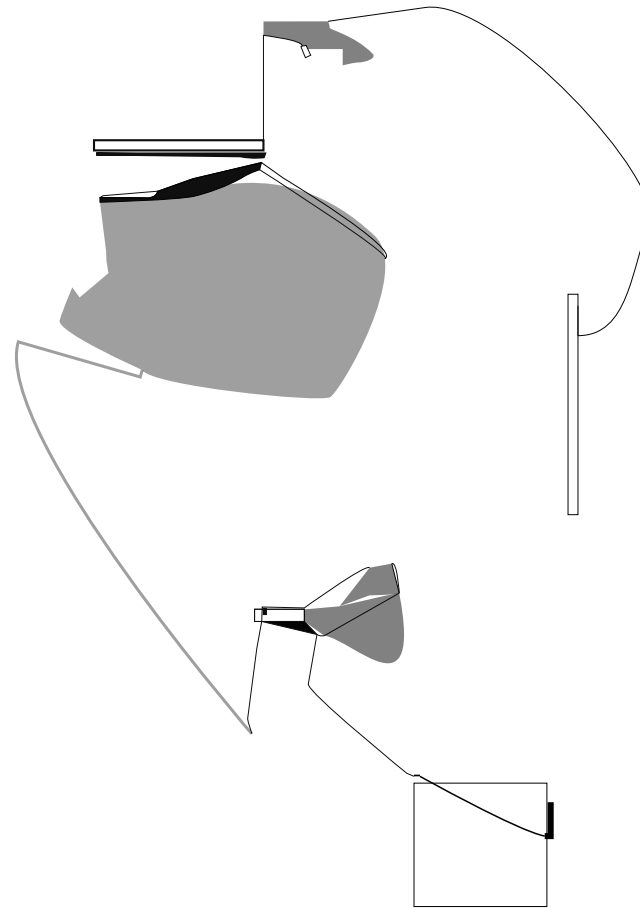
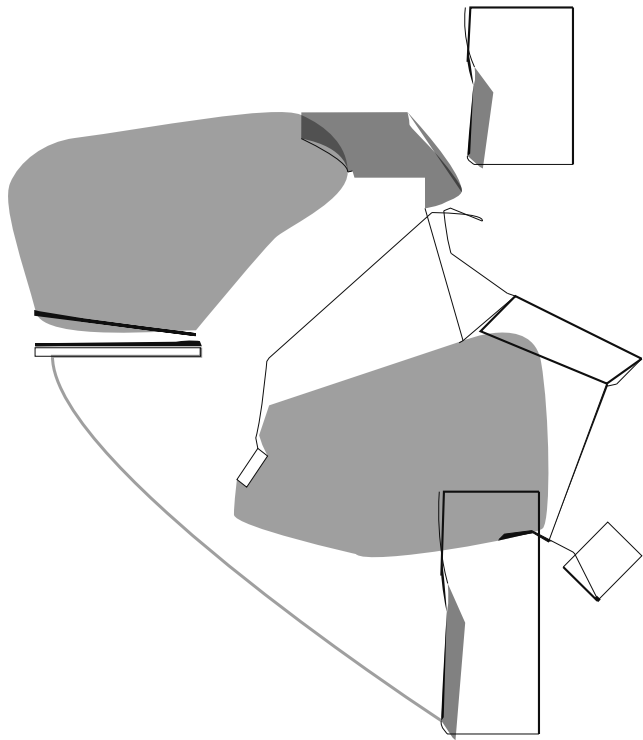

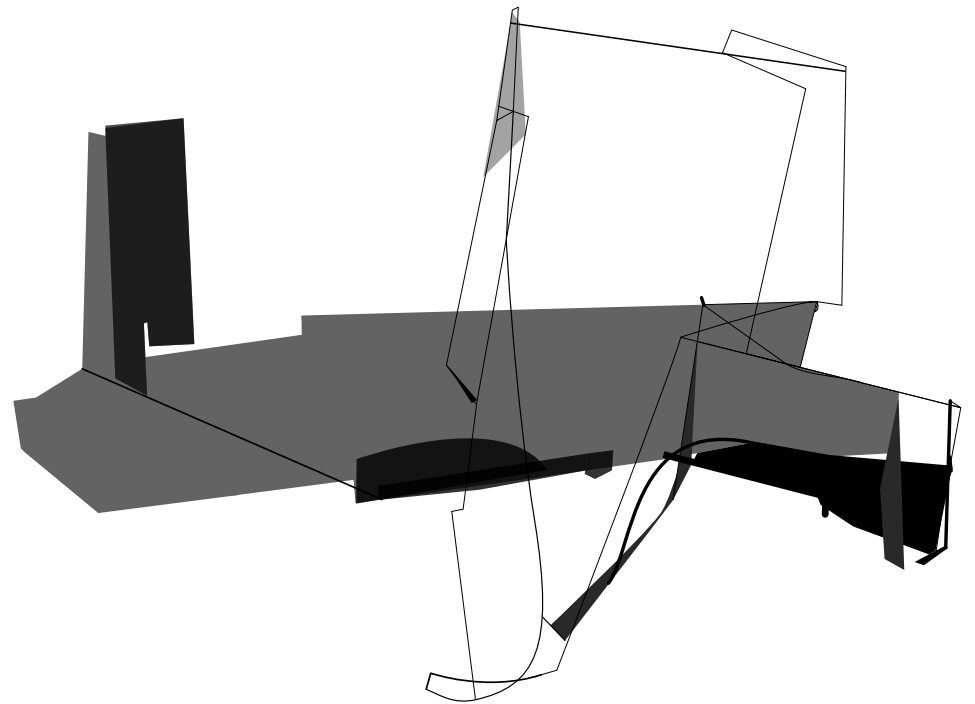
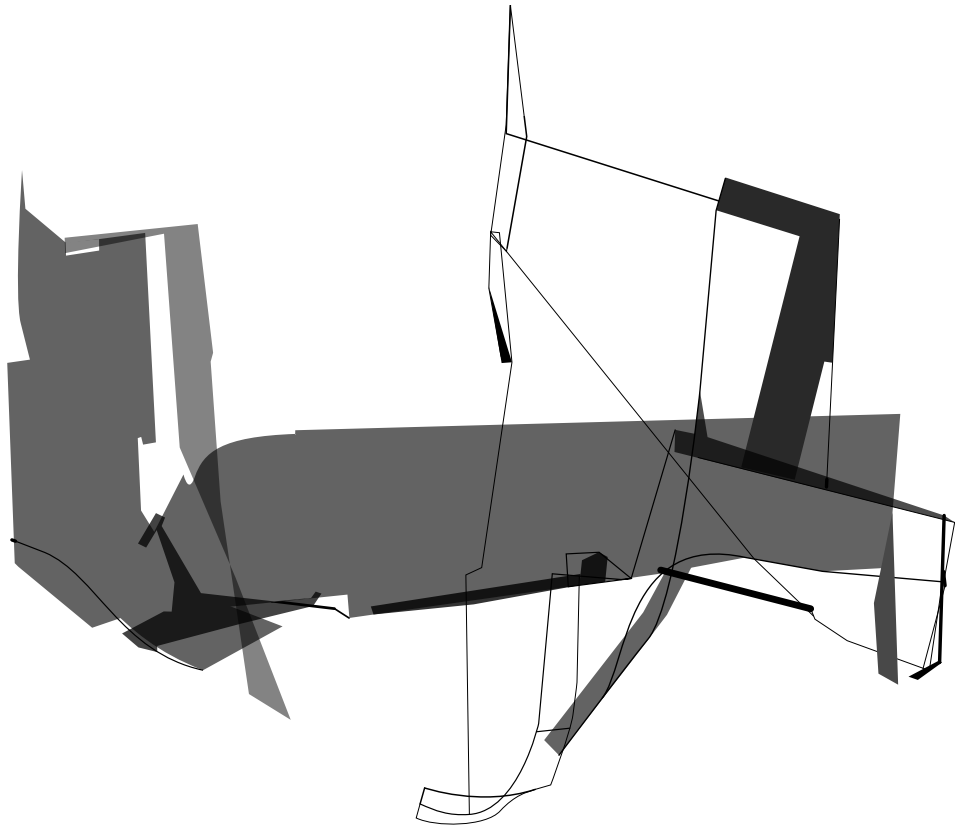

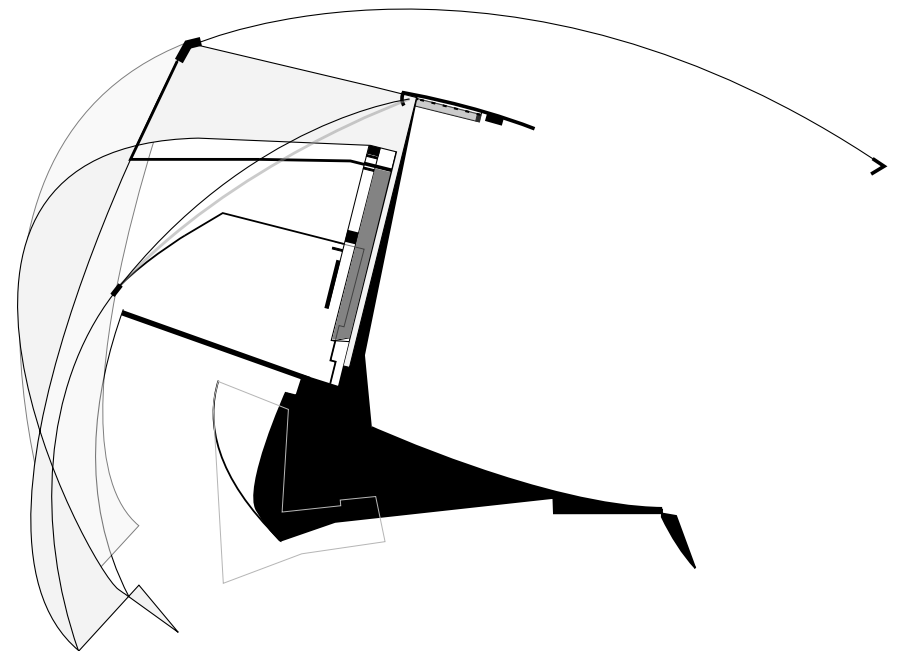
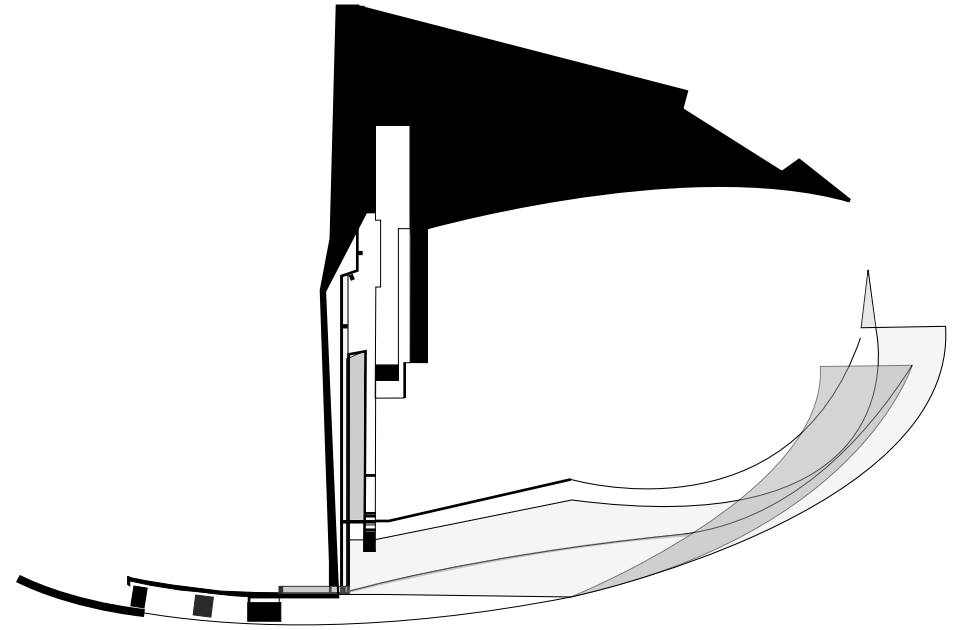

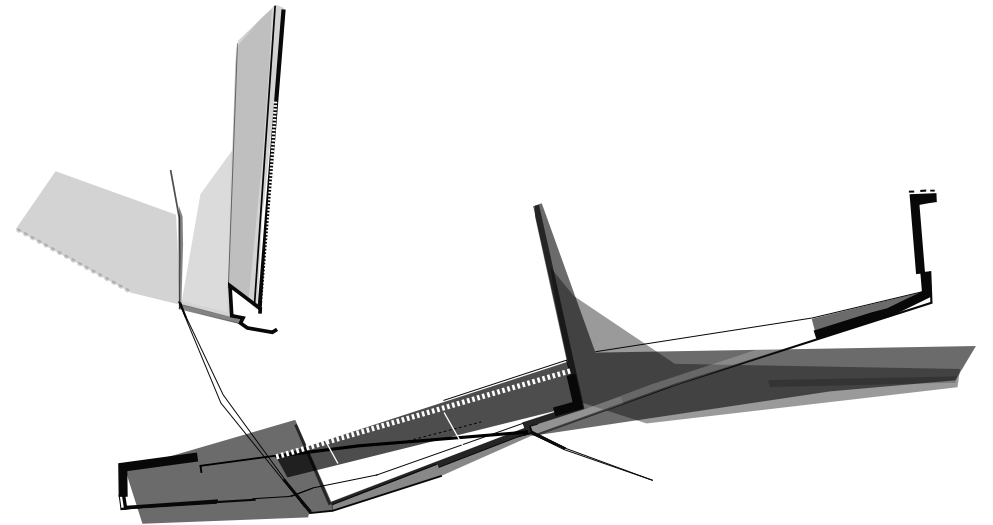
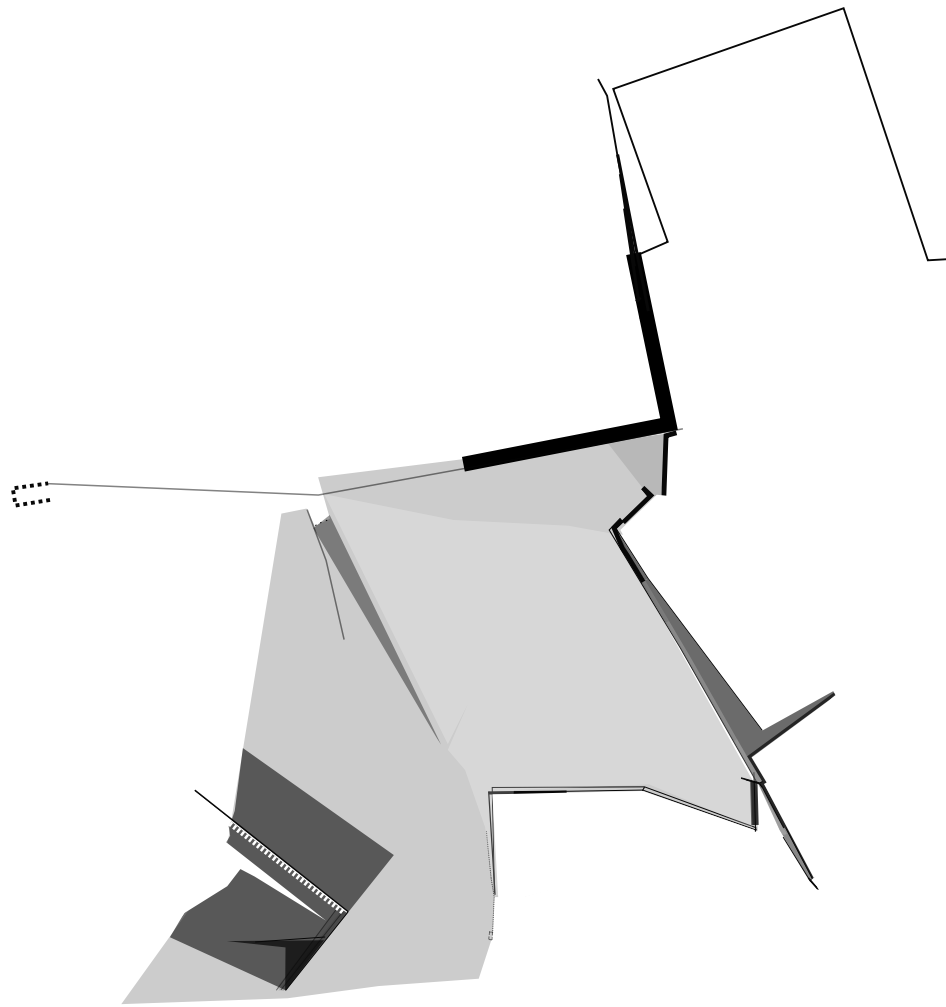

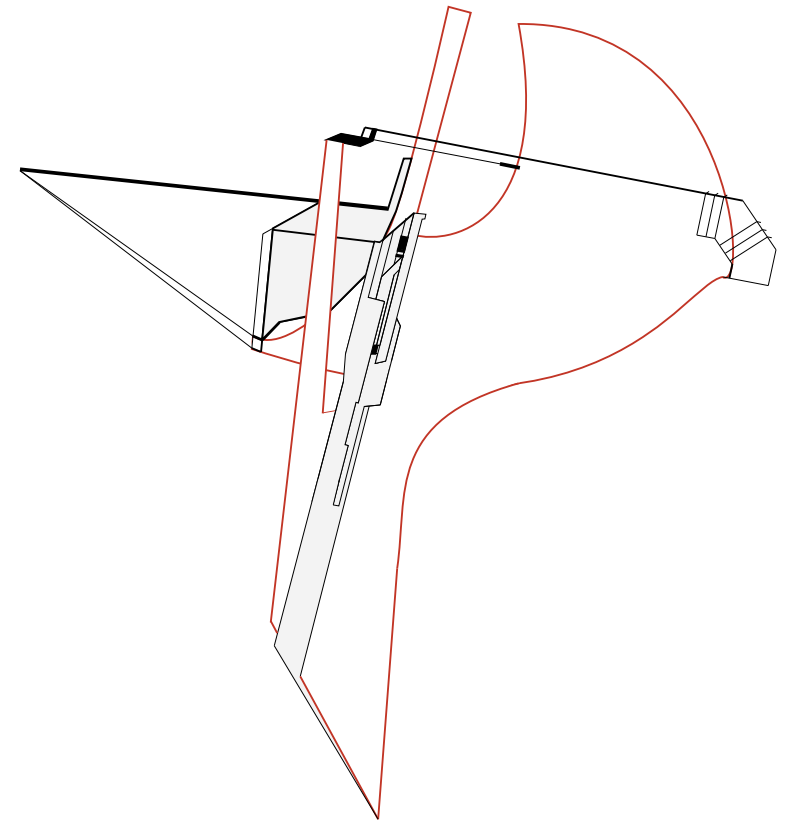
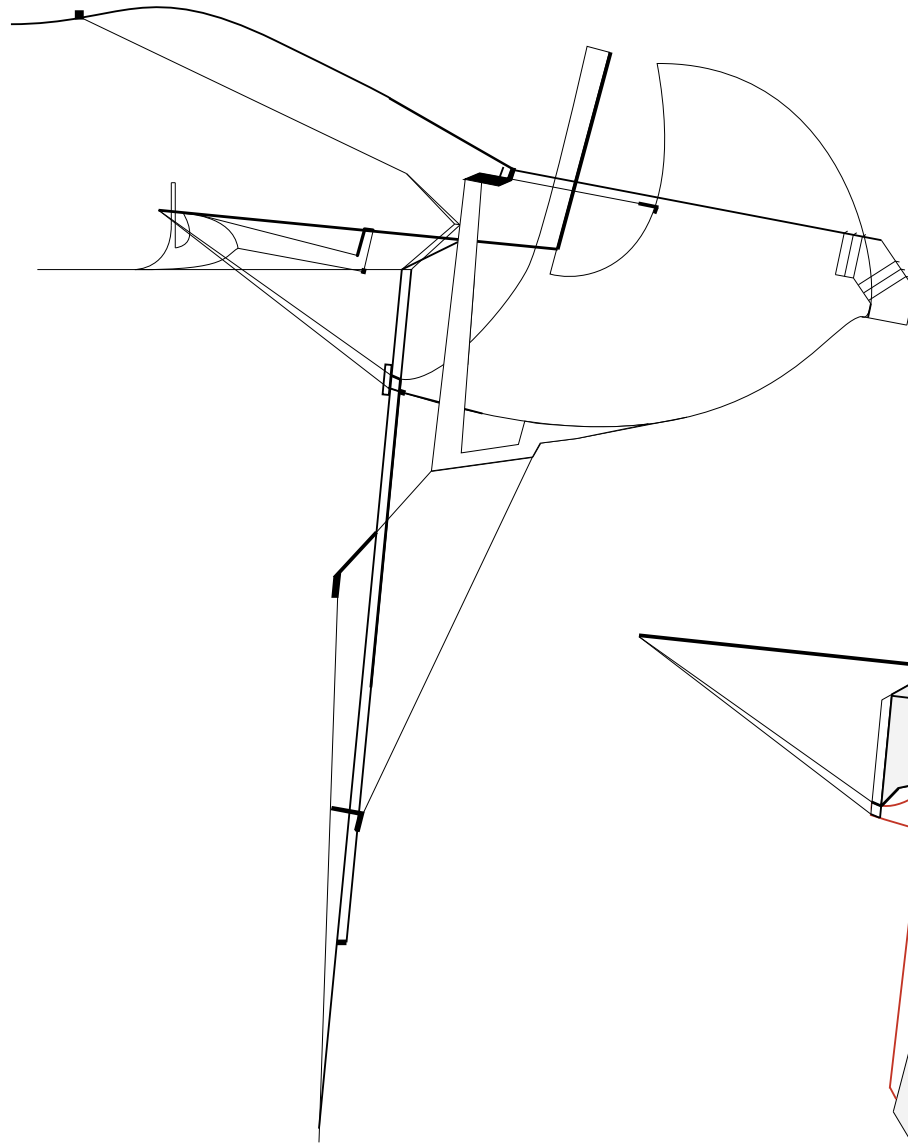
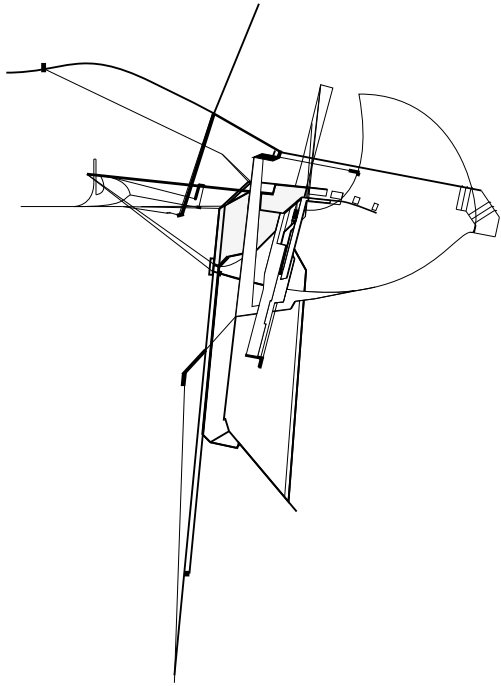

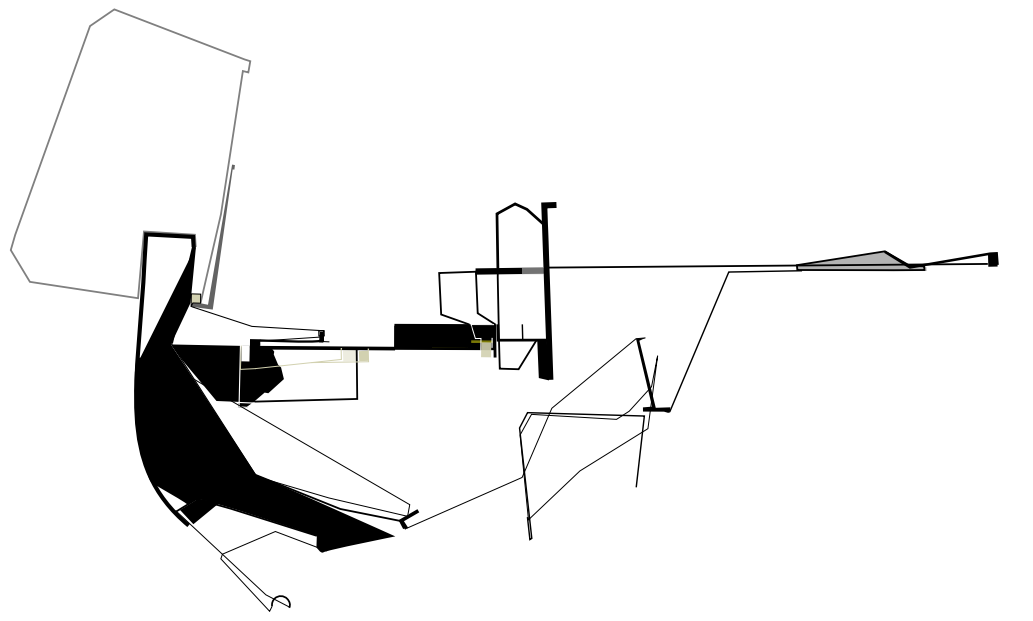
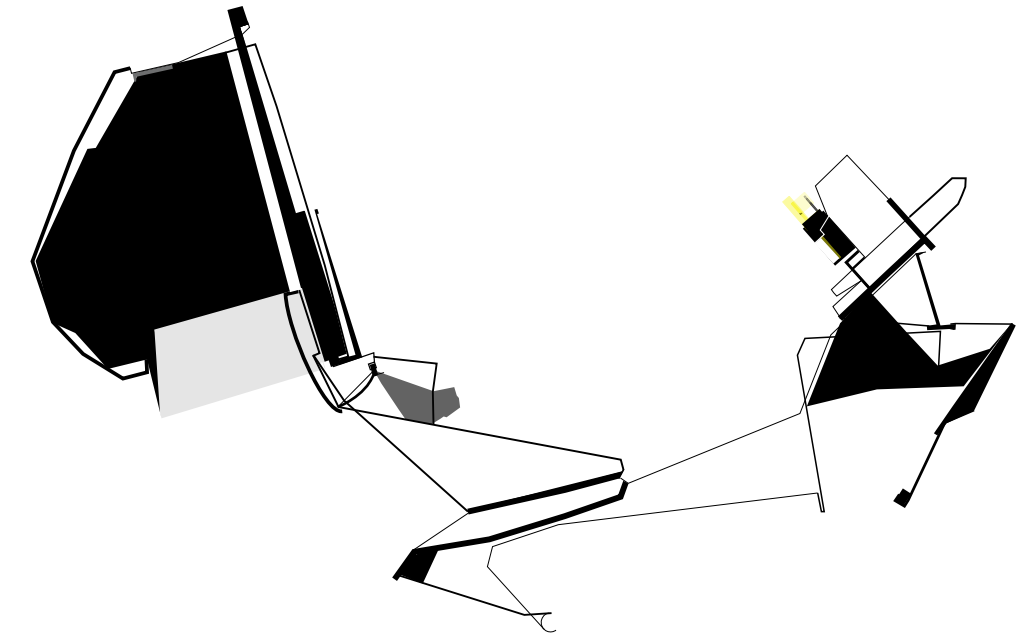

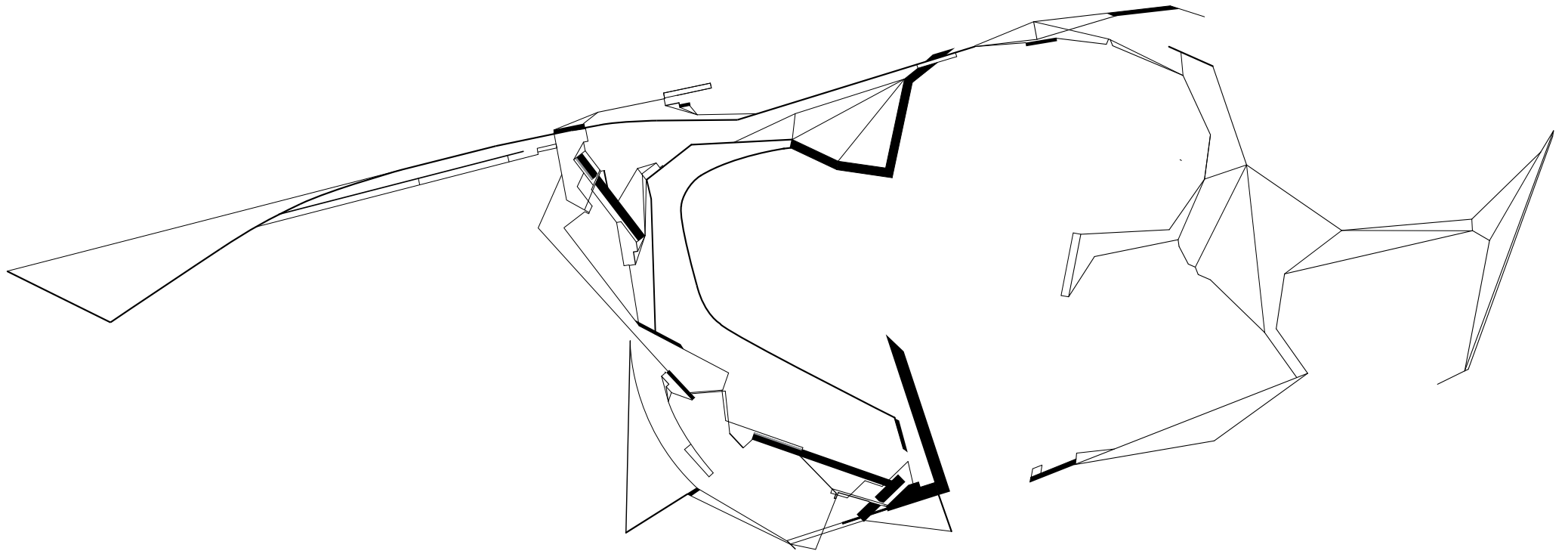

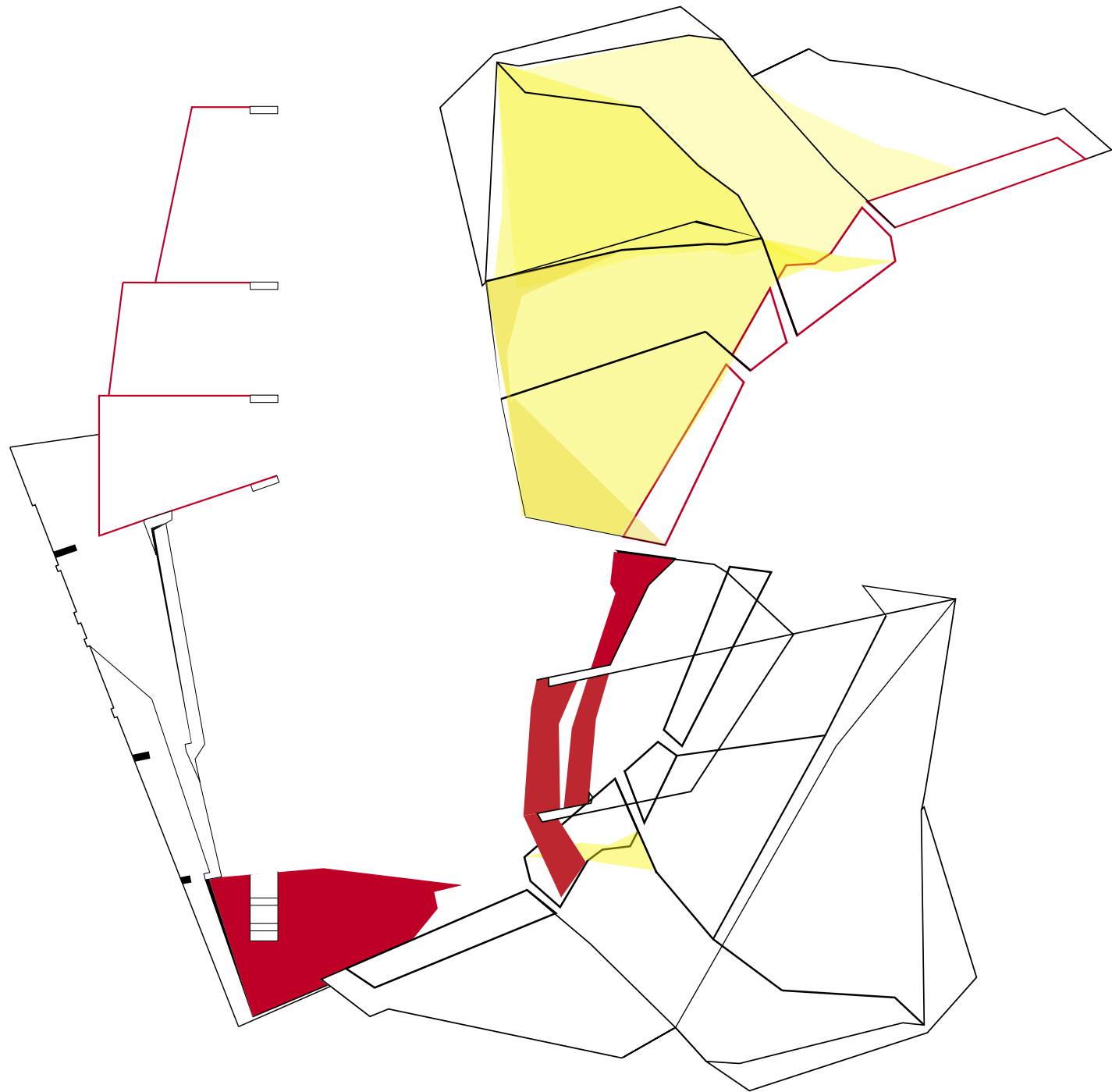

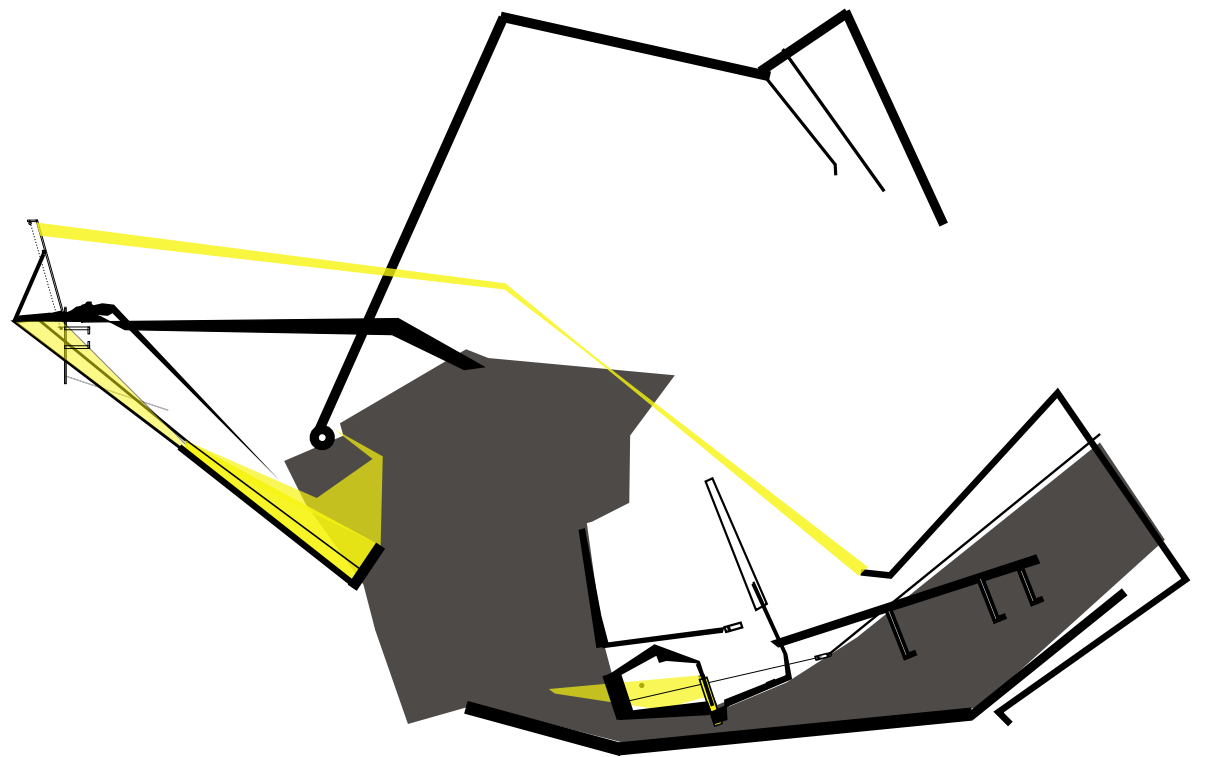
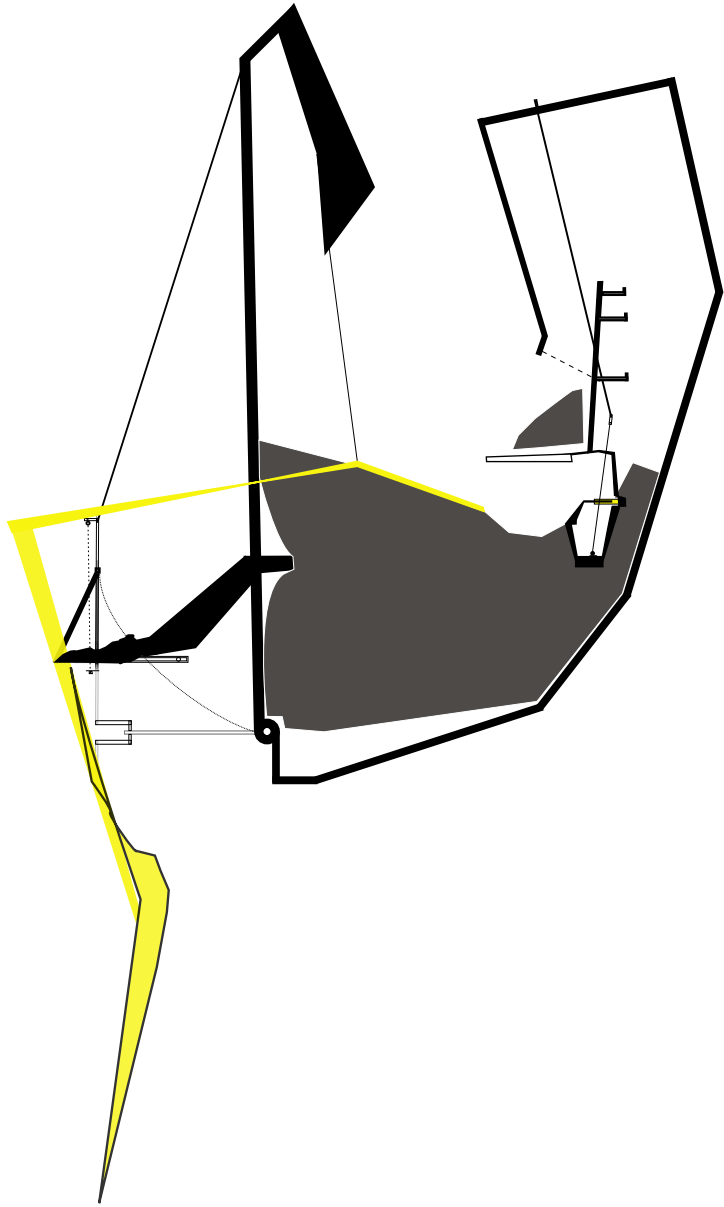

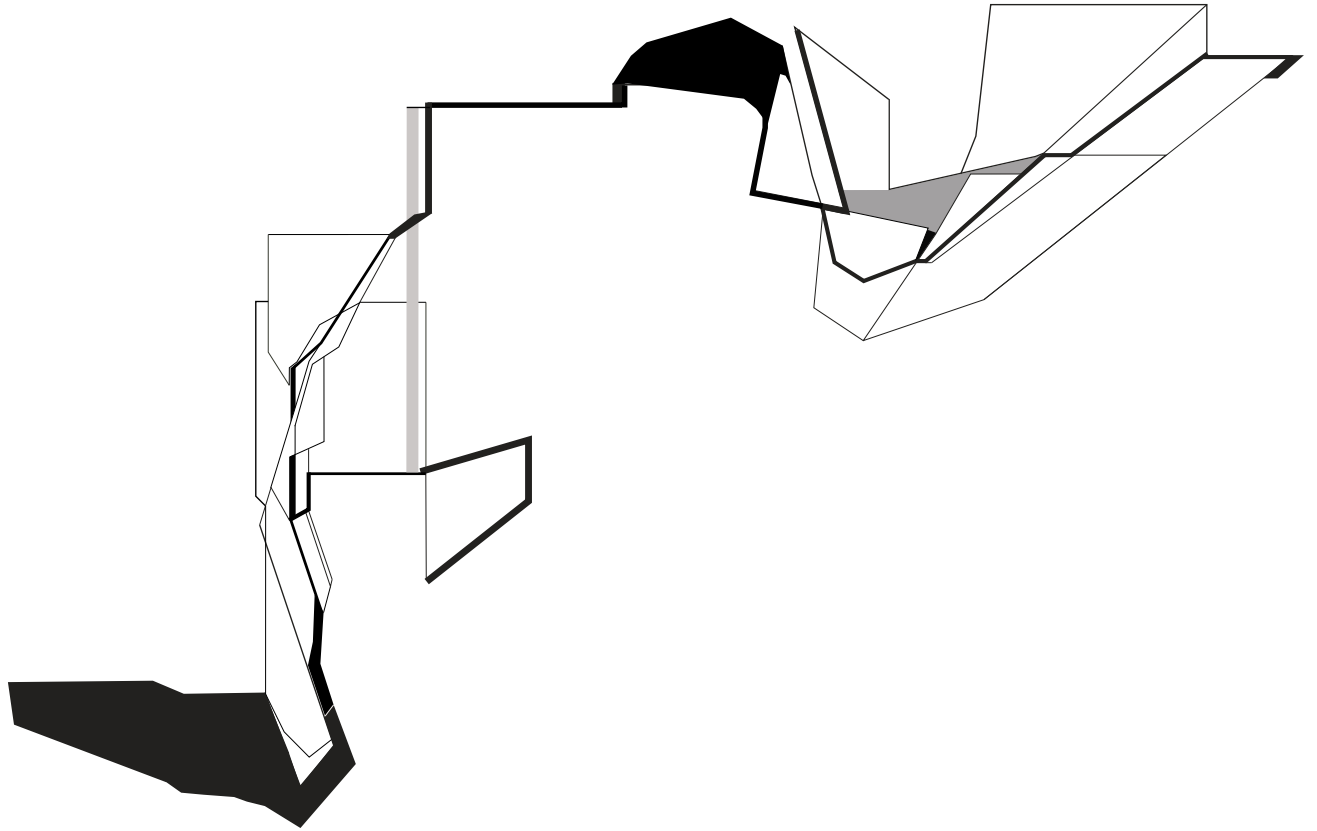
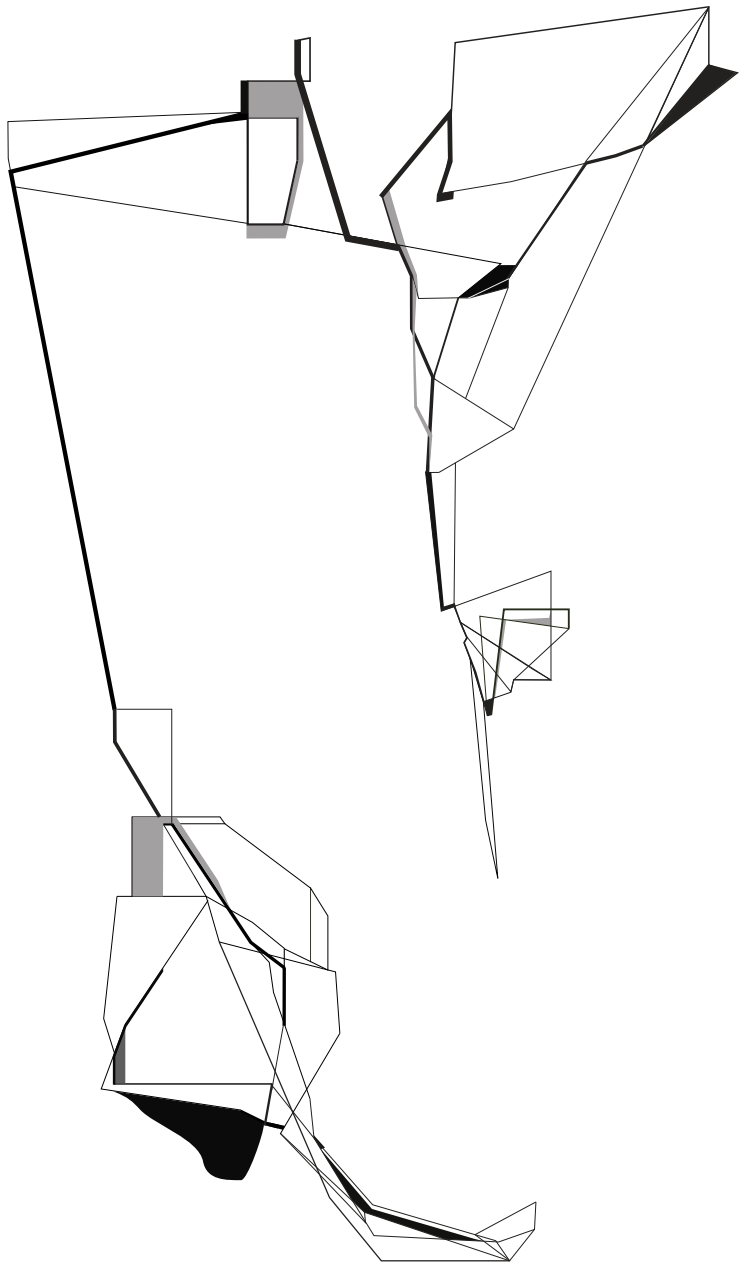

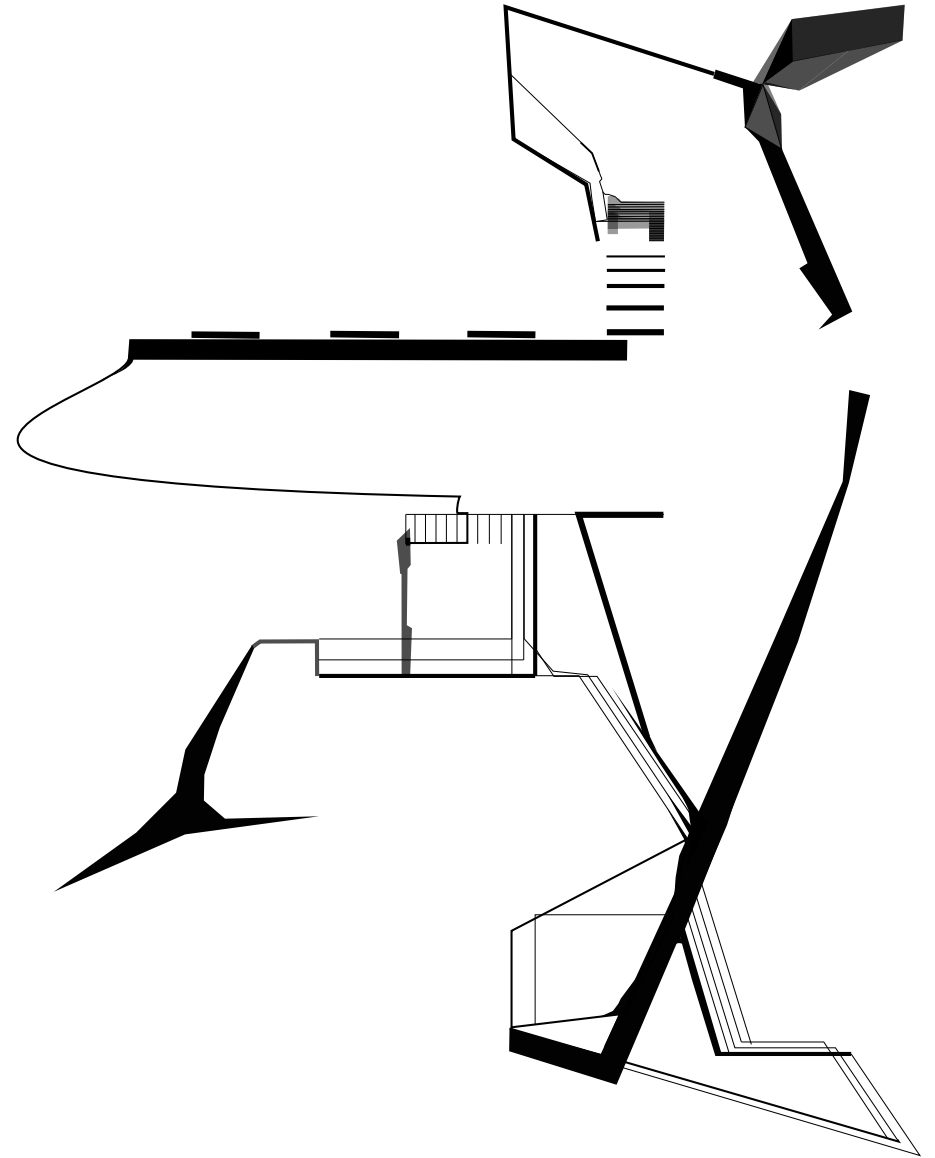
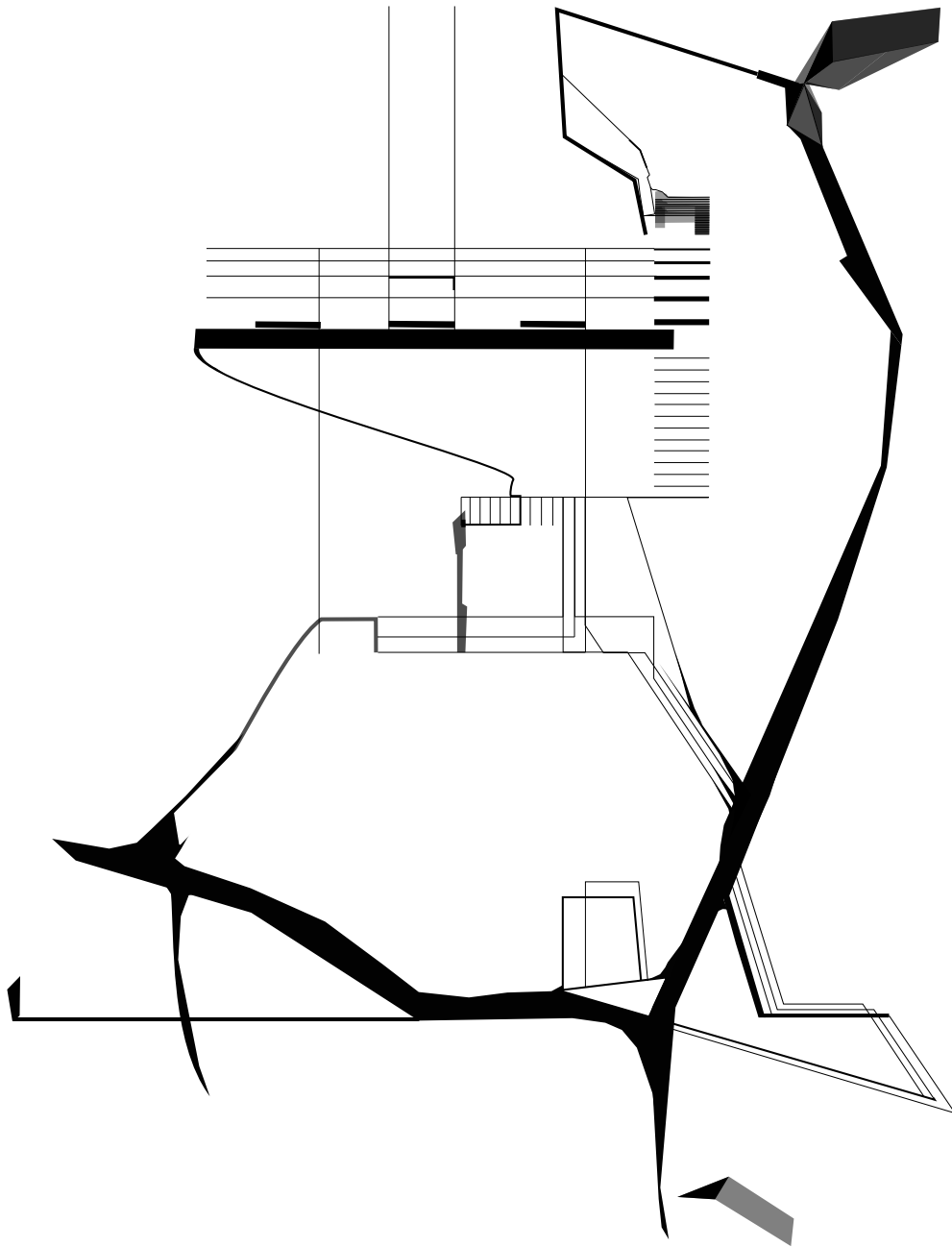

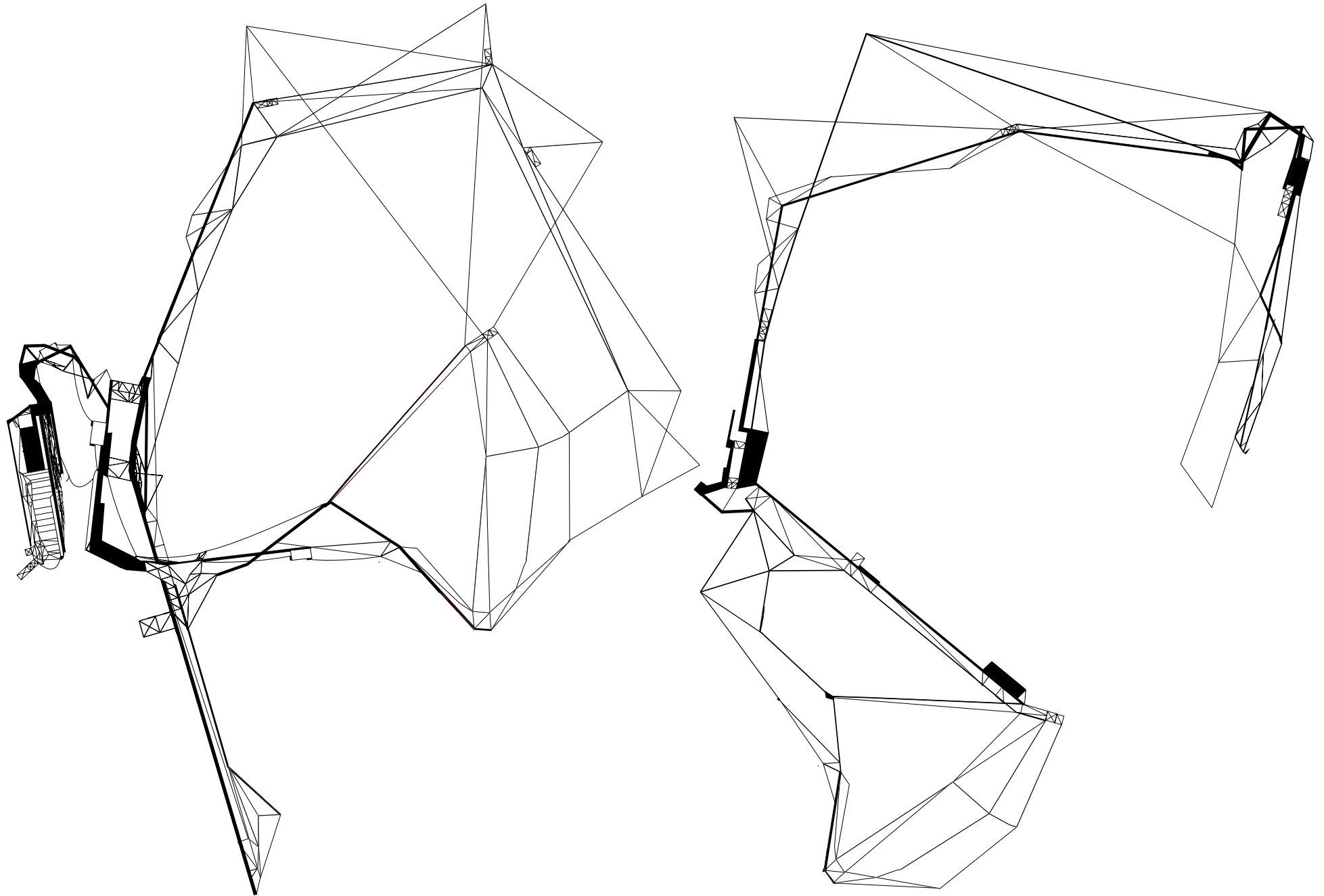

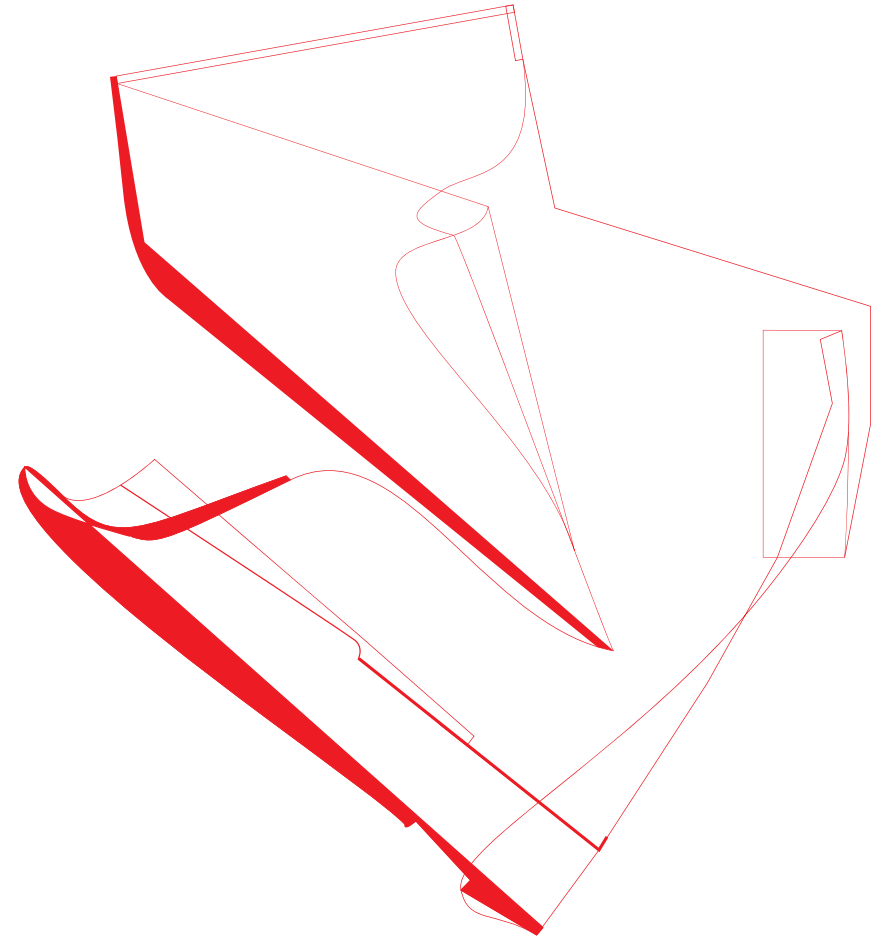
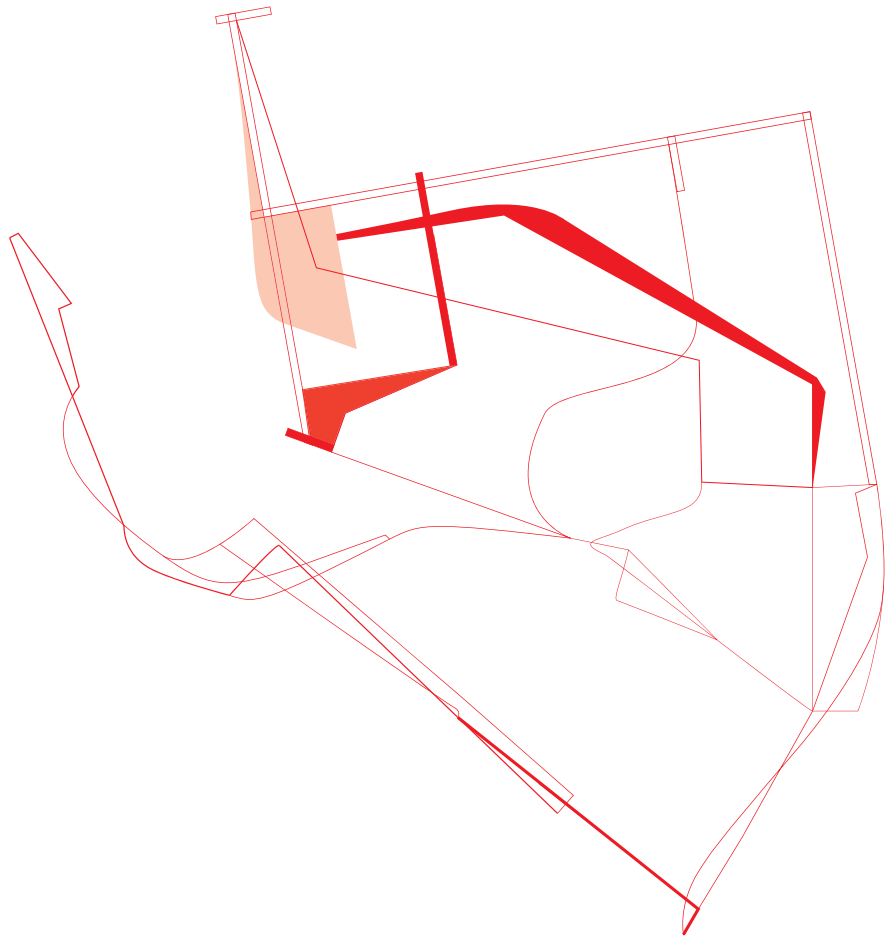

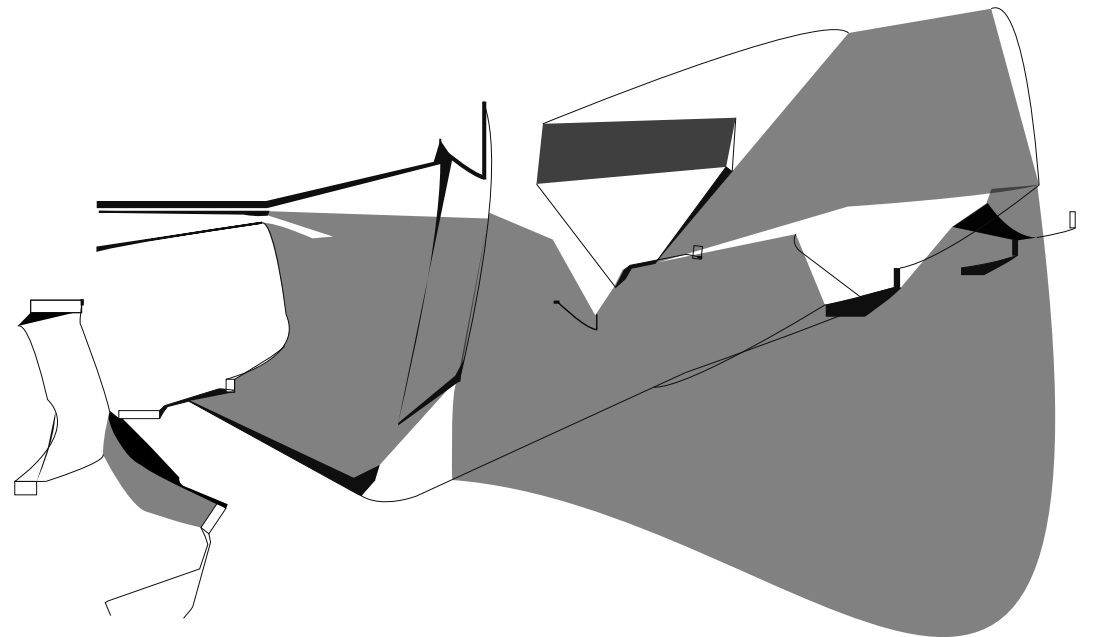
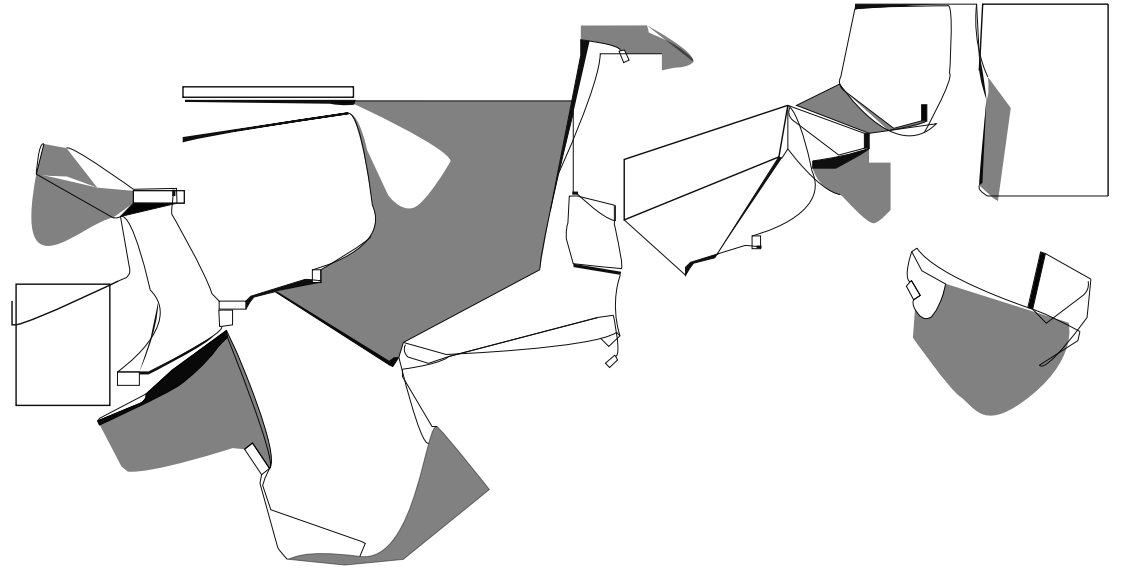

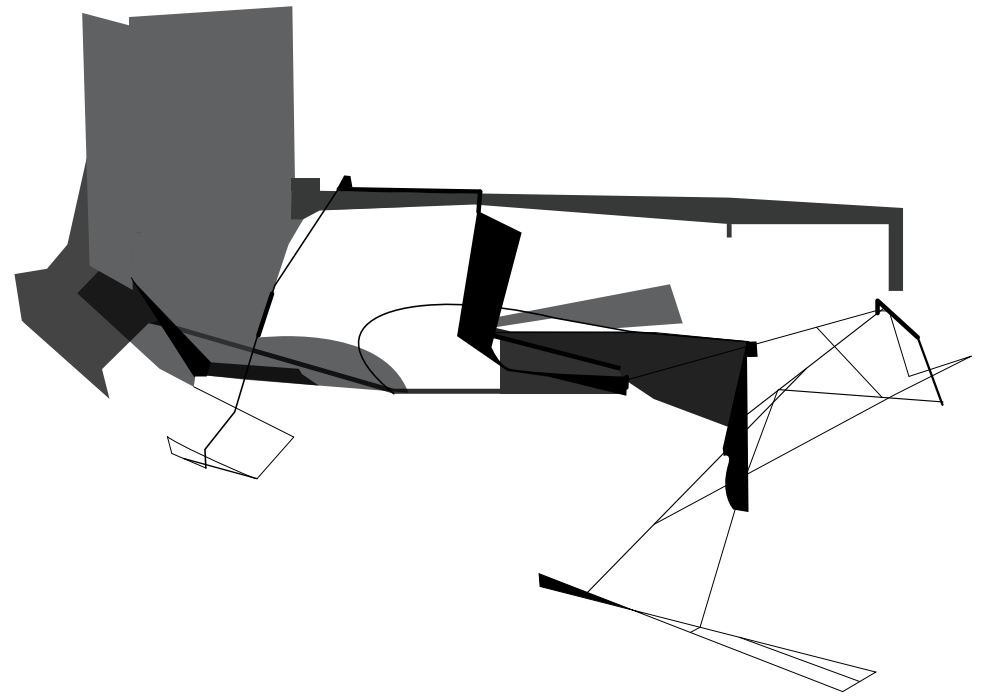
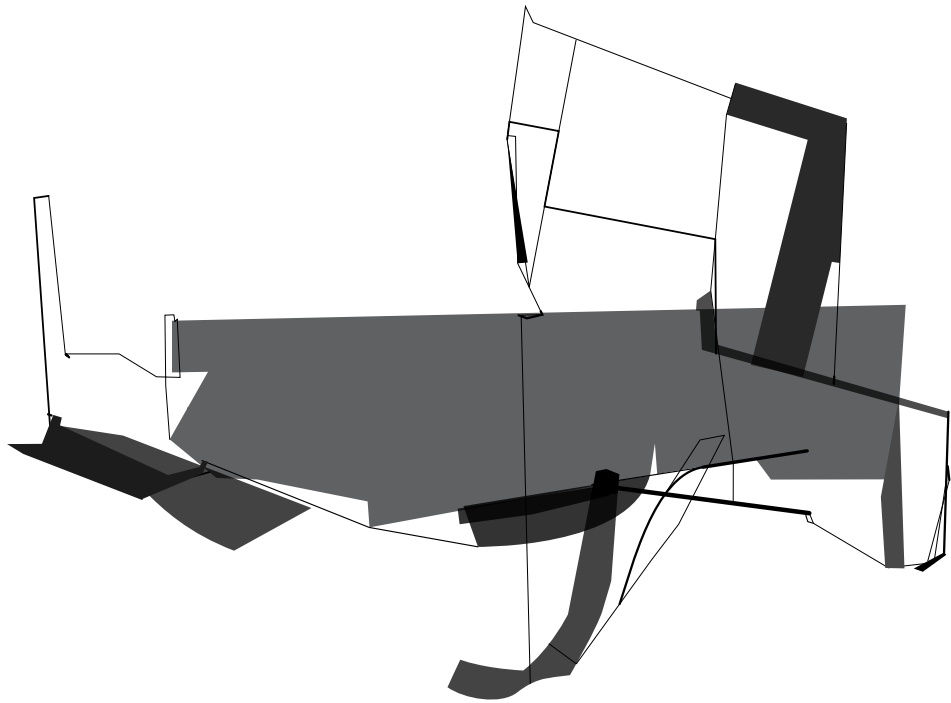

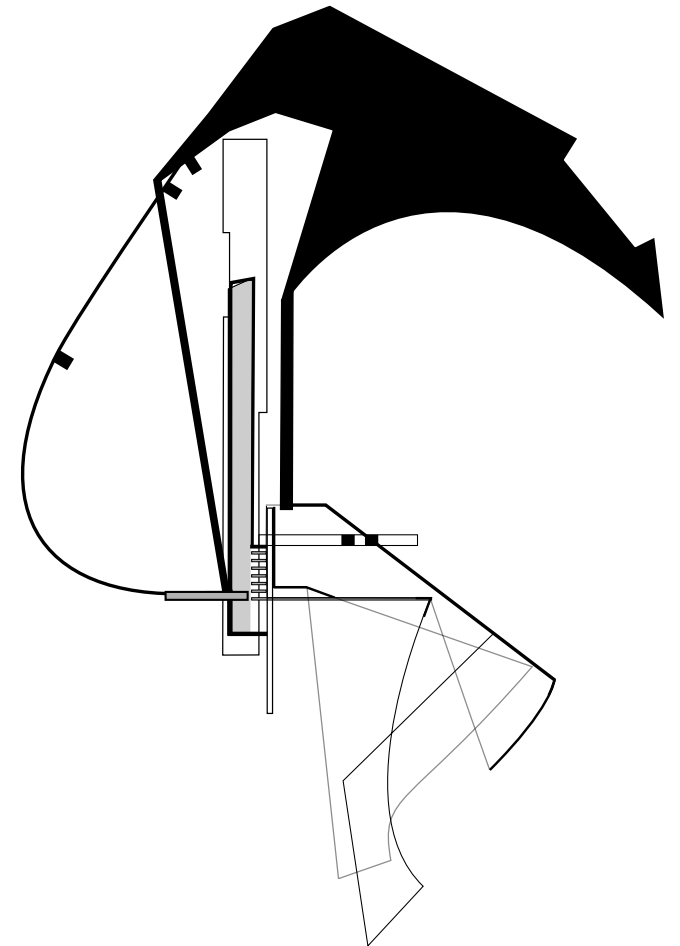
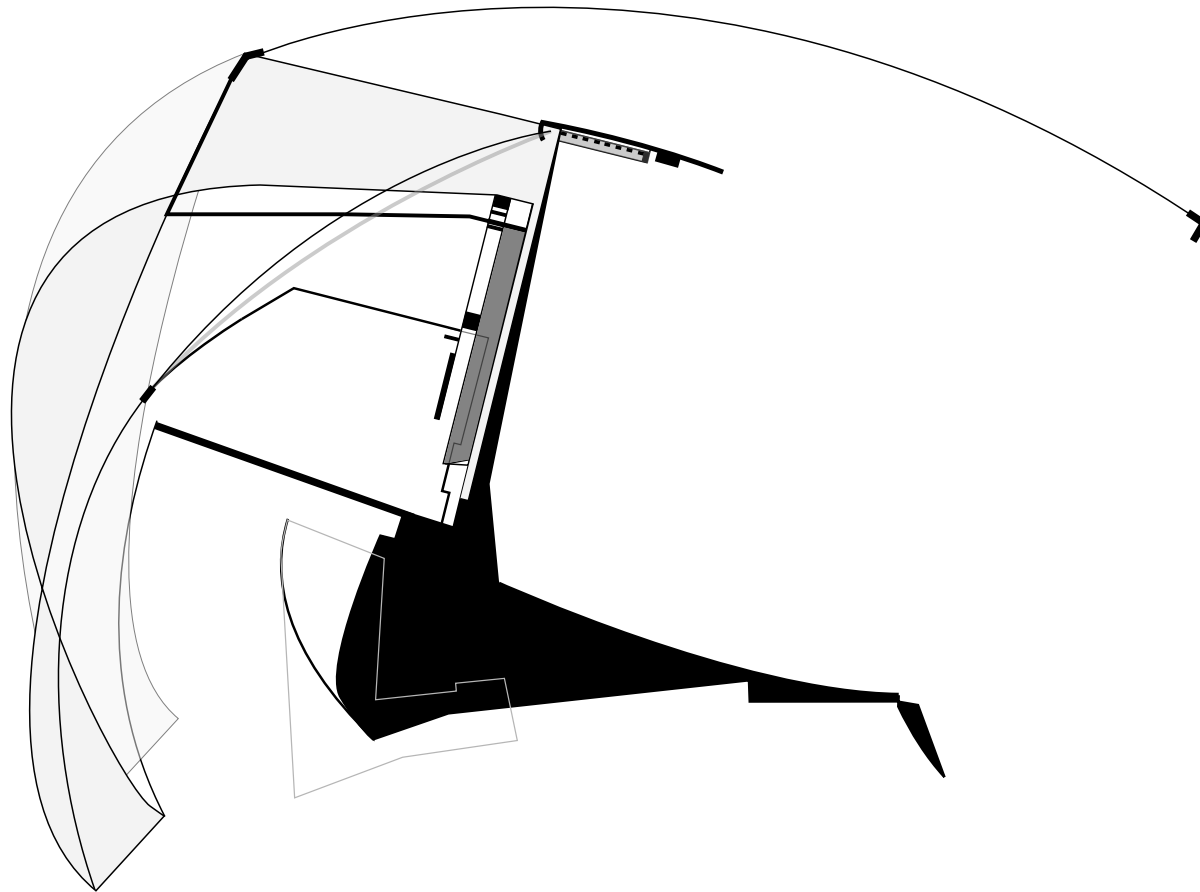

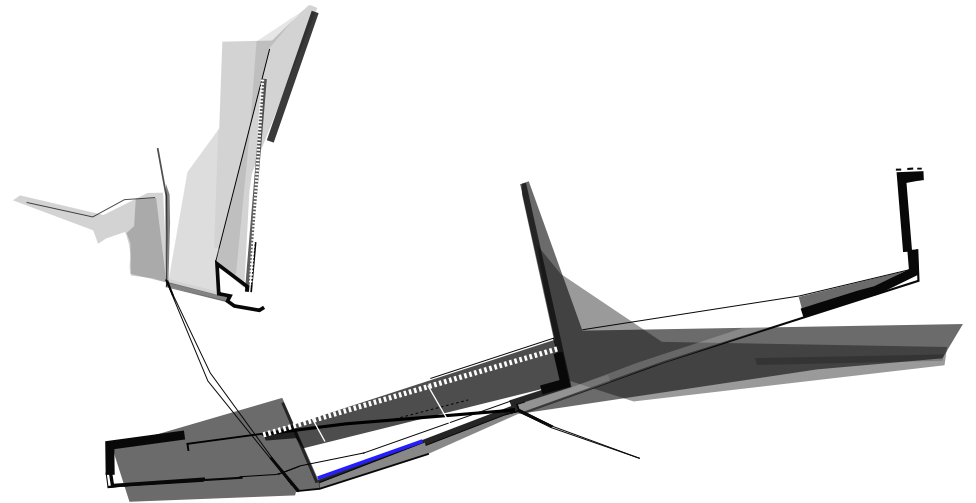
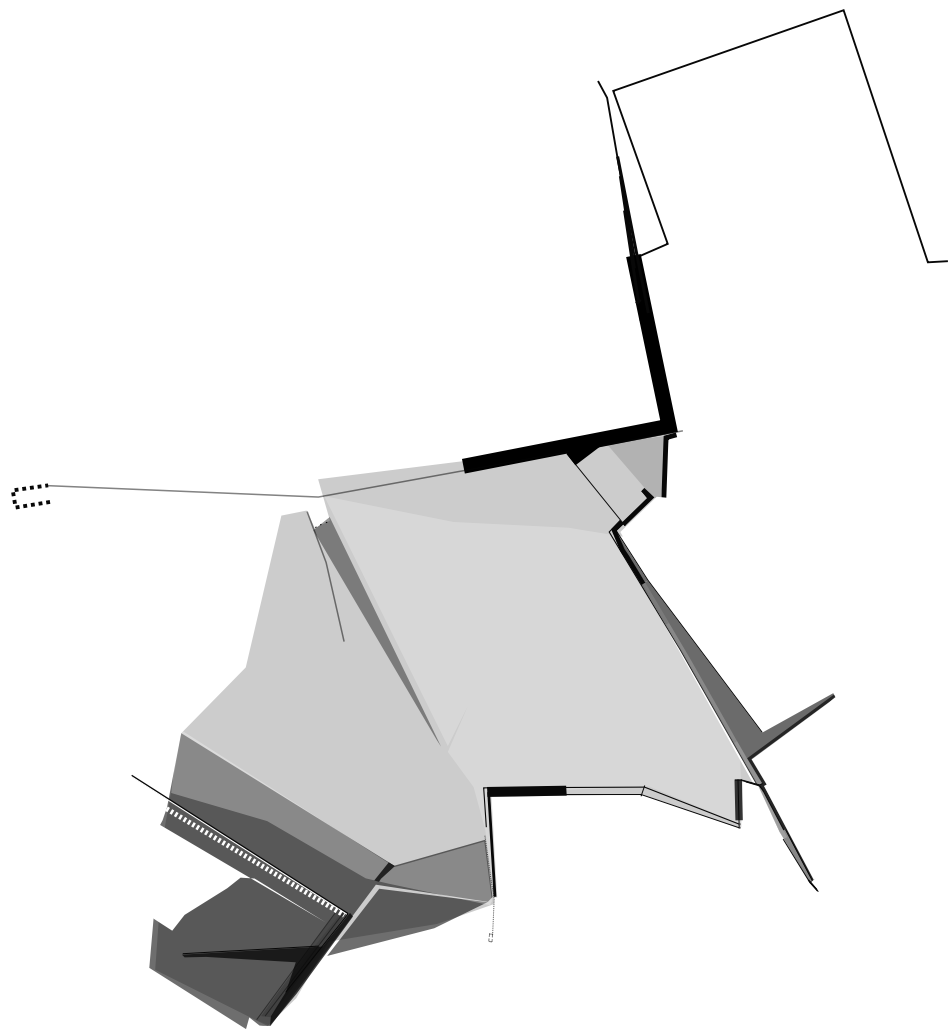

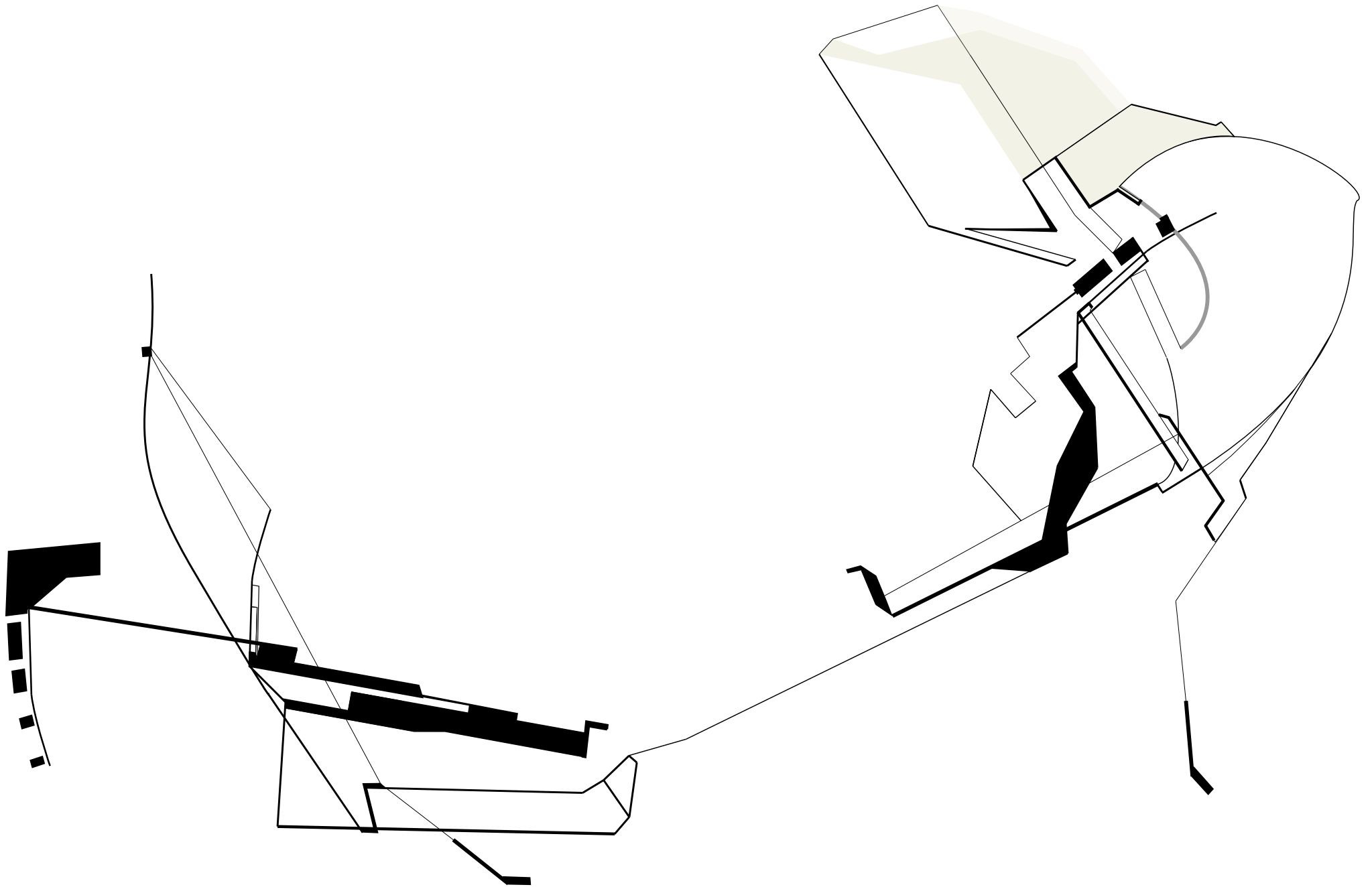

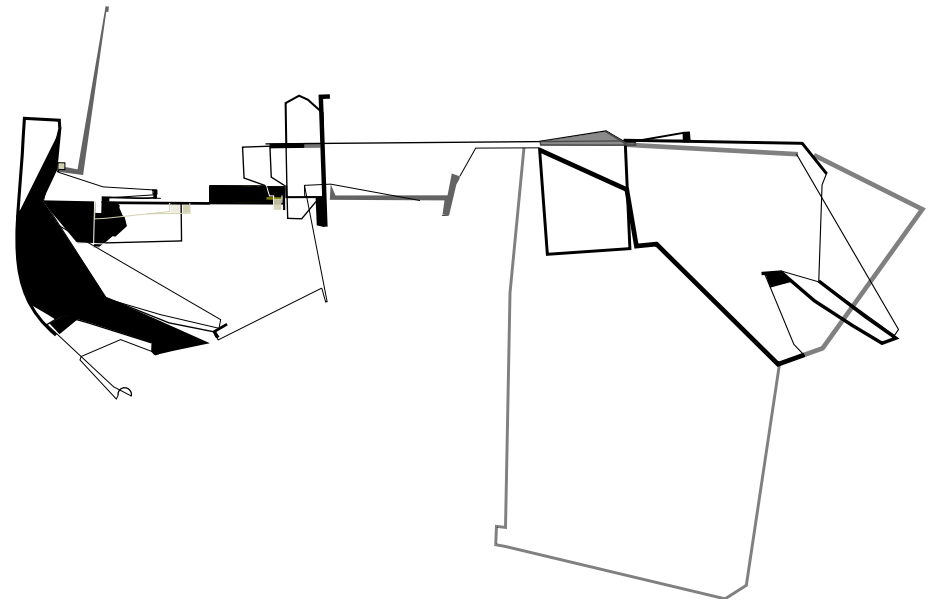
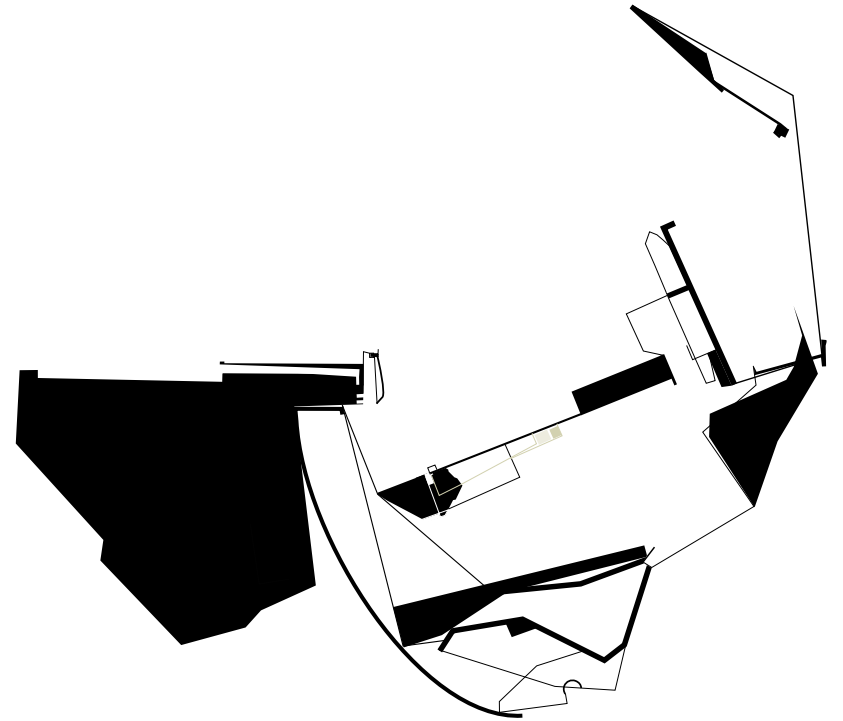

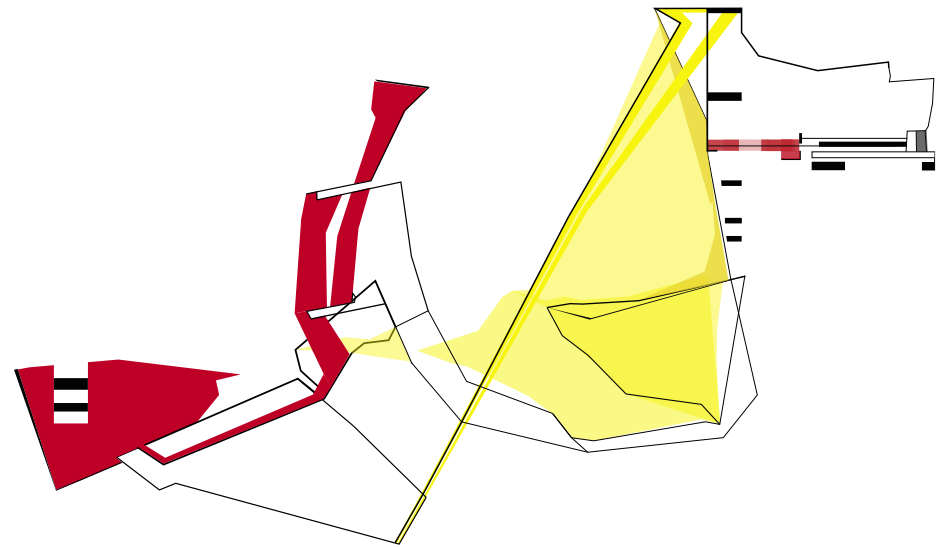
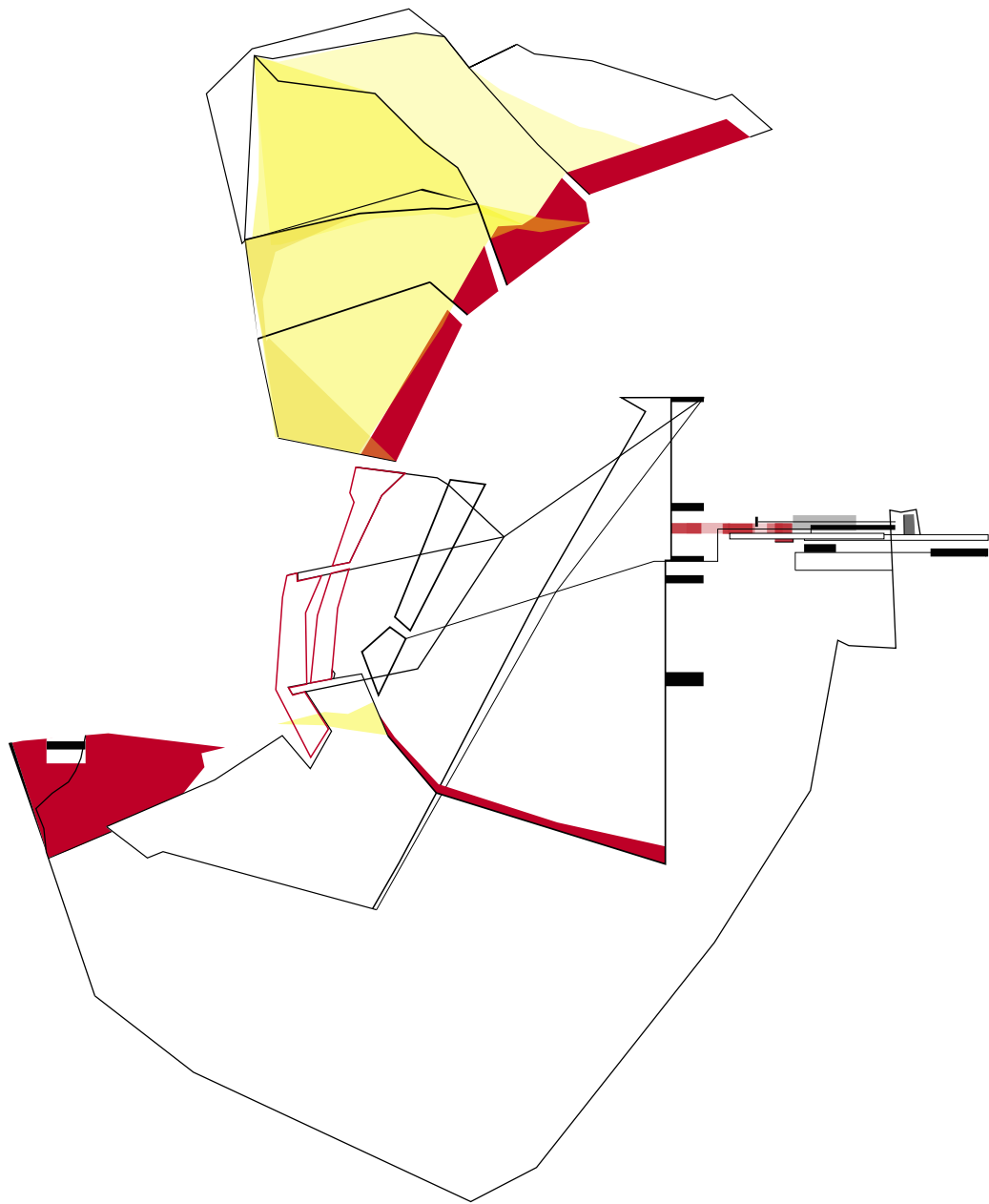

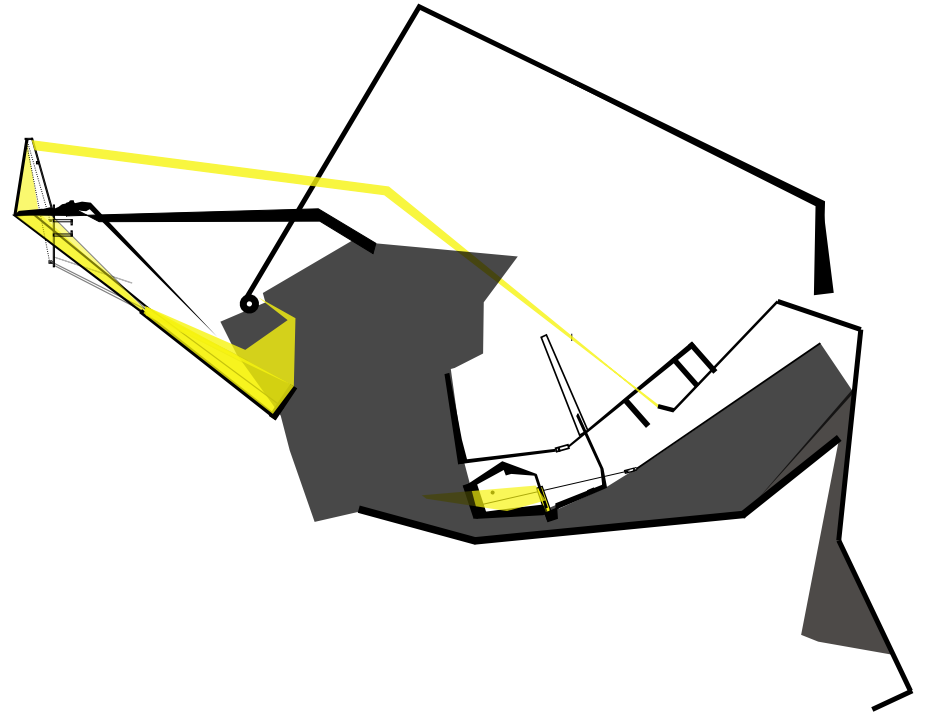
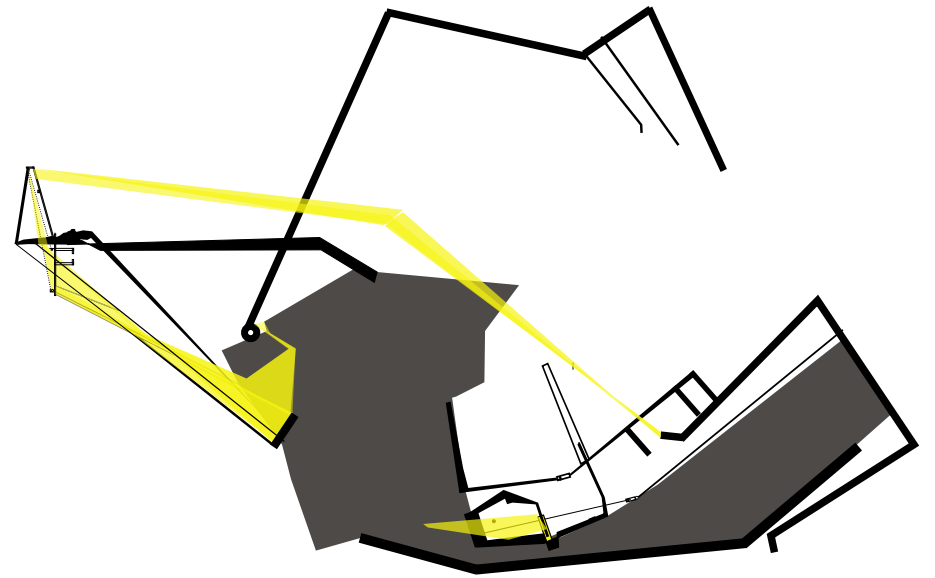
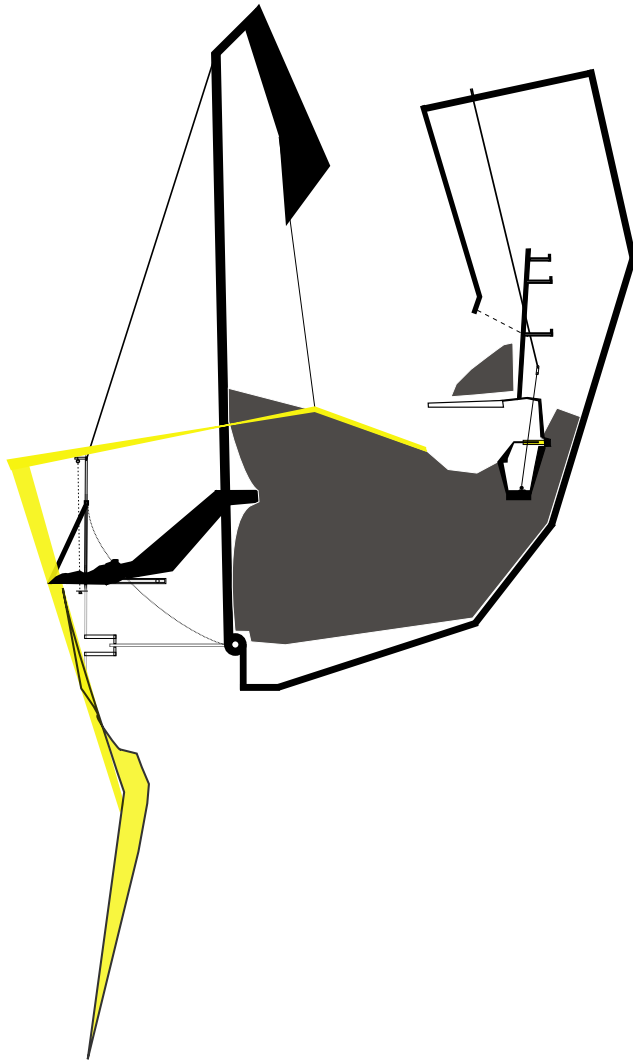

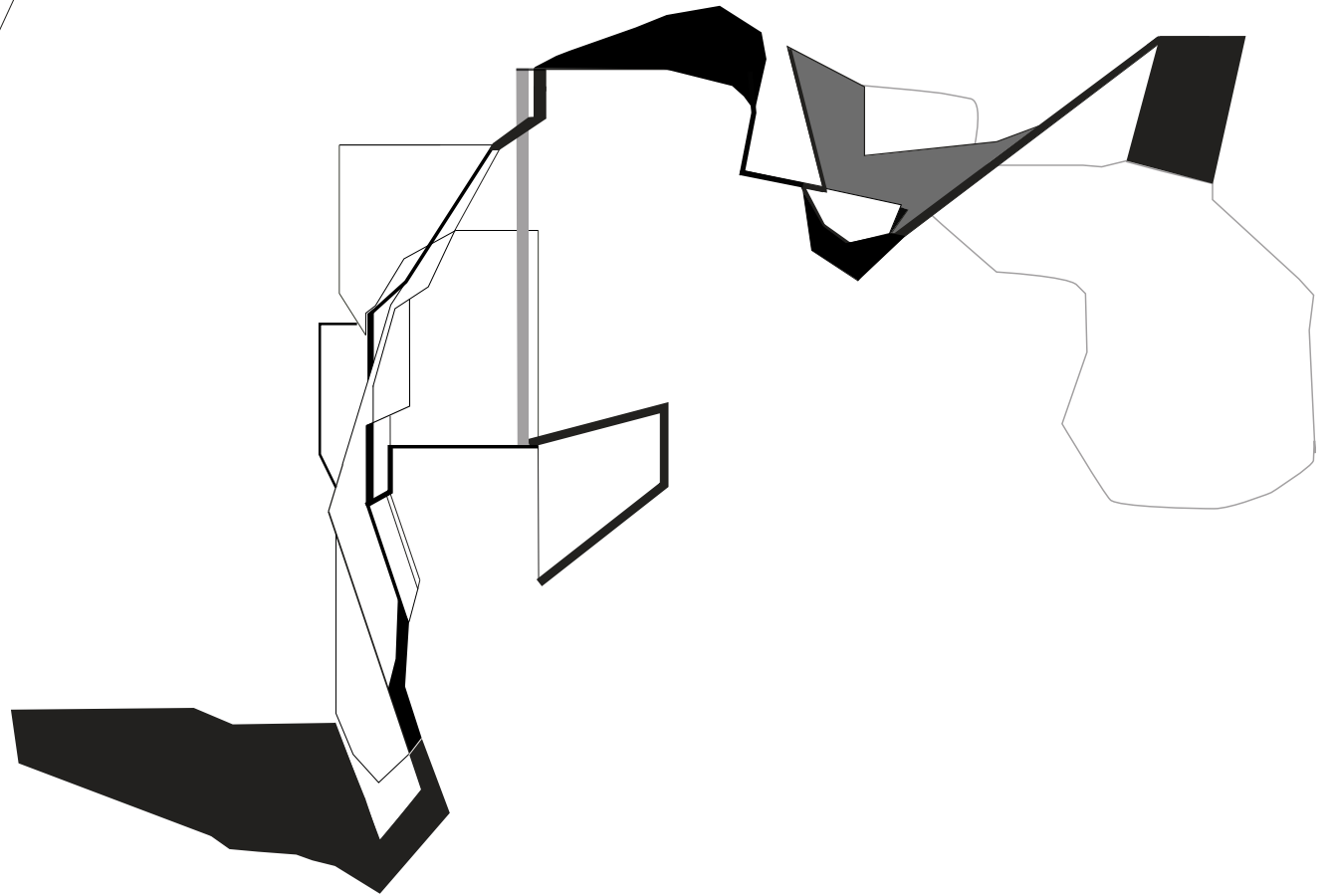
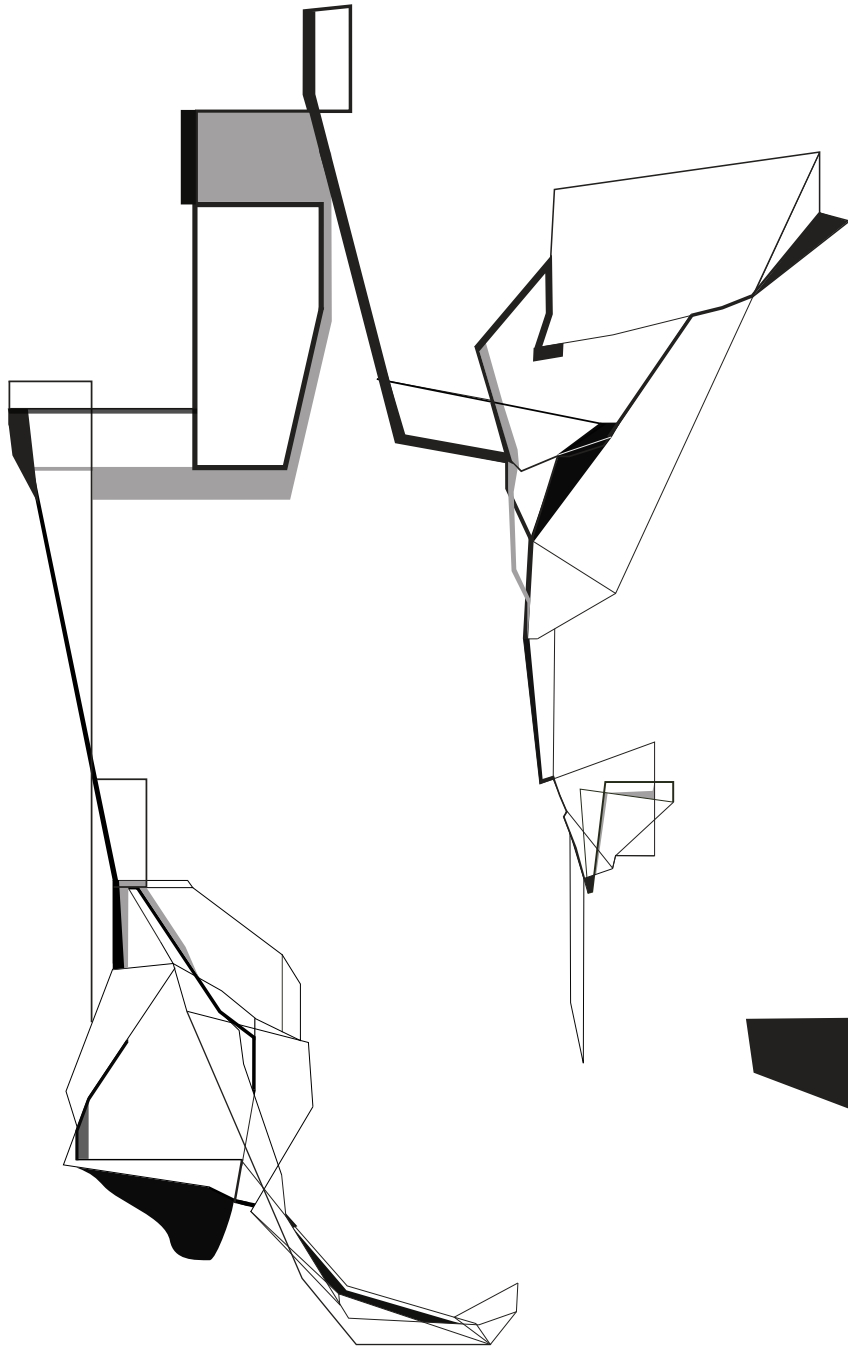

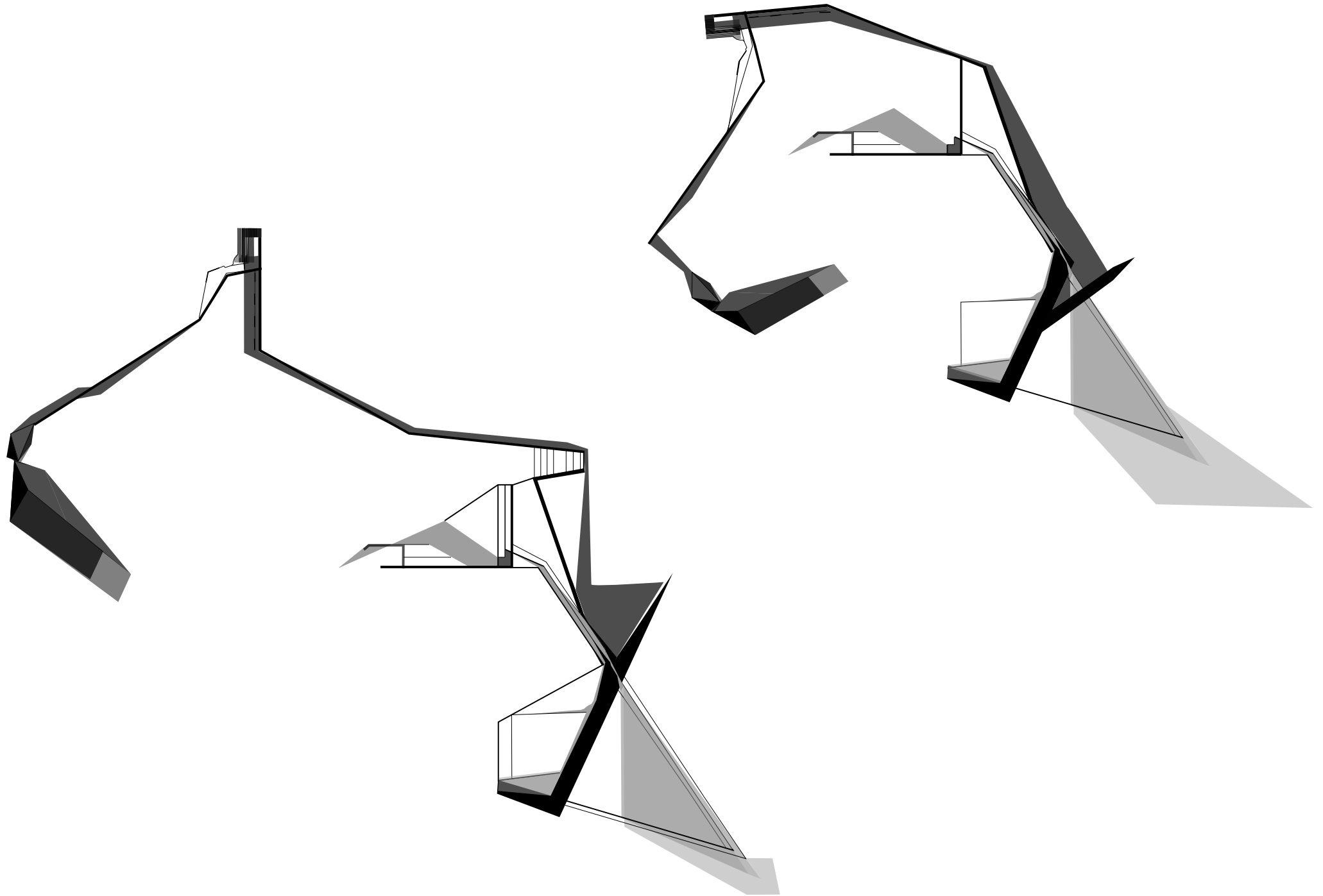

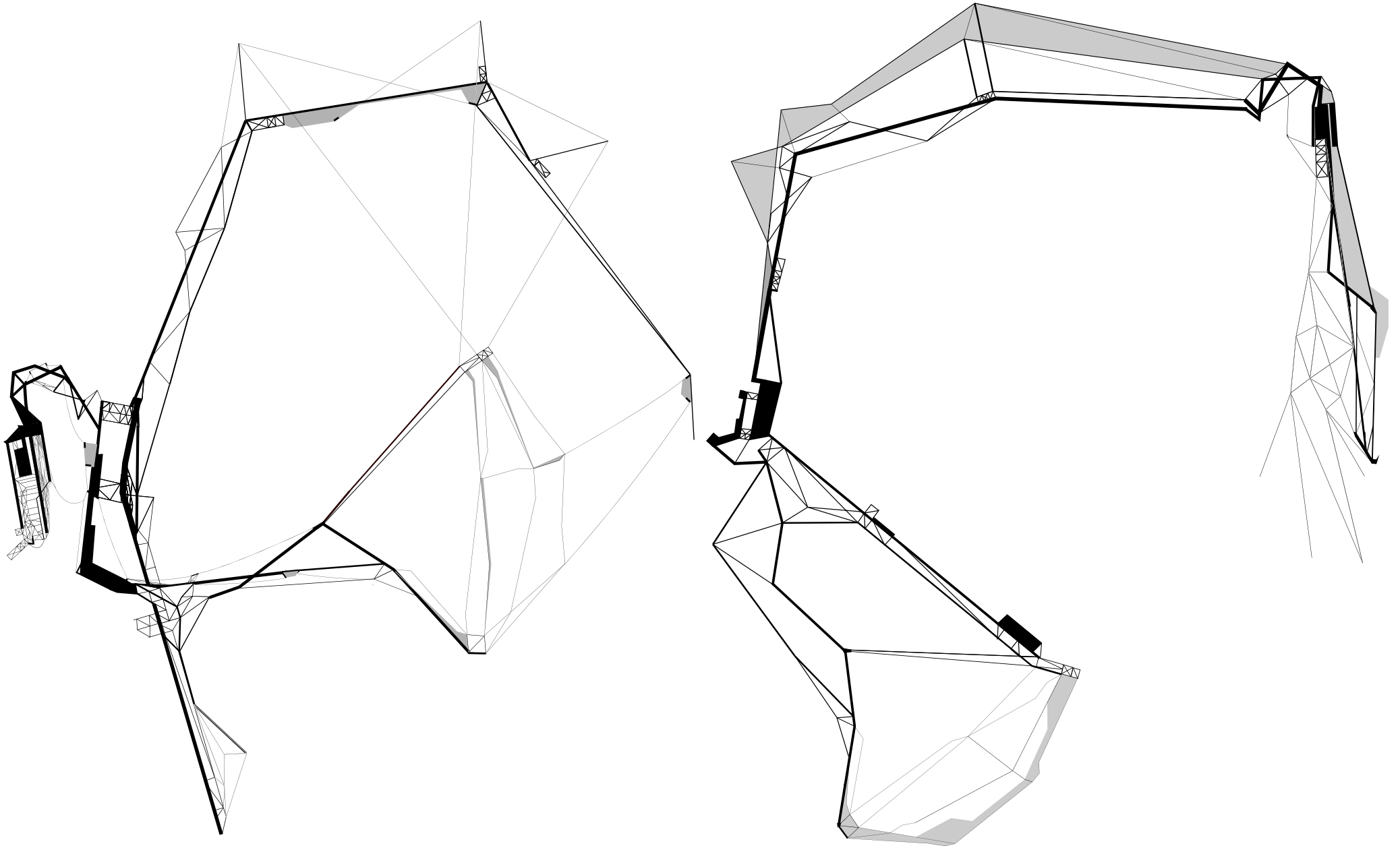

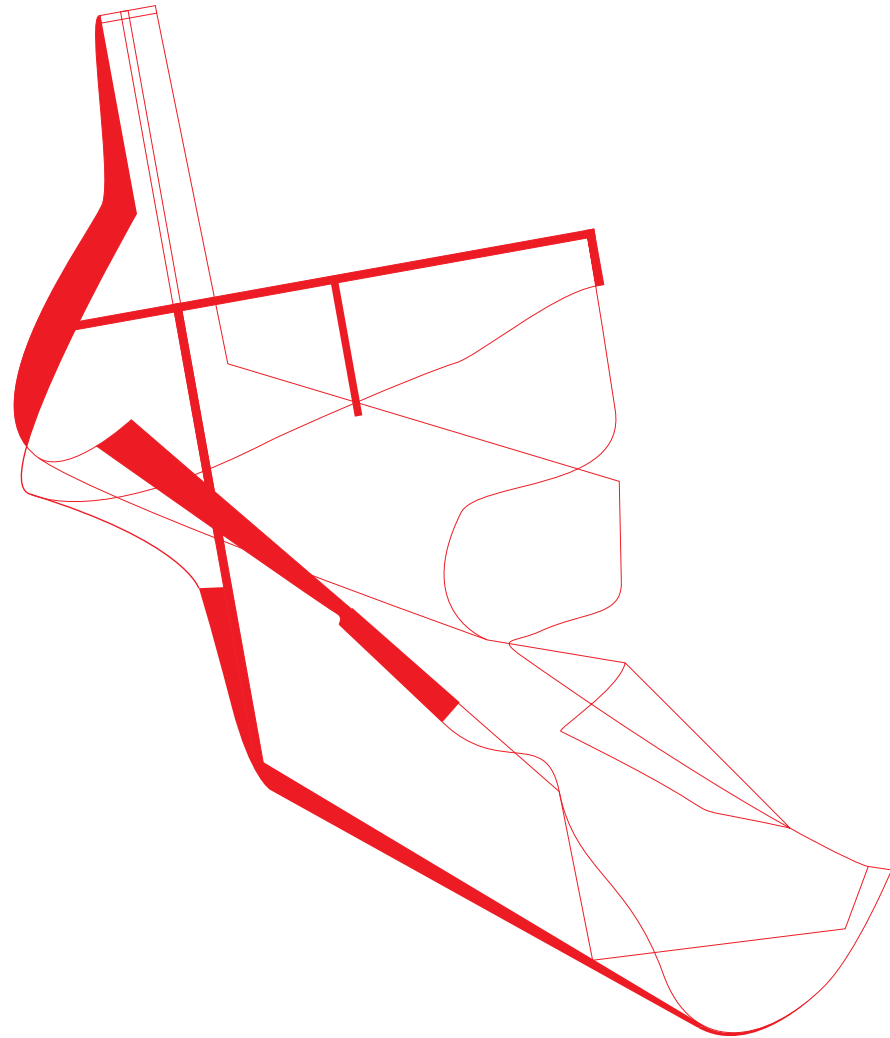

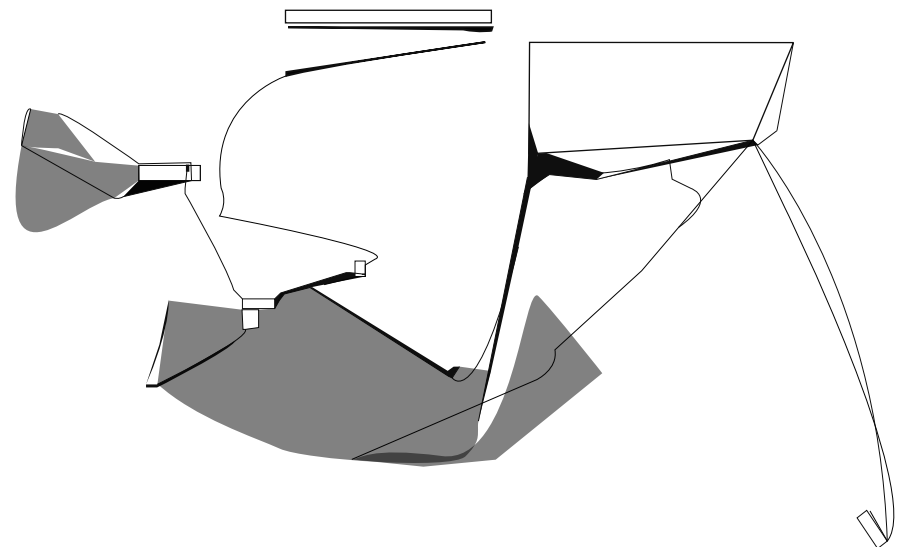
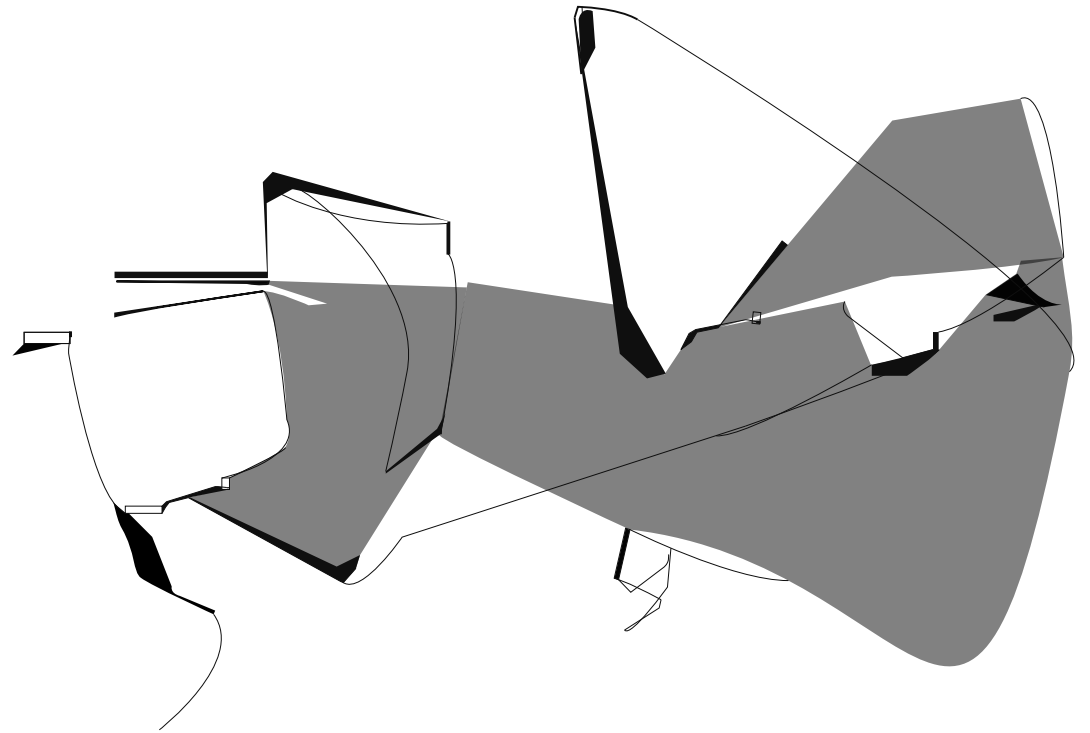

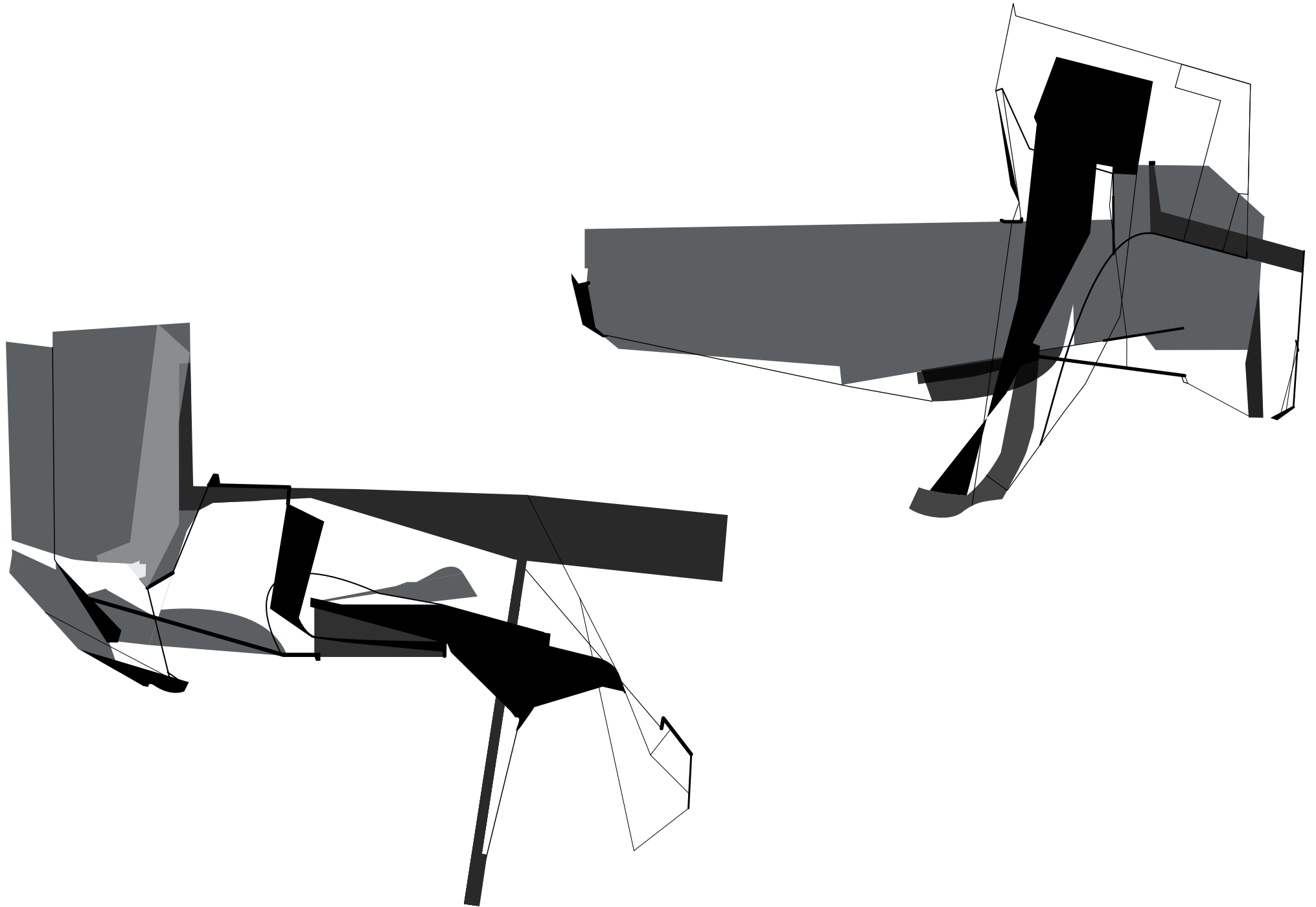

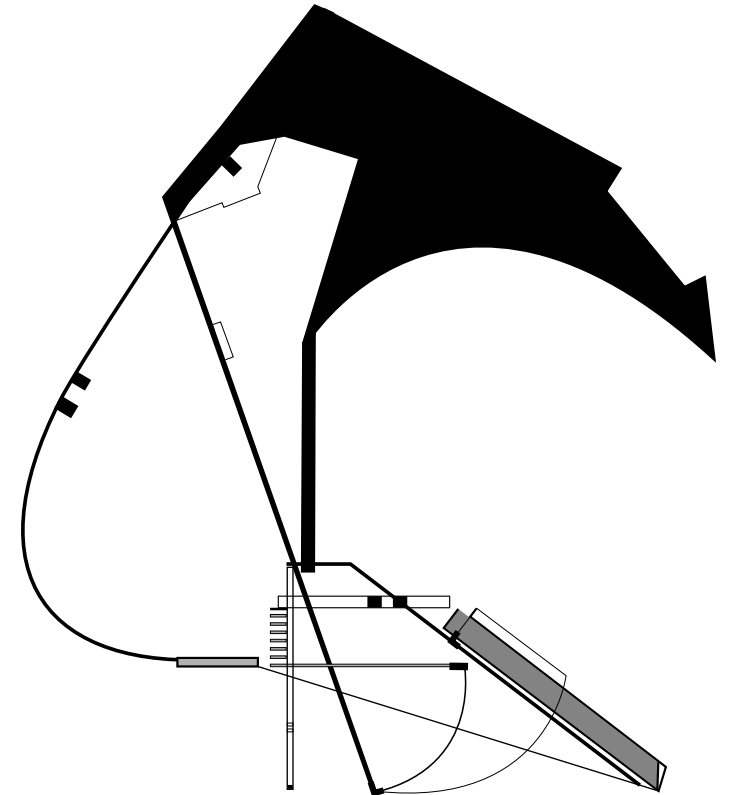
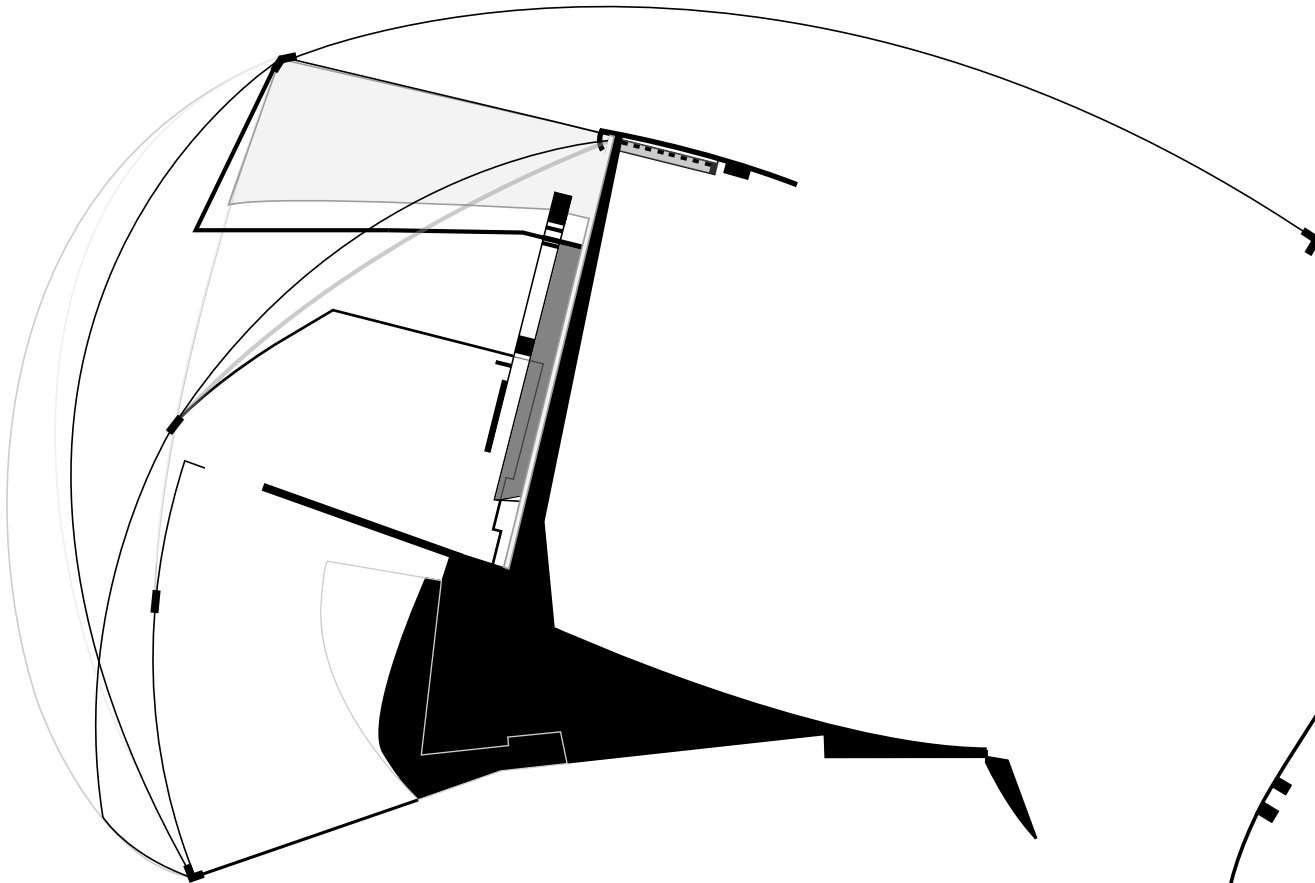

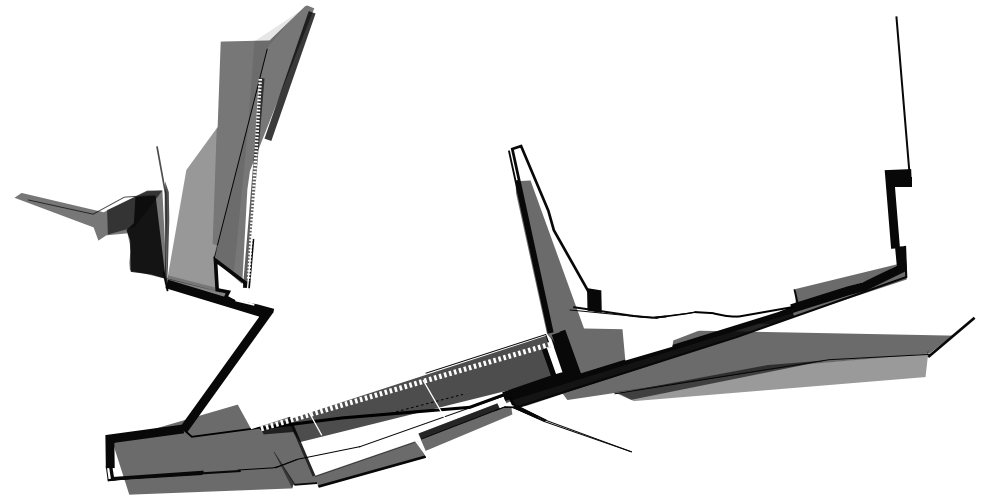
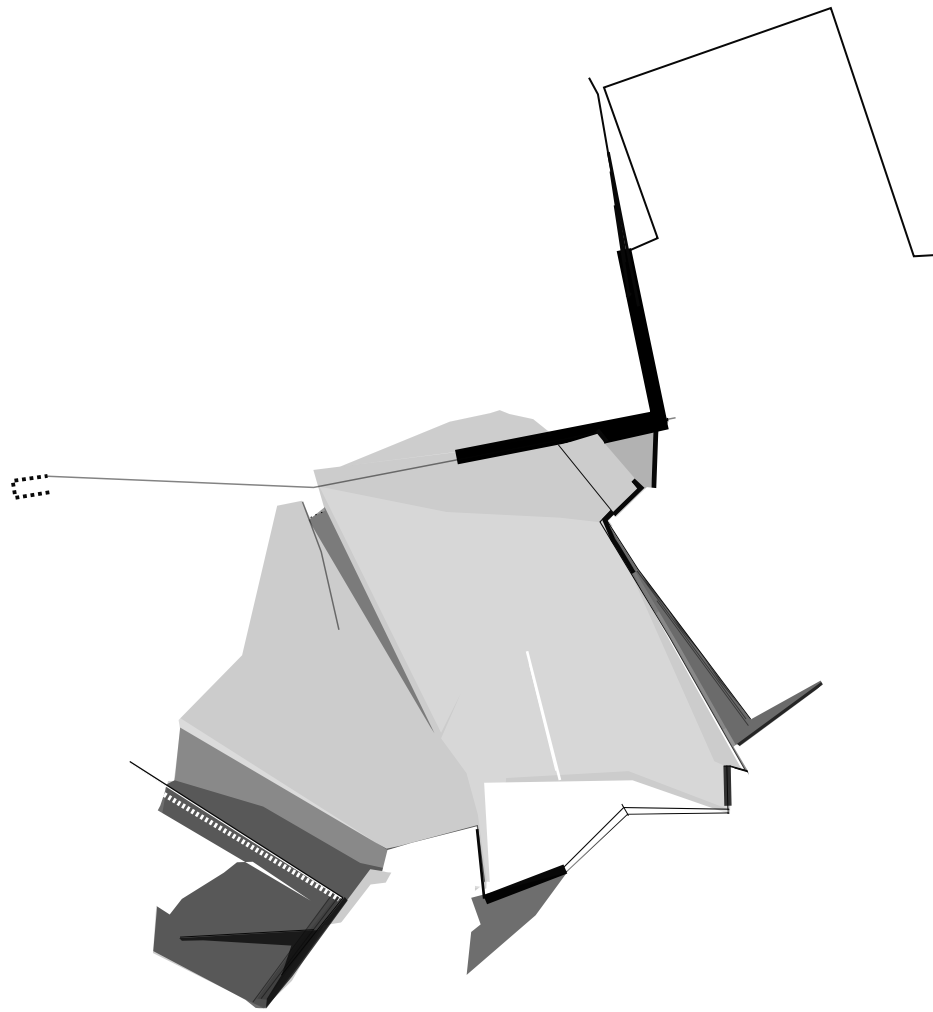

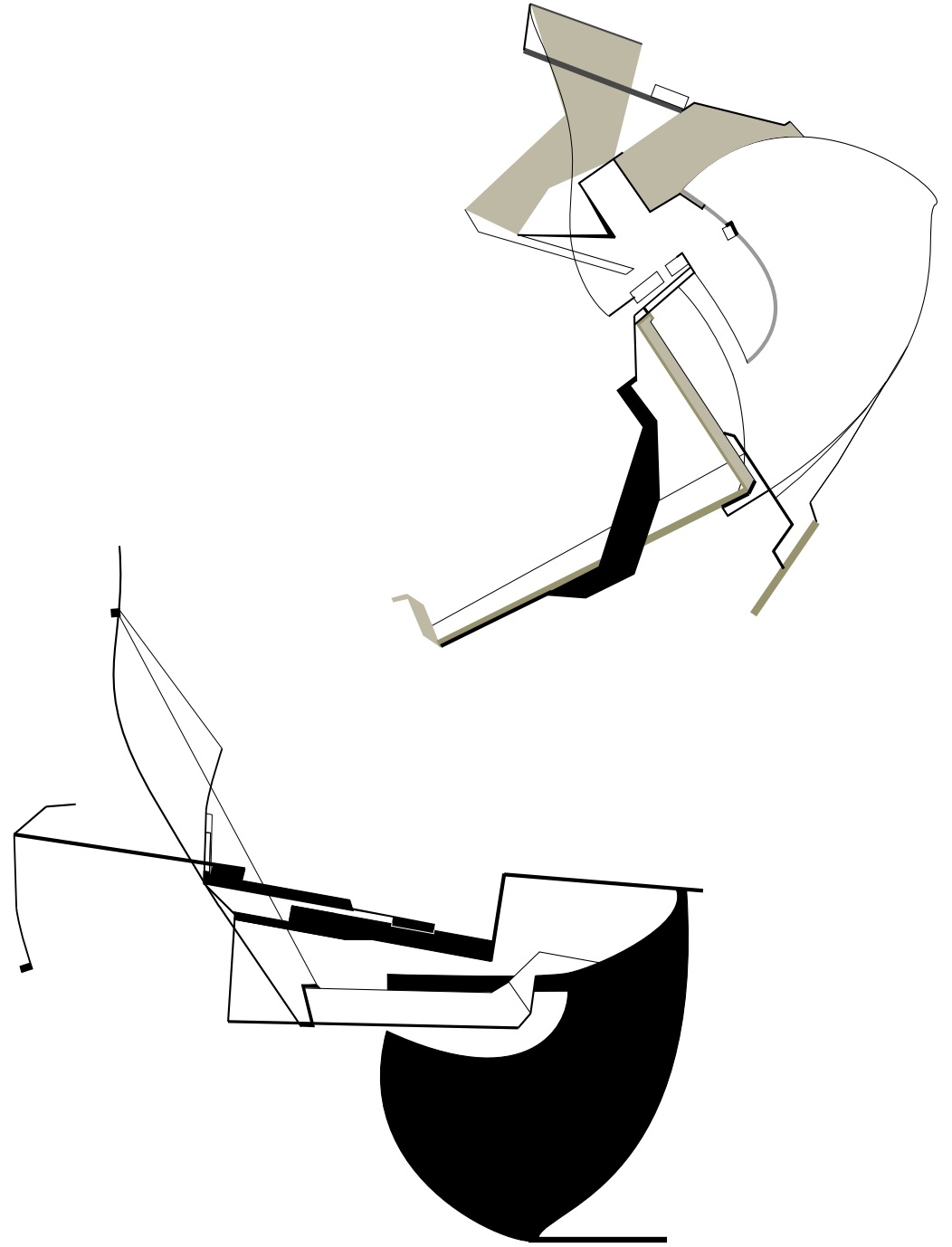

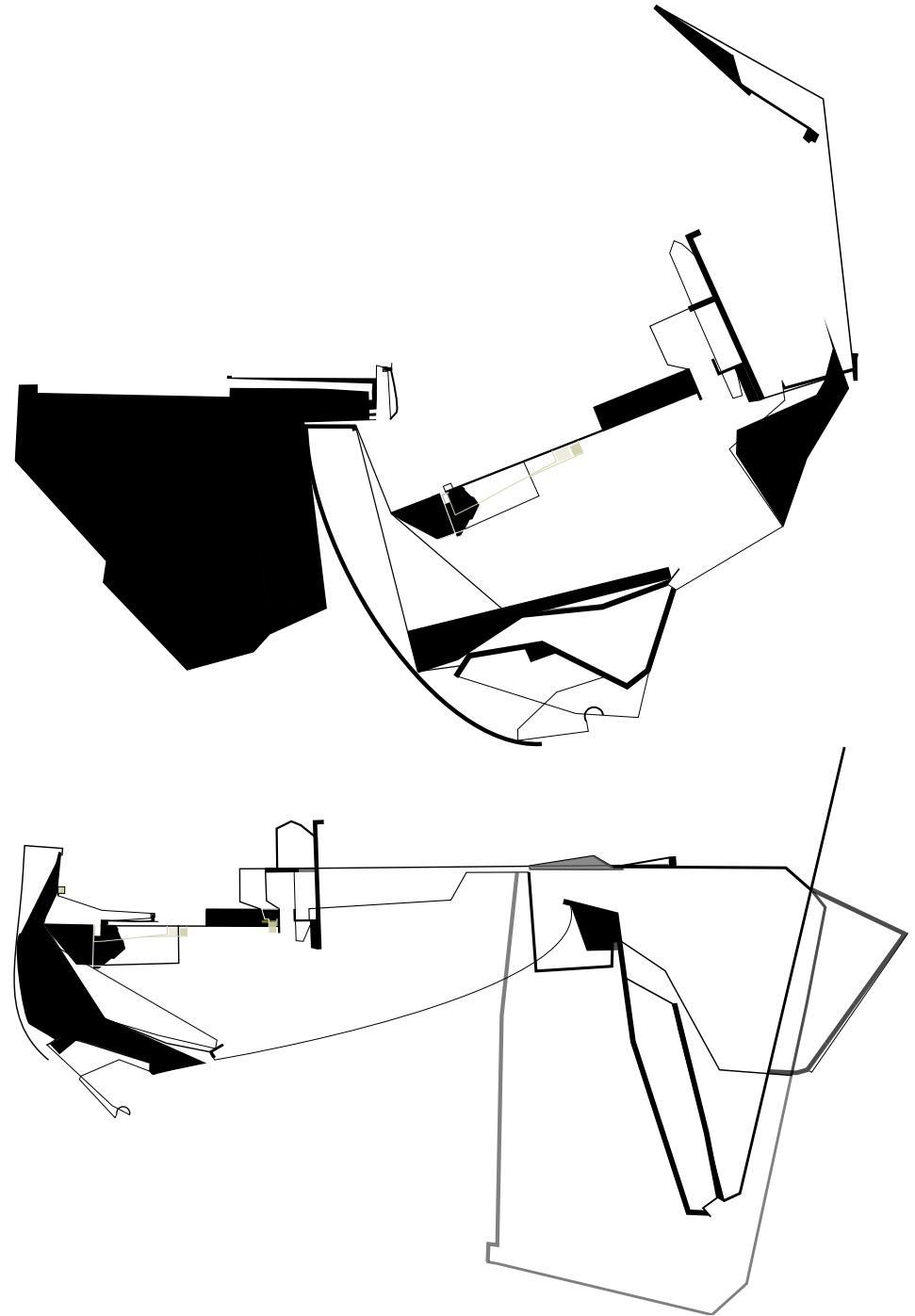

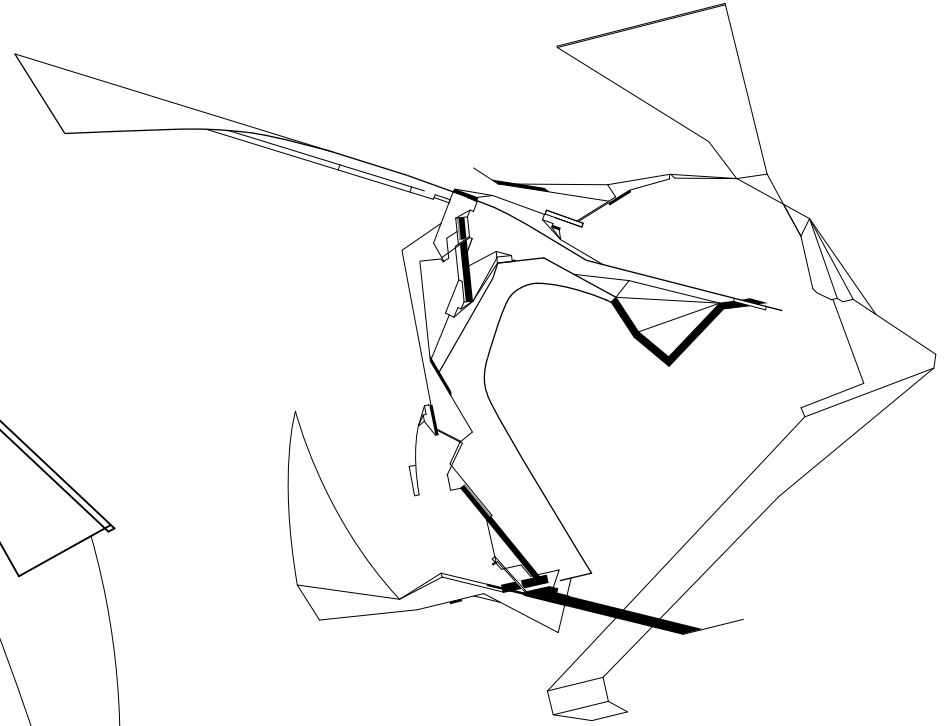
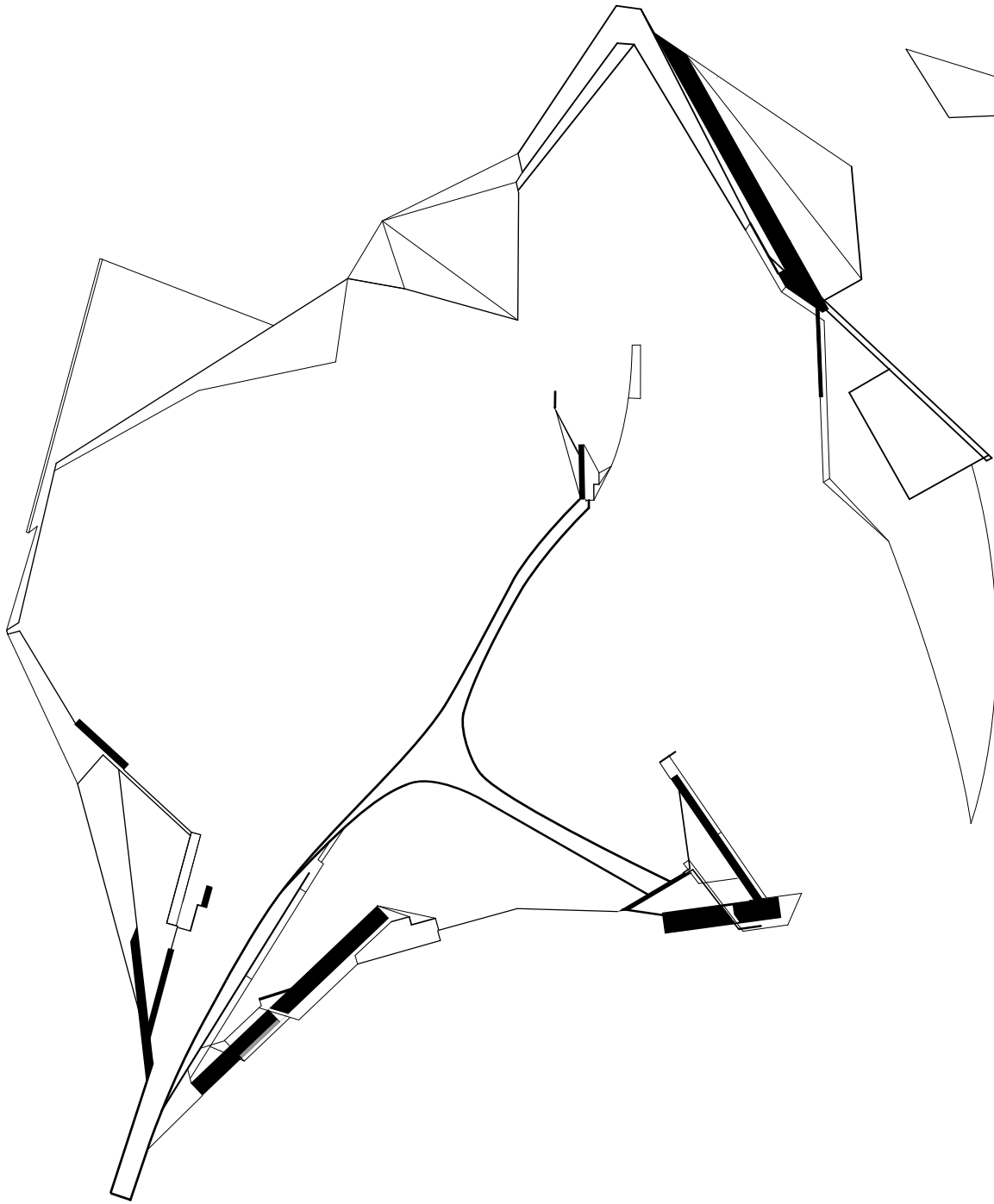

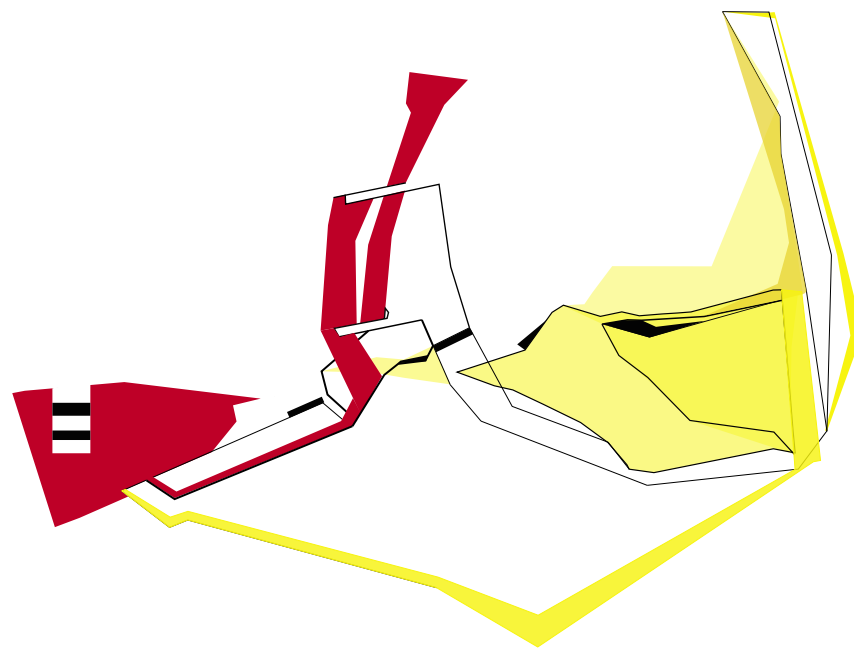
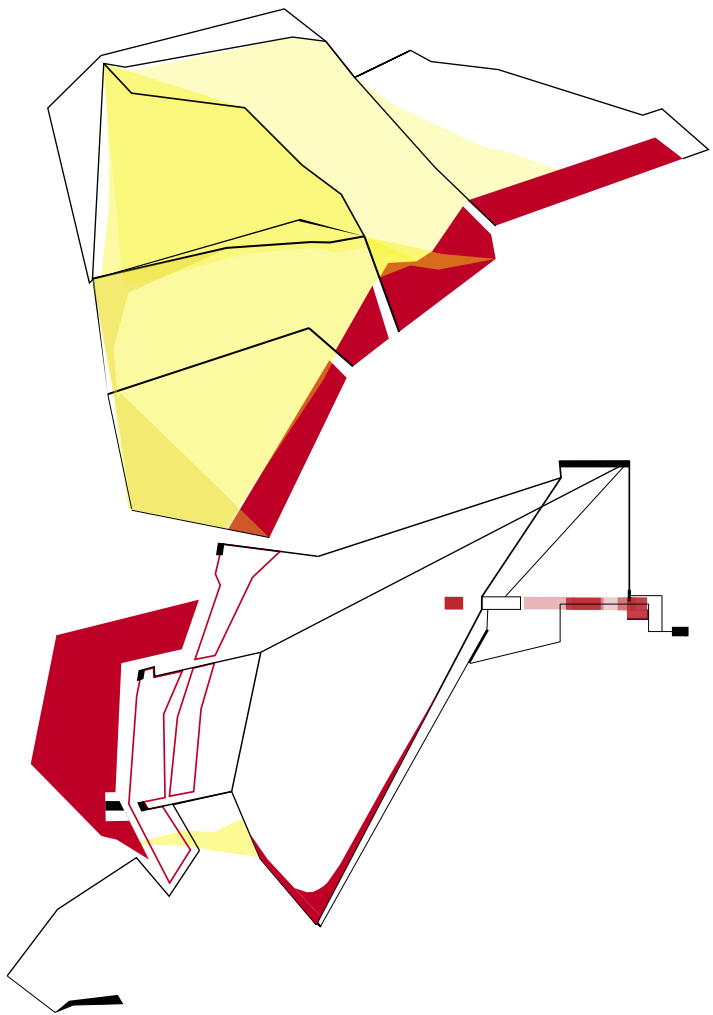

—
—

